

GENERAL DATA

Z Series & DS Series

Fixed speed

Series			Z							
Model			ZS4084S1	ZS6013S1	ZS7516S1	ZS1120S1	ZS1120S2	※ZS7516S3	※ZS1120S3	
Scroll Profile			Involute	Involute	Involute	Involute	Algebraic	Involute	Involute	
Rated Output	W		400	600	750	1,100	1,100	750	1,100	
Displacement	cm ³ /rev.		8.4	12.5	15.9	20.1	20.1	15.9	20.1	
Power supply	Phase	φ	1	1	1	1	1	1	1	
	Voltage	V	220-240	220-240	220-240	220-240	220-240	220-230	220-230	
Oil	Frequency	Hz	50	50	50	50	50	50	50	
			POE	POE	POE	POE	POE	POE	POE	
Oil Charge	cm ³		550	550	550	650	650	550	650	
Weight	kg		12.4	12.6	12.9	13.6	13.6	12.9	13.6	
	lbs		27.3	27.8	28.4	30.0	30.0	28.4	30.0	
Overload Protection			Internal protector	Internal protector	Internal protector	Internal protector	Internal protector	Internal protector	Internal protector	
Motor Type			CSR	CSR	CSR	CSR	CSR	CSR	CSR	
Test Condition			EN12900 MT	EN12900 MT	EN12900 MT	EN12900 MT	EN12900 MT	EN12900 LT	EN12900 MT	
	N(Hz)		50	50	50	50	50	50	50	
Performance	R404A	Cooling Capacity	W	830	1,235	1,570	1,985	1,985	770	-
			BTU/h	2,832	4,214	5,358	6,774	6,774	2,628	-
	R449A	Cooling Capacity	W	800	1,195	1,520	1,920	-	-	-
			BTU/h	2,730	4,078	5,187	6,552	-	-	-
	R1270	Cooling Capacity	W	-	-	1,635	2,065	-	-	-
			BTU/h	-	-	5,579	7,047	-	-	-
	R290	Cooling Capacity	W	-	-	-	-	-	-	1,355
			BTU/h	-	-	-	-	-	-	4,624
Certificate			CE	CE	CE CCC	CE CCC	CE CCC	CE	CE	

Series			Z												
Model			ZS4084P1	ZS6013P1	ZS6013X1	ZS7516X1	ZS1120X1	※ZS6013X3	※ZS7516X3	※ZS1120X3					
Scroll Profile			Involute	Involute	Involute	Involute	Involute	Involute	Involute	Involute	Involute	Involute	Involute	Involute	
Rated Output	W		400	600	600	750	1,100	600	750	1,100					
Displacement	cm ³ /rev.		8.4	12.5	12.5	15.9	20.1	12.5	15.9	20.1					
Power supply	Phase	φ	1	1	1	1	1	1	1	1					
	Voltage	V	115	115	208-230	208-230	208-230	208-230	208-230	208-230					
Oil	Frequency	Hz	60	60	60	60	60	60	60	60					
			POE	POE	POE	POE	POE	POE	POE	POE					
Oil Charge	cm ³		550	550	550	550	650	550	550	650					
Weight	kg		12.4	12.4	12.6	12.7	13.6	12.6	12.7	13.6					
	lbs		27.3	27.3	27.8	28.0	30.0	27.8	28.0	30.0					
Overload Protection			Internal protector	Internal protector	Internal protector	Internal protector	Internal protector	Internal protector	Internal protector	Internal protector					
Motor Type			CSR	CSR	CSR	CSR	CSR	CSR	CSR	CSR					
Test Condition			EN12900; ARI540	EN12900; ARI540	EN12900; ARI540	EN12900; ARI540	EN12900; ARI540	EN12900; ARI540	EN12900; ARI540	EN12900; ARI540	EN12900; ARI540	EN12900; ARI540	EN12900; ARI540	EN12900; ARI540	
	N(Hz)		60	60	60	60	60	60	60	60	60	60	60	60	
Performance	R404A	Cooling Capacity	W	990	1,040	1,475	1,550	1,475	1,550	1,875	1,970	2,370	2,490	-	-
			BTU/h	3,378	3,549	5,033	5,289	5,033	5,289	6,398	6,723	8,088	8,497	-	-
	R449A	Cooling Capacity	W	-	-	-	-	1,420	1,535	1,810	1,955	2,285	2,470	-	-
			BTU/h	-	-	-	-	4,846	5,238	6,177	6,671	7,798	8,429	-	-
	R448A	Cooling Capacity	W	-	-	-	-	1,420	1,535	1,810	1,955	2,285	2,470	-	-
			BTU/h	-	-	-	-	4,846	5,238	6,177	6,671	7,798	8,429	-	-
	R290	Cooling Capacity	W	-	-	-	-	-	-	-	-	-	-	1,270	1,331
			BTU/h	-	-	-	-	-	-	-	-	-	-	4,334	4,542
Certificate			UL	UL	UL	UL	UL	UL	UL	UL	UL	UL	UL	UL	

Test Condition

	Te(°C)	T(°C)	SC(deg)	Ts(°C)
EN12900 MT	-10.0	45.0	0	20.0
EN12900 LT	-35.0	40.0	0	20.0
ARI540 MT	-6.7	48.9	0	18.3
ARI540 LT	-31.7	40.6	0	18.3

※ Under development

Note:

Algebraic: Type of scroll wrap improved performance at low temperature condition.

Series		DS												
Model		DS1836S1			DS1529S1			DS1529X1			DS1834X1			
Scroll Profile		Involute			Algebraic			Algebraic			Algebraic			
Rated Output		W 1,800			1,500			1,500			1,800			
Displacement		cm ³ /rev. 35.7			29.1			29.1			34.0			
Power supply		Phase φ 1			1			1			1			
		Voltage V 220-240			220-240			208-230			208-230			
		Frequency Hz 50			50			60			60			
Oil		POE			POE			POE			POE			
Oil Charge		cm ³ 850			850			850			850			
Weight		kg 22.9			22.6			22.7			22.6			
		lbs 50.5			49.8			50.0			49.8			
Overload Protection		Internal protector			Internal protector			Internal protector			Internal protector			
Motor Type		CSR			CSR			CSR			CSR			
Test Condition				EN12900 MT	EN12900 MT	EN12900 LT	EN12900 MT	ARI540 MT	EN12900 LT	ARI540 LT	EN12900 MT	ARI540 LT	EN12900 LT	
		N(Hz)		50	50	50	60	60	60	60	60	60	60	
Performance	R404A	Cooling Capacity	W	3,525	2,875	1,110	3,430	3,605	1,310	1,490	4,210	4,425	1,530	1,740
			BTU/h	12,029	9,811	3,788	11,705	12,302	4,470	5,085	14,367	15,100	5,221	5,938
	R449A	Cooling Capacity	W	3,405	2,775	990	3,310	3,575	1,205	1,395	3,865	4,175	1,410	1,630
			BTU/h	11,620	9,470	3,378	11,295	12,200	4,112	4,760	13,189	14,247	4,812	5,562
	R448A	Cooling Capacity	W	3,405	2,775	990	3,310	3,575	1,205	1,395	3,865	4,175	1,410	1,630
			BTU/h	11,620	9,470	3,378	11,295	12,200	4,112	4,760	13,189	14,247	4,812	5,562
R1270	Cooling Capacity	W	3,670	2,995	1,250	-	-	-	-	-	-	-	-	
		BTU/h	12,524	10,220	4,266	-	-	-	-	-	-	-	-	
Certificate		CE CCC			CE CCC			UL			UL			

Series		DS										
Model		DS1529V1				DS1834V1				DS2244V1		
Scroll Profile		Algebraic				Algebraic				Algebraic		
Rated Output		W 1,500				1,800				2,200		
Displacement		cm ³ /rev. 29.1				34.0				44.0		
Power supply		Phase φ 3				3				3		
		Voltage V 380-415				380-415				380-415		
		Frequency Hz 50				50				50		
Oil		POE				POE				POE		
Oil Charge		cm ³ 850				850				850		
Weight		kg 21.8				21.7				23.7		
		lbs 48.1				47.8				52.2		
Overload Protection		Internal protector				Internal protector				Internal protector		
Motor Type		IR				IR				IR		
Test Condition				EN12900 MT	EN12900 LT	EN12900 MT	EN12900 LT	EN12900 MT	EN12900 LT	EN12900 MT	EN12900 LT	
		N(Hz)		50	50	50	50	50	50	50		
Performance	R404A	Cooling Capacity	W	2,875	1,110	3,360	1,300	4,345	1,680			
			BTU/h	9,811	3,788	11,466	4,436	14,827	5,733			
	R410A	Cooling Capacity	W	-	-	-	-	-	-	-		
Certificate		CE				CE				CE		



SPECIFICATION

Z Series



DIMENSIONS

	mm	
	A	B
ZS4084	311	357
ZS6013	316	362
ZS1120	321	367
ZS7798/ZS098	302	348
ZS1216/ZS159	307	353
ZS1520/ZS201	302	348
ZD125XC1	307	353
ZD201XC1	307	353

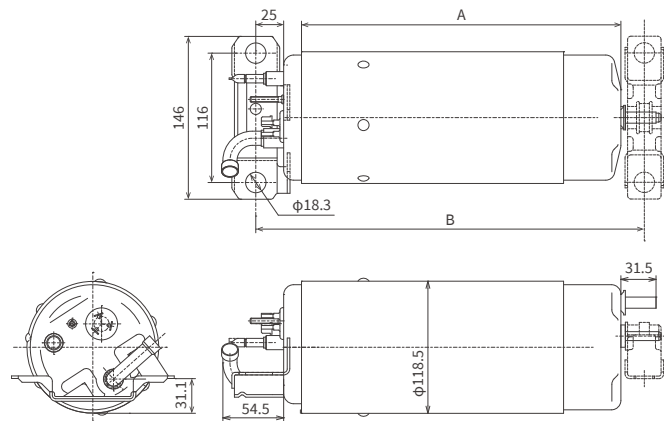

WORKING RANGE

R404A
ZS4084S1/ZS4084P1/ZS6013S1/ZS6013P1/ZS6013X1/ZS7516S1/ZS7516X1

R449A
ZS4084S1/ZS6013S1/ZS6013X1/ZS7516S1/ZS7516X1

R448A
ZS6013X1/ZS7516X1

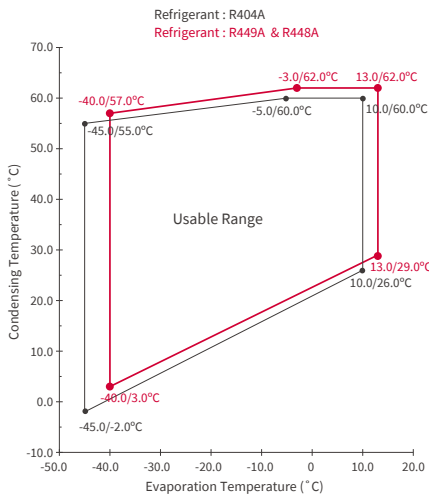

R1270
ZS7516S3

R290
ZS6013X3/ZS7516S3/ZS7516X3

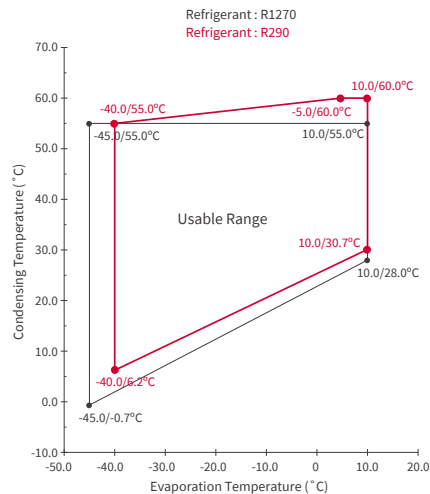

WORKING RANGE

R404A

ZS1120S1/ZS1120S2/ZS1120X1

R449A R448A

ZS1120S1/ZS1120X1 ZS1120X1

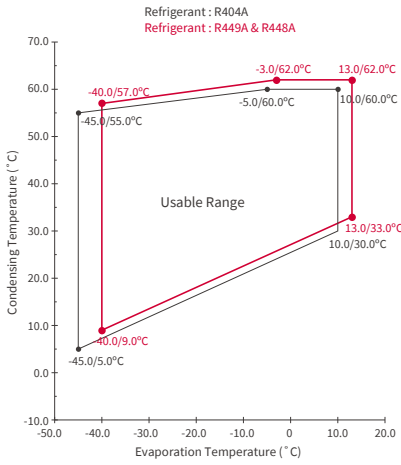

R1270

ZS1120S3

R290

ZS1120S3/ZS1120X3

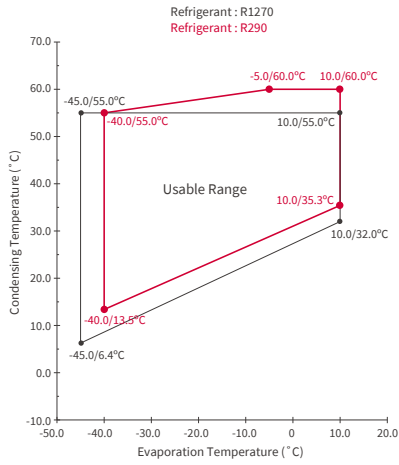

R404A

ZS7798D1/ZS1216D1/ZS1520D1

R449A, R448A

ZS7798D1/ZS1216D1/ZS1520D1

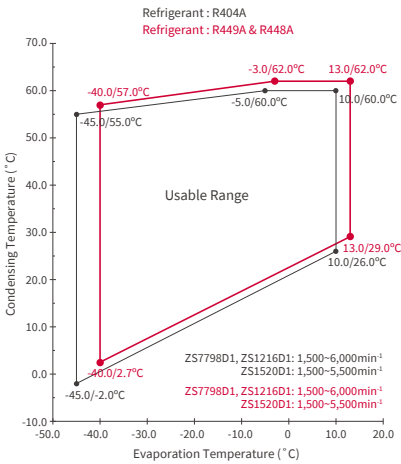

R1270

ZS098XJ1/ZS159XJ1/ZS201XJ1

R290

ZS098XJ1/ZS159XJ1/ZS201XJ1

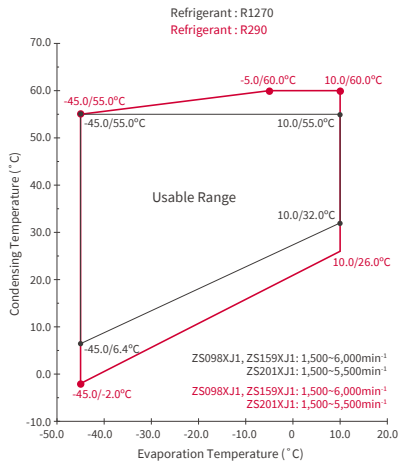

R410A

ZD125XC1

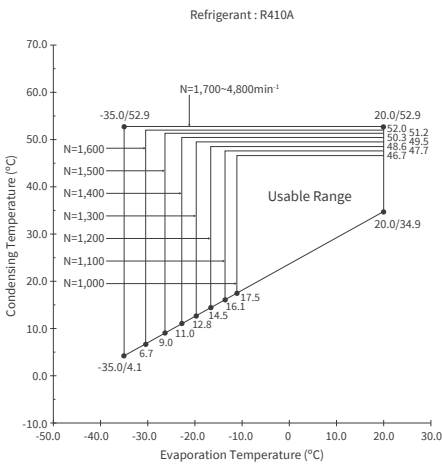

R410A

ZD201XC

