

# SmartCella

Electronic controller

# CAREL



## **(ENG)** User manual

**→ LEGGI E CONSERVA QUESTE ISTRUZIONI ←**  
**→ READ AND SAVE THESE INSTRUCTIONS ←**

  **NO POWER & SIGNAL CABLES TOGETHER**

**READ CAREFULLY IN THE TEXT!**

High Efficiency Solutions

# 1. INTRODUCTION

SmartCella comprises a series of microprocessor-based parametric electronic controllers, with LED display, designed to control single-phase cold rooms.

This controller is especially suitable for applications requiring high load switching power, functions and control with direct access from the keypad, high IP ingress protection and compact dimensions. In terms of reliability, all the controllers are fitted with an electronic device (watchdog) that prevents the microprocessor from losing control, even with high levels of electromagnetic disturbance.

SmartCella is made using the most advanced SMD technology, and electrical testing of all the components fitted guarantees high quality standards.

In summary:

- up to 4 relay outputs on the more complete models: compressor, fan, defrost, AUX1;
- wall mounting;
- buttons flush with the front panel, to ensure high ingress protection (IP65) and safety during operation and cleaning;
- bright 3 digit display, with decimal point and icons to denote operating status;
- immunity to brief power interruptions: if the controller detects that voltage drops below a certain threshold, the display is temporarily switched off and the controller continues working normally;
- keypad with 4 buttons
- defrosts can be activated from the keypad, digital input, supervisor;
- management of various types of defrost, on one or two evaporators: natural (stopping the compressor), heater, hot gas;
- advanced defrost functions;
- automatic recognition of the network protocol: Carel or Modbus®;
- parameter selection simplified by different icons according to the category;
- temperature control with virtual control probe and set point variation at night;
- digital inputs to activate alarms, enable or activate defrosts, door / curtain switch, auxiliary output, on/off , etc.;
- control of 1 compressor with two steps, or two compressors, including rotation;
- keypad protection: the functions of the individual buttons can be disabled to prevent unwanted tampering;
- management of the light in the cabinet/cold room and the curtain on the cabinet;
- VPM program (Visual Parameter Manager), running on a personal computer, used to update the parameters and test the controller;
- alarm signal buzzer;
- HACCP functions: temperature monitoring and recording in the event of high temperature alarms during operation and after blackouts;
- RS485 serial network connection to remote supervisor and telemaintenance systems.

The models differ in terms of:

- the type of power supply: transformer 230V~, switching 115/230 V~;
- the number of relay outputs;

Available accessories include:

- serial interface card (P/N IROPZ48500) for connection to the RS485 network;
- programming key (P/N IROPZKEY\*\*) for reading (upload) and writing (download) the control parameters;
- display interface (P/N IROPZDSP00) for remote display connection.

## 1.1 Main features

SmartCella is designed to offer maximum installation flexibility. In addition to the control probe, further four probes can be configured, as product probe (display only), condenser, frost protection and defrost probe. Using the advanced defrost functions, if the conditions are right, subsequent defrosts can be postponed or skipped. The digital outputs (relays) can control the solenoid valve or compressor, a second compressor, the evaporator or condenser fans, defrosts, lights and alarms. The digital inputs can be used for the door switch and light management, the curtain switch to change over to night-time operation, to enable and start defrosts, to switch the controller on/off and to activate of the auxiliary output. Finally, the controller can also be used as simple ON/OFF thermostat, for heating applications.

Example of a cold room.

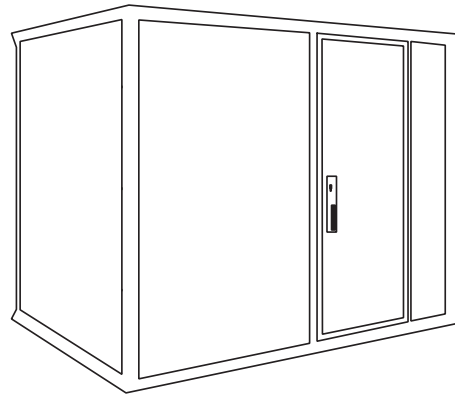

Fig. 1.a

Available P/Ns

Code	Description
WE00S1EN00	1 relay: compressor (16A), 230vac, 180° screw terminals
WE00C2HN00	4 relays: compressor (2Hp) , defrost (16A), fan (8A), AUX (8A), 115/230vac, 180° screw terminals

Tab. 1.a

## 1.2 Accessories

### IROPZKEY00/A0 programming key

The IROPZKEY00 and IROPZKEY00A0 (powered) programming keys can be used with SmartCella. Visual Parameter Manager (VPM) allows up to 7 different configurations (sets) of parameters to be loaded onto the controller (the controller operating parameters plus 6 sets of customizable parameters). The read/write operations are carried out with the controller off.

IROPZKEY00



Fig. 1.b

IROPZKEYA0



Fig. 1.c

**Connection cable (P/N PSTCON0\*B0)**

Three-wire cable to connect the controller to the tLAN interface card (P/N IROPZDSP00). Available in different lengths: 1.5; 3; 5 m.



Fig. 1.d

**Remote display (P/N IREVGXD000)**

The remote display (for model with switching power supply) can be used to display one of the system variables.



Fig. 1.e

**RS485 serial interface (P/N IROPZ48500 and IROPZ485S0)**

Plugged directly into the programming key connector, this provides connection to the PlantVisor supervisory system. The accessory has been designed as a plug-in addition to the controller and consequently can be installed following installation if needed. Model IROPZ485S0 features a microprocessor and can automatically recognize the TxRx+ and TxRx signals (reverse connection).



Fig. 1.f

**RS485 serial board (P/N IROPZSER30)**

The IROPZSER30 board is used to connect SmartCella via the RS485 network serial to supervisory system (using the removable terminal supplied), as well as direct connection of the instrument to the repeater display using a PSTCON\*\*B00 cable.

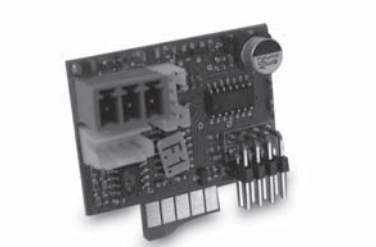

Fig. 1.g

**VPM programming tool (Visual Parameter Manager)**

The program can be downloaded from <http://ksa.carel.com>. The tool runs on a computer and is used to set up the controller, change the parameter settings and update the firmware. The USB/I2C converter P/N IROPZPRG00 is required.



Fig. 1.h

**USB/I2C converter and cable (P/N IROPZPRG00)**

Converter used to connect a personal computer to an IROPZKEY00/A0 programming key, and consequently use the VPM program (Visual Parameter Manager) to read, set and write the parameters. The programming key can then be used to program the controllers or read the controller parameters, and for example copy a configuration from one controller to the others.



Fig. 1.i

## 2. INSTALLATION

### 2.1 Dimensions (mm)

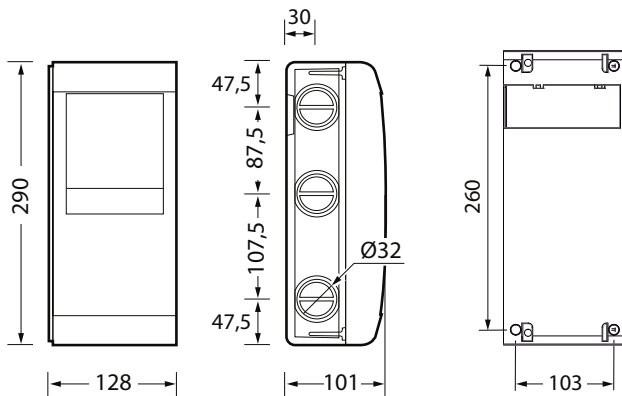
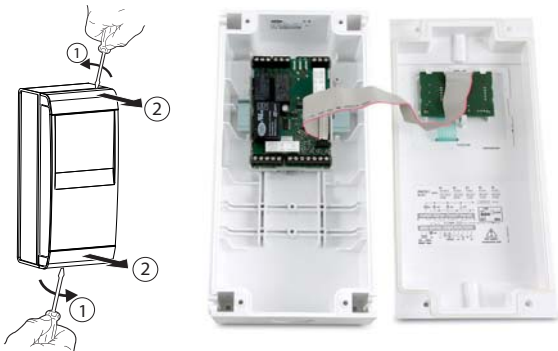

Fig. 2.a

### 2.2 Wall mounting



1. Remove the faceplates (1 and 2) and unscrew the screws to open the control



2. Release flat connector to remove frontal panel
3. **a.** Mounting with DIN rail: Fix the DIN rail on the wall and insert the controller. Mark the positions of the 2 bottom holes corresponding to drilling template and extract the control. Drill the 2 holes (Ø 4,5 mm), insert again the control and fix the 2 bottom screws
3. **b.** Mounting without DIN rail: Mark the positions of the 4 holes corresponding to drilling template, drill the holes (Ø 4,5 mm) and fix control to wall with 4 screws
4. Complete the wiring of the cables and the necessary components
5. Insert flat connector and frontal panel box to electronic board. Close the front panel fixing the 4 supplied screws corresponding to the holes

### 2.3 Wiring diagram

WE00SxExxx

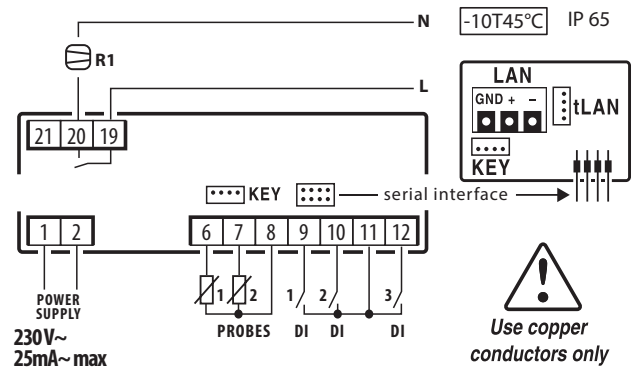

Fig. 2.b

WE00CxHxxx

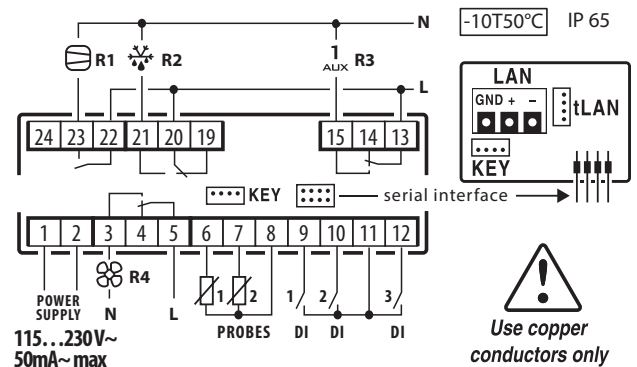

Fig. 2.c

### 2.4 Installation

To install the controller, proceed as follows, with reference to the wiring diagrams shown in the previous paragraphs:

1. connect the probes and power supply: the probes can be installed up to a maximum distance of 10 m from the controller, using shielded cables with a minimum cross-section of 1 mm<sup>2</sup>. To improve immunity to disturbance, use probes with shielded cables (connect only one end of the shield to the earth on the electrical panel);
2. program the controller: as shown in the chapters "Commissioning" and "User interface";
3. connect the actuators: the actuators should only be connected after having programmed the controller. Carefully check the maximum relay capacities, as indicated in the "technical specifications";
4. serial network connection: all controllers are fitted with a serial connector for connection to the supervisor network via the serial interface (IROPZ485\*0 or serial board IROPZSER30). The secondary of the transformers that supply the controllers must not be earthed. If connection to a transformer with earthed secondary winding is required, an insulating transformer must be installed in between.

**! Important:** a separate transformer must be used for each controller, - NEVER connect multiple controllers to the same transformer.

**Warnings:** avoid installing the controller in environments with the following characteristics:

- relative humidity greater than 90% non-condensing;
- strong vibrations or knocks;
- exposure to continuous water sprays;
- exposure to aggressive and polluting atmospheric agents (e.g.: sulphur and ammonia gases, saline mist, smoke) which may cause corrosion and/or oxidation;
- strong magnetic and/or radio frequency interference (for example , near transmitting antennae);
- exposure to direct sunlight and the elements in general.

The following warnings must be observed when connecting the controllers:

- incorrect connection of the power supply may seriously damage the controller;
- use cable ends suitable for the corresponding terminals. Loosen each screw and insert the cable ends, then tighten the screws and gently pull the cables to check their tightness. When tightening the screws, do not use automatic screwdrivers, rather adjust tool tightening torque to less than 0.5Nm;
- separate as much as possible (by at least 3 cm) the probe signal and digital input cables from inductive loads and power cables, to avoid any electromagnetic disturbance. Never lay power cables and probe cables in the same cable conduits (including those for the electrical panels). Do not install the probe cables in the immediate vicinity of power devices (contactors, circuit breakers or the like). Reduce the length of the sensor cables as much as possible, and avoid spirals around power devices;
- only use IP67 guaranteed probes as end defrost probes; place the probes with the vertical bulb upwards, so as to facilitate drainage of any condensate. Remember that thermistor temperature probes (NTC) have no polarity, so the order the ends are connected in is not important.

**Cleaning the controller**

When cleaning the controller do not use ethanol, hydrocarbons (petrol), ammonia and by-products. Use neutral detergents and water.

**2.5 Programming key IROPZKEY00/A0**

The programming key can load up to 7 different parameter configurations onto the controller (the controller operating parameters plus 6 sets of customisable default parameters). The keys are plugged into the connector (4 pin AMP) available on the controllers. All the operations can be performed with the controller off.

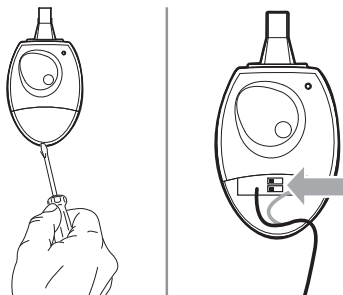
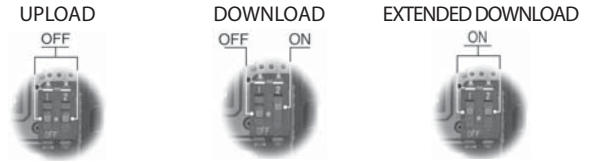

Fig. 2.d

The functions are selected by setting the two dipswitches, accessible by removing the battery cover.



- load the parameters from a controller onto the key (UPLOAD);
- copy from the key to a controller (DOWNLOAD);
- extended copy from the key to a controller (EXTENDED DOWNLOAD).

**Important:** The parameters can only be copied between controllers with the same part number. The UPLOAD operation can, however, always be performed.

**Copying and downloading the parameters**

The following operations are used for the UPLOAD and/or DOWNLOAD functions, simply by changing the settings of the dipswitches on the key:

1. open the rear cover on the key and position the 2 dipswitches according to the desired operation;
2. close the rear cover on the key and plug the key into the connector on the controller;
3. press the button and check the LED: red for a few seconds, then green, indicates that the operation was completed correctly. Other signals or the flashing of the LED indicates that problems have occurred: see the table below;
4. at the end of the operation, release the button, after a few seconds the LED goes off;
5. remove the key from the controller.

LED signal	Error	Meaning and solution
Red LED flashing	Batteries discharged at start copy	The batteries are discharged, the copy operation cannot be performed. <u>Replace the batteries.</u>
Green LED flashing	Batteries discharged during copy or at end of copy	During the copy operation or at the end of the operation the battery level is low. <u>Replace the batteries and repeat the operation.</u>
Red/green LEDs flashing (orange signal)	Controller not compatible	The parameter set-up cannot be copied as the connected controller model is not compatible. This error only occurs for the DOWNLOAD function; check the controller P/N and run the copy only for <u>compatible models.</u>
Red and green LEDs on	Error in data being copied	Error in the data being copied. The EEPROM on the controller is corrupted, therefore the data cannot be copied to/from the key.
Red LED on steady	Data transfer error	The copy operation was not completed due to a serious error when transferring or copying the data. Repeat the operation, if the problem persists check the key connections.
LEDs off	Batteries disconnected	Check the batteries.

Tab. 2.b

**Note:** the DOWNLOAD operation (normal or extended) is possible even if the operating and control parameters are incorrect; in this case, they will be recovered from the key. Be careful when recovering the unit parameters from a key, as these determine the low-level operation of the controller (unit model, type of interface, assignment of logical relay to physical relay, brightness of the display, level of modulation of the relay control signal ...). The unit parameters from the original model must therefore be restored to ensure correct operation of the controller.

## 2.6 Remote display connection

To connect the remote display, use the dedicated cable (P/N PSTCON0\*B0) and serial card (P/N IROPZSER30). See the following diagram.

Also set a value >0 for parameter /tE, to display the reading on the remote display.

Par.	Description	Def	Min	Max	UOM
/tE	Reading on remote display	0	6	6	-
0	Not fitted	4	Probe 3		
1	Virtual probe	5	Probe 4		
2	Probe 1	6	Reserved		
3	Probe 2				

Tab. 2.a

## 2.7 Network connection

### Warnings:

- As serial converter, both IROPZSER30 and IROPZ485x0 can be used;
- the RS485 converter is sensitive to electrostatic discharges and therefore must be handled with extreme care;
- check the documents on the serial interface for connection instructions, so as to avoid damaging the controller;
- fasten the converter properly so as to prevent disconnection;
- complete the wiring without power connected;
- keep the serial interface cables separate from the power cables (relay outputs and power supply).

The RS485 converter is used to connect SmartCella to the supervisor network for the complete management and monitoring of the connected controllers. The system allows a maximum of 207 units, with a maximum length of 1000 m. Connection requires the standard accessories (RS485-USB converter, CAREL P/N CVSTDUMORO) and a 120 Ω terminating resistor to be installed on the terminals of the last connected controller. Connect the RS485 converter to the controllers and make the connections as shown in the figure. To assign the serial address, see parameter H0. See the instruction sheets on the converters for further information.

**Note:** SmartCella can communicate with both Carel and Modbus protocols with auto-recognition

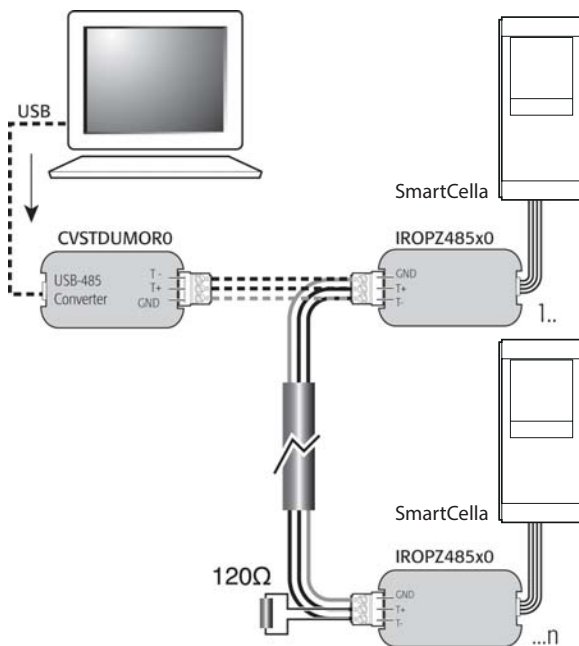









Fig. 2.e

### 3. USER INTERFACE

The front panel contains the display and the keypad, made up of 4 buttons that, when pressed alone or combined with other buttons, are used to program the controller. The optional remote display is used to display the temperature measured by a second probe.





#### 3.1 Display

The user terminal display shows temperature in range -50 to +150°C. The temperature is displayed with resolution to the tenths between -19.9 and + 19.9 °C. In the event of alarms, the value of the probe is displayed alternating with the codes of the active alarms. During programming, the terminal shows the codes and values of the parameters. The remote display IREVXGD000 shows the temperature with resolution to the tenths between -9.9°C and 19.9°C.

Icon	Function	Normal operation			Start-up	Notes
		ON	OFF	Flashing		
	Compressor	On	Off	Awaiting activation		Flashes when activation is delayed or inhibited by protection times
	Fan	On	Off	Awaiting activation		Flashes when activation is delayed by protection times or other procedures in progress
	Defrost	Active	-	Awaiting		Flashes when activation is delayed by protection times or other procedures in progress
	AUX output	AUX output 1 or 2 active	-	Anti-sweat heater function active		
	Alarm	On if delayed alarm from digital input	-	Alarms during normal operation (e.g. high/low temperature alarm) or in the event of malfunctions (on together with the spanner icon)		
	Light	Auxiliary output (1 and/or 2) configured as light active	-	Anti-sweat heater function active		
	Service			Malfunctions, e.g. EEPROM errors or faulty probes		
	Continuous cycle	Continuous cycle function active	-	Function called		Flashes when activation is delayed or inhibited by protection times

Tab. 3.a

#### 3.2 Keypad

Button	Normal function		Start-up
	Pressing the button alone	Pressing together with other buttons	
 PRG/MUTE	if pressed for more than 3 s accesses the menu for setting the password to access the type "F" (frequent) parameters or "C" (Configuration) in the event of alarm: silences the audible alarm (buzzer) and disables the alarm relay	PRG+ON-OFF/UP: if pressed together for more than 3 s reset any alarm with manual reset	if pressed for more than 5 s at start-up, starts the default parameter setting
 ON-OFF/UP	if pressed for more than 3 s disables the regulation / if pressed for more than 1 s, enables the regulation during the parameters modification increase the value displayed move towards the next parameter	ON-OFF/UP+AUX/DOWN: if pressed together for more than 3 s enable/disable the continuous cycle operation ON- OFF/UP+ SET/DEF: if pressed together for more than 3 s display the temperature read by the defrost probe no 1 ON-OFF/UP+ PRG/MUTE: if pressed together for more than 3 s reset any alarm with manual reset	
 AUX/DOWN	if pressed for more than 1 s, enables/disables the auxiliary output during the parameters modification decrease the value displayed or move towards the previous parameter	AUX/DOWN + ON-OFF/UP: if pressed together for more than 3 s enable/disable the continuous cycle operation	
 SET/DEF	if pressed for more than 1 s, enables/displays and/or set the set point if pressed for more than 5 s, enables a manual defrost	SET/DEF+ ON-OFF/UP: if pressed together for more than 3 s display the temperature read by the defrost probe no 1	





Tab. 3.b

### 3.3 Programming

The operating parameters can be modified using the front keypad. Access differs depending on the type: set point, frequently-used parameters (F) and configuration parameters (C). The type of parameter is specified in the table of parameters. Access to the configuration parameters is protected by a password for the configuration parameters that prevents unwanted modifications or access by unauthorised persons. The password can be used to access and set all the control parameters.

#### 3.3.1 Setting the set point











How to set the set point (desired temperature value)

Step	Action	Effect	Meaning
1	Press  for 1 second	After 1 second the display will show the current set point	This the currently active control set point
2	Press  or 	The value on the display will increase or decrease	Set the desired value
3	Press 	The controller will show the temp.read by the probes again	The set point is modified and saved

Tab. 3.c

Another way of changing the set point is to set parameter "St" (see the tables below)

#### 3.3.2 Setting type "F" and "C" parameters

Step	Action	Effect	Meaning
1	Press  for 3 seconds	After 3 seconds the display will show the 1st parameter, "0" (Password)	Access to type "F" parameters is direct without password
2	Press  or 	The value on the display will increase or decrease.	Enter the password "22" to access the type "C" parameters or whatever different value for the type "F" parameters.
3	Press 	The display will show "St" (Setpoint)	This is the current value of the Setpoint
4	Press  or 	If the password set is 22 the display will scroll the list of type "C" parameters (CONFIGURATION) otherwise the list of type "F" parameters (FREQUENT)	Set the desired value
5	Press 	The display will show the parameter name	This is the current value of the parameter
6	Press  or 	The value on the display will increase or decrease	Set the desired value
7	Press 	The display will show the parameter name again	IMPORTANT: parameters not yet saved
8	Repeat steps 2, 3, 4 & 5 for all parameters required		
9	Press  for 5 seconds	The controller will display the temperature read by the probes again	IMPORTANT: only now have all the parameters been updated







Tab. 3.d

For both types of access (type "F" and type "C") there is a timeout (no button on the keypad pressed for 1 min), the procedure is ended without saving the parameter.

#### 3.3.3 Parameter categories

- To move from the parameters in one category to another, when displaying the parameter code, press Prg to show the category and UP and DOWN to move from one category to another;
- if no button is pressed for 10s, the display starts flashing, and after 1 minute automatically returns to the standard display;
- to increase the scrolling speed, press and hold the UP/DOWN button for at least 5 seconds;
- all the changes made to the parameters, temporarily stored in the RAM, can be cancelled, by not pressing any button for 60 seconds, thus returning to the standard display.

Parameter categories

Category	Text	Icon	Category	Text	Icon
Probes	Pro		Alarms	ALM	
Control	CtL		Fan	FAn	
Compressor	CMP		Configuration	CnF	
Defrost	dEF				

Tab. 3.e

#### 3.3.4 Setting the default parameters

To set the parameters to the default values:

- Power down the controller;
- Press Prg/mute;
- Power up the controller holding the Prg/mute button, until the message "Std" is shown on the display, after 5 s.

 **Note:** this will cancel any changes made and restore the original values set by the manufacturer, i.e. the default values shown in the parameter table.

#### 3.3.5 Defrost

To activate a defrost, the defrost probe must measure a temperature less than the end defrost temperature (par. dP1).

**ACTIVATION:** Press  for 5 seconds:

After 5 seconds, the display shows the start defrost signal (dFb) for 3 s. The controller enters defrost mode, with the corresponding icon shown on the display, together with the message "dEF" if set accordingly by parameter d6. The defrost relay is also activated.

Par.	Description	Def	Min	Max	UoM
d6	Terminal display during defrost 0 = Temperature alternating with dEF 1 = Display disabled 2 = dEF	1	0	2	-

Tab. 3.f

**DEACTIVATION:** Press  for 5 seconds:

After 5 seconds, the display shows the end defrost signal (dFE). The controller exits defrost mode, returning to the standard display.

### 3.3.6 On/Off

To switch the controller off from the keypad:

- press On-Off for 3 seconds.

The display shows the text Off flashing for 3 seconds, and then on steady. Finally, the text Off alternates with the standard display. Any active output relays are deactivated.

To switch the controller on from the keypad:

- press On-Off for 1 s.

The display shows the text On for 1 s and then returns to the standard display. Any output relays are activated again.

### 3.3.7 Continuous cycle

For the explanation of the continuous cycle function, see chapter 6.

To activate the continuous cycle, the value of parameter cc must be >0.

**ACTIVATION:** Press ON/OFF + AUX for 5 seconds  + 

The message "cc" flashes on the display for 3 seconds, and subsequently, if the conditions are suitable, the controller shows the start continuous cycle message "ccb" and the corresponding icon on the display.

**DEACTIVATION:** Press ON/OFF + AUX for 5 seconds  + 

The message "cc" flashes on the display for 3 seconds, and subsequently the controller shows the end continuous cycle message, "ccE".

### 3.3.8 Display defrost probe

To display the value measured by the defrost probe:

- press Set and UP together for 3 s;
- the code of parameter d/1 is displayed flashing;
- continue holding the buttons until the value measured by the defrost probe is displayed;
- release the buttons;
- the standard display is shown again after 10 s.

### 3.3.9 Auxiliary/light output activation

To activate the auxiliary (H1 = 2) and/or light output (H1 = 3) from the keypad:

- press AUX;
- the message AUX flashes on the display for 1 s;
- press and hold until activating the output and the corresponding icon on the display, which then shows the standard display.

### 3.3.10 Probe calibration

Parameters /c1 to /c4 are used to calibrate the first, second, third and fourth temperature probe respectively. Access the parameters and then set the required values. When pressing Set, after having entered the value, the display does not show the parameter, but rather immediately shows the new value of the probe reading being calibrated. This means the result of the setting can be checked immediately and any adjustments made as a consequence. Finally, press Prg for 5 seconds to save the value of the parameter.

### 3.3.11 Minimum and maximum temperature monitoring

The controller can record the minimum and maximum temperature measured by the control probe over a period of up to 999 hours (more than 41 days).

To enable monitoring:

- enter programming mode as explained in the corresponding paragraph;
- set r5=1;
- select rt;

Press SET/DEF 

This displays how long minimum and maximum temperature monitoring has been active, (if recording has just been enabled, rt=0);

- to restart temperature recording, press AUX for more than 5 s



The message "rES" indicates that the log has been deleted. The controller resets the total hours and restarts monitoring;

- press Set to return to the list of parameters;
- to display the maximum temperature measured by the probe, read the value associated with parameter rH;
- to display the minimum temperature measured by the probe, read the value associated with parameter rL.

 **Note:** after the maximum time of 999 hours, minimum and maximum temperature monitoring continues, while the time interval remains fixed at 999.



 **Important:** the values of parameters rt, rL and rH are saved to the controller's memory every hour. If the controller is not connected to an uninterruptible power supply, a temporary blackout may mean the values of rt, rL and rH measured in the last hour will be lost. When power returns, the controller automatically restarts monitoring from the previously saved values.

## 7. PARAMETER TABLE

Symbol	Code	Parameter	Models	UOM	Type	Min.	Max.	Def.
	Pw	Password	WE00S% and WE00C%	-	C	0	200	22
	/2	Measurement stability	WE00S% and WE00C%	-	C	1	15	4
	/3	Probe display stability	WE00S% and WE00C%	-	C	0	15	0
	/4	Virtual probe composition	WE00S% and WE00C%	-	C	0	100	0
	/5	Temperature unit of measure (0: °C ,1: °F)	WE00S% and WE00C%	flag	C	0	1	0
	/6	Display decimal point with tenths of a degree without tenths of a degree	WE00S% and WE00C%	flag	C	0	1	0
	/tl	Display on user terminal 1: virtual probe 2: probe 1 3: probe 2 4: probe 3 5: probe 4 6: reserved 7: set point	WE00S% and WE00C%	-	C	1	7	1
	/tE	Reading on remote display 0: remote terminal not present 1: virtual probe 2: probe 1 3: probe 2 4: probe 3 5: probe 4 6: reserved	WE00S% and WE00C%	-	C	0	6	0
	/P	Type of probe 0: NTC standard with range -50T90°C 1: NTC enhanced with range -40T150°C 2: PTC standard with range -50T150°C	WE00S% and WE00C%	-	C	0	2	0
	/A2	Configuration of probe 2 (S2)  0: absent 1: product (display only) 2: defrost 3: condenser 4: antifreeze	WE00S% and WE00C%	- -	C C	0 0	4 4	0 2
	/A3	Configurations of probe 3 (S3/DI1) As for /A2	WE00S% and WE00C%	-	C	0	4	0
	/A4	Configurations of probe 4 (S4/DI2) As for /A2	WE00S% and WE00C%	-	C	0	4	0
	/c1	Calibration of probe 1	WE00S% and WE00C%	°C/°F	C	-20	20	0.0
	/c2	Calibration of probe 2	WE00S% and WE00C%	°C/°F	C	-20	20	0.0
	/c3	Calibration of probe 3	WE00S% and WE00C%	°C/°F	C	-20	20	0.0
	/c4	Calibration of probe 4	WE00S% and WE00C%	°C/°F	C	-20	20	0.0
	St	Set Point	WE00S% and WE00C%	°C/°F	F	r1	r2	0.0
	rd	Differential	WE00S% and WE00C%	°C/°F	F	0.1	20	2.0
	rn	Dead band	WE00S% and WE00C%	°C/°F	C	0.0	60	4.0
	rr	Reverse differential	WE00S% and WE00C%	°C/°F	C	0.1	20	2.0
	r1	Minimum set point	WE00S% and WE00C%	°C/°F	C	-50	r2	-50
	r2	Maximum set point	WE00S% and WE00C%	°C/°F	C	r1	200	60
	r3	Operating mode 0: Direct with defrost control (cooling) 1: Direct (cooling) 2: Reverse-cycle (heating)	WE00S% and WE00C%	flag	C	0	2	0
	r4	Automatic night-time set point variation	WE00S% and WE00C%	°C/°F	C	-20	20	3.0
	r5	Enable temperature monitoring 0: disabled, 1: enabled	WE00S% and WE00C%	flag	C	0	1	0
	rt	Duration of current max and min temperature monitoring session	WE00S% and WE00C%	ore	F	0	999	-
	rH	Maximum temperature read	WE00S% and WE00C%	°C/°F	F	-	-	-
rL	Minimum temperature read	WE00S% and WE00C%	°C/°F	F	-	-	-	
	c0	Compressor, fan and AUX start delay at power on	WE00S% and WE00C%	min	C	0	15	0
	c1	Minimum time between successive compressor starts	WE00S% and WE00C%	min	C	0	15	0
	c2	Minimum compressor OFF time	WE00S% and WE00C%	min	C	0	15	0
	c3	Minimum compressor ON time	WE00S% and WE00C%	min	C	0	15	0
	c4	Compressor running time with duty setting	WE00S% and WE00C%	min	C	0	100	0
	cc	Continuous cycle duration	WE00S% and WE00C%	ore	C	0	15	0
	c6	Low temperature alarm bypass after continuous cycle	WE00S% and WE00C%	ore	C	0	250	2
	c7	Maximum pump down time (PD) 0: pump down disabled	WE00S% and WE00C%	s	C	0	900	0
	c9	Enable autostart function in PD 0: disabled 1: pump down whenever closing pump down & following low pressure switch activation with no cooling demand	WE00S% and WE00C%	flag	C	0	1	0
	c10	Pump down by time or pressure 0: Pump down by pressure 1: Pump down by time	WE00S% and WE00C%	flag	C	0	1	0
	c11	Second compressor start delay	WE00S% and WE00C%	s	C	0	250	4

Symbol	Code	Parameter	Models	UOM	Type	Min.	Max.	Def.
	d0	Typo of defrost 0: Electric heater by temperature 1: Hot gas by temperature 2: Electric heater by time (Ed1, Ed2 not shown) 3: Hot gas by time (Ed1, Ed2 not shown) 4: Electric heater by time with temperature control (Ed1, Ed2 not shown)	WE00S% and WE00C%	flag	C	0	4	0
	dl	MAximum time between consecutive defrosts 0: defrost not performed	WE00S% and WE00C%	ore	F	0	250	8
	dt1	End defrost temperature probe 2	WE00S% and WE00C%	°C/°F	F	-50	200	4.0
	dt2	End defrost temperature probe 3	WE00S% and WE00C%	°C/°F	F	-50	200	4.0
	dP1	Maximum defrost duration	WE00S% and WE00C%	min	F	1	250	30
	dP2	Maximum defrost duration, aux evaporator	WE00S% and WE00C%	min	F	1	250	30
	d3	Defrost activation delay	WE00S% and WE00C%	min	C	0	250	0
	d4	Defrost at start-up 0: disabled 1: enabled	WE00S% and WE00C%	flag	C	0	1	0
	d5	Defrost delay on start-up (if d4=1) or from DI	WE00S% and WE00C%	min	C	0	250	0
	d6	Terminal display during defrost 0: Alternating display of temperature and dEF value 1: display disabled 2: dEF	WE00S% and WE00C%	-	C	0	2	1
	dd	Dripping time after defrost (fans off)	WE00S% and WE00C%	min	F	0	15	2
	d8	High temperature alarm bypass time after defrost (and door open)	WE00S% and WE00C%	ore	F	0	250	1
	d8d	Alarm bypass time after door open	WE00S% and WE00C%	min	C	0	250	0
	d9	Defrost priority over compressor protectors 0: The protection times c1, c2 and c3 are observed 1: The protection times c1, c2 and c3 are not observed	WE00S% and WE00C%	flag	C	0	1	0
	d/1	Display of defrost probe 1	WE00S% and WE00C%	°C/°F	F	-	-	-
	d/2	Display of defrost probe 2	WE00S% and WE00C%	°C/°F	F	-	-	-
	dC	Time base for defrost 0: dl in hours, dP1 and dP2 in minutes 1: dl in minutes, dP1 and dP2 in seconds	WE00S% and WE00C%	flag	C	0	1	0
	d10	Defrost time in running time mode 0= function disabled	WE00S% and WE00C%	ore	C	0	250	0
	d11	Running time defrost temperature threshold	WE00S% and WE00C%	°C/°F	C	-20	20	1.0
	d12	Advanced defrost	WE00S% and WE00C%	-	C	0	3	0
	dn	Nominal defrost duration	WE00S% and WE00C%	-	C	1	100	65
	dH	Proportional factor for variation of dl	WE00S% and WE00C%	-	C	0	100	50
	A0	Alarm and fan differential	WE00S% and WE00C%	°C/°F	C	0.1	20	2.0
	A1	Alarm threshold ('AL' and 'AH') relative to set point or absolute 0: AL and AH are relative thresholds to the set point 1: AL and AH are absolute thresholds	WE00S% and WE00C%	flag	C	0	1	0
	AL	Low temperature alarm threshold	WE00S% and WE00C%	°C/°F	F	-50	200	0.0
	AH	High temperature alarm threshold	WE00S% and WE00C%	°C/°F	F	-50	200	0.0
	Ad	Low and high temperature alarm delay	WE00S% and WE00C%	min	F	0	250	120
	A4	Digital input 1 configuration (DI1) 0: Input not active 1: Immediate external alarm 2: Delayed external alarm 3: If model M, probe selection 3: Other models enable defrost 4: Start defrost 5: Door switch with compressor and fan stop 6: Remote on/off 7: Curtain switch 8: Low pressure switch 9: Door switch with fan stop 10: Direct/reverse operation 11: Light sensor 12: Activation of AUX output 13: Door switch with compressor and fans off and light not managed 14: Door switch with fans off and light not managed	WE00S% and WE00C%	- -	C C	0 0	14 14	0 3
	A5	Digital input 2 configuration (DI2) / As for A4	WE00S% and WE00C%	-	C	0	14	0
	A6	Stop compressor from external alarm	WE00S% and WE00C%	min	C	0	100	0
	A7	Digital alarm input delay	WE00S% and WE00C%	min	C	0	250	0
	A8	Enable alarms 'Ed1' and 'Ed2' (end defrost by timeout) 0: Alarm signals Ed1 and Ed2 enabled 1: Alarm signals Ed1 and Ed2 disabled	WE00S% and WE00C%	flag	C	0	1	0
	Ado	Light management with door switch	WE00S% and WE00C%	flag	C	0	1	0
	Ac	High condenser temperature alarm threshold	WE00S% and WE00C%	°C/°F	C	0.0	200	70
	AE	High condenser temperature alarm differential	WE00S% and WE00C%	°C/°F	C	0.1	20	10
	Acd	High condenser temperature alarm delay	WE00S% and WE00C%	min	C	0	250	0
	AF	Light sensor OFF time	WE00S% and WE00C%	s	C	0	250	0
	ALF	Antifreeze alarm threshold	WE00S% and WE00C%	°C/°F	C	-50	200	-5
	AdF	Antifreeze alarm delay	WE00S% and WE00C%	min	C	0	15	1



Symbol	Code	Parameter	Models	UOM	Type	Min.	Max.	Def.																																																																																								
	F0	Evaporator fan management 0: always on 1: Activation based on Sd-Sv ( difference between virtual probe and evaporator temperature) 2: Activation based on Sd (evaporator temperature)	WE00C%	flag	C	0	2	0																																																																																								
	F1	Fan activation temperature (only if F0= 1 or 2)	WE00C%	°C/°F	F	-50	200	5																																																																																								
	F2	Evaporator fans with compressor OFF 0: see F0 1: always off	WE00C%	flag	C	0	1	1																																																																																								
	F3	Evaporator fans during defrost 0: Fans operate 1: Fans do not operate	WE00C%	flag	C	0	1	1																																																																																								
	Fd	Post dripping time (fans OFF)	WE00C%	min	F	0	15	1																																																																																								
	F4	Condenser fan stop temperature	WE00C%	°C/°F	C	-50	200	40																																																																																								
	F5	Condenser fan start differential	WE00C%	°C/°F	C	0.1	20	5																																																																																								
	H0	Serial address	WE00S% and WE00C%	-	C	0	207	1																																																																																								
	H1	AUX1 output configuration 0: normally energised alarm 1: normally de-energised alarm 2: Auxiliary 3: Light 4: Auxiliary evaporator defrost 5: Pump down valve 6: Condenser fan 7: Delayed compressor 8: Auxiliary with deactivation when OFF 9: Light with deactivation when OFF 10: No function 11: Reverse with neutral zone 12: Second compressor step 13: Second compressor step with rotation	WE00C%	flag	C	0	13	1																																																																																								
	H2	Disable keypad/ir  <table border="1" style="margin-left: 20px;"> <thead> <tr> <th>Parameter "H2"</th> <th>LIGHT</th> <th>ON/OFF</th> <th>AUX</th> <th>HACCP</th> <th>PRG/MUTE (mute)</th> <th>UP/CC</th> <th>DOWN/DEF</th> <th>SET</th> <th>parameter F modification</th> <th>Set point modification</th> </tr> </thead> <tbody> <tr><td>0</td><td></td><td></td><td></td><td></td><td></td><td></td><td></td><td></td><td>.</td><td>.</td></tr> <tr><td>1</td><td></td><td></td><td></td><td></td><td></td><td></td><td></td><td></td><td>.</td><td>.</td></tr> <tr><td>2</td><td></td><td></td><td></td><td></td><td></td><td></td><td></td><td></td><td>.</td><td>.</td></tr> <tr><td>3</td><td></td><td></td><td></td><td></td><td></td><td></td><td></td><td></td><td>.</td><td>.</td></tr> <tr><td>4</td><td>.</td><td></td><td></td><td></td><td>.</td><td>.</td><td></td><td>.</td><td>.</td><td>.</td></tr> <tr><td>5</td><td>.</td><td></td><td></td><td></td><td>.</td><td>.</td><td></td><td>.</td><td>.</td><td>.</td></tr> <tr><td>6</td><td></td><td></td><td></td><td></td><td>.</td><td>.</td><td></td><td>.</td><td>.</td><td>.</td></tr> </tbody> </table> Keypad function ". " = Disabled	Parameter "H2"	LIGHT	ON/OFF	AUX	HACCP	PRG/MUTE (mute)	UP/CC	DOWN/DEF	SET	parameter F modification	Set point modification	0									.	.	1									.	.	2									.	.	3									.	.	4	.				.	.		.	.	.	5	.				.	.		.	.	.	6					.	.		.	.	.	WE00S% and WE00C%	flag	C	0	6	1
	Parameter "H2"	LIGHT	ON/OFF	AUX	HACCP	PRG/MUTE (mute)	UP/CC	DOWN/DEF	SET	parameter F modification	Set point modification																																																																																					
	0									.	.																																																																																					
	1									.	.																																																																																					
	2									.	.																																																																																					
	3									.	.																																																																																					
	4	.				.	.		.	.	.																																																																																					
	5	.				.	.		.	.	.																																																																																					
6					.	.		.	.	.																																																																																						
H4	Buzzer 0: enabled 1: disabled	WE00S% and WE00C%	flag	C	0	1	0																																																																																									
H6	Terminal keypad lock configuration	WE00S% and WE00C%	-	C	0	255	0																																																																																									
H8	Output switched with scheduler 0: light 1: Aux	WE00S% and WE00C%	flag	C	0	1	0																																																																																									
H9	Set point variation with time band 0: Set point variation with time band disabled 1: Set point variation with time band enabled	WE00S% and WE00C%	flag	C	0	1	0																																																																																									
Hdh	Anti-sweat heater offset	WE00S% and WE00C%	°C/°F	C	-50	200	0																																																																																									

Tab. 7.a

## 8. SIGNALS AND ALARMS

Since SmartCella has the same ir33+ logic, please refer to ir33+ manual code +0300028EN

Code on display	Cause of the alarm	Icon flashing on display	Alarm relay	Buzzer	Reset	PD valve	Compressor	Defrost	Evaporator fans	Condenser fans	Continuous cycle	AUX neutral zone	AUX light Anti-sweat	AUX auxiliary Anti-sweat	AUX second step
rE	Virtual control probe fault		ON	ON	autom.	duty setting (c4)	duty setting (c4)	-	-	-	-	OFF	OFF	OFF	duty setting (c4)
E0	Probe S1 fault		OFF	OFF	autom.	duty setting (c4)	duty setting (c4)	-	-	-	-	OFF	OFF	OFF	duty setting (c4)
E1	Probe S2 fault		OFF	OFF	automatic	-	-	-	-	-	-	-	-	-	-
E2	Probe S3 fault		OFF	OFF	autom.	-	-	-	-	-	-	-	-	-	-
E3	Probe S4 fault		OFF	OFF	autom.	-	-	-	-	-	-	-	-	-	-
LO	Low temperature alarm		ON	ON	autom.	-	-	-	-	-	-	-	-	-	-
HI	High temperature alarm		ON	ON	autom.	-	-	-	-	-	-	-	OFF	OFF	-
Afr	Frost protection alarm		ON	ON	manual	OFF	OFF	-	-	-	-	-	-	-	OFF
IA	Immediate alarm from external contact		ON	ON	automatic	duty setting (A6)	duty setting (A6)	-	-	-	-	OFF	OFF	OFF	duty setting (A6)
dA	Delayed alarm from external contact		ON	ON	automatic	duty setting (A6)	-	-	-	-	-	OFF if A7≠0	OFF if A7≠0	OFF if A7≠0	duty setting (A6) if A7≠0
Pd	Alarm maximum pump down time		ON	ON	automatic/manual	-	-	-	-	-	-	-	-	-	-
LP	Low pressure alarm		ON	ON	automatic/manual	OFF	OFF	-	-	-	-	-	-	-	OFF
AtS	Autostart in pump down		ON	ON	automatic/manual	-	-	-	-	-	-	-	-	-	-
cht	High condenser temp. pre-alarm	-	OFF	OFF	automatic/manual	-	-	-	-	-	-	-	-	-	-
CHt	High condenser temperature alarm		ON	ON	manual	OFF	OFF	-	-	-	-	-	OFF	OFF	OFF
dor	Door open for too long alarm		ON	ON	automatic	-	-	-	-	-	-	-	-	-	-
EE	Unit parameter EEPROM error		OFF	OFF	automatic	OFF	OFF	not run	OFF	OFF	not run	OFF	OFF	OFF	OFF
EF	Operating parameter EEPROM error		OFF	OFF	automatic	OFF	OFF	not run	OFF	OFF	not run	OFF	OFF	OFF	OFF

Tab. 8.a

## 9. TECHNICAL SPECIFICATION

power supply	Model	Voltage	Power	
	E	230 V~ (+10%, -15%), 50/60 Hz	3 VA, 25 mA~ max.	
	A	115 V~ (+10%, -15%) 50/60 Hz	3 VA, 50 mA~ max.	
	H	115...230 V~ (+10%, -15%), 50/60 Hz	6 VA, 50 mA~ max.	
	L	12...24 V~ (+10%, -15%), 50/60 Hz, 12...30 Vdc	3 VA, 300 mA~ /mAdc max.	
	0	12 V~, 50/60 Hz, 12...18 Vdc	Use only TRA12VDE00 power supply transformer with 315 mA slow -blow fuse in the secondary	
Insulation guaranteed by the power supply	E, A, H	insulation in reference to very low voltage parts	reinforced, 6 mm clearance, 8 mm creepage, 3750 V insulation	
		insulation from relay outputs	basic, 3 mm clearance, 4 mm creepage, 1250 V insulation	
	0, L	insulation in reference to very low voltage parts	externally guaranteed by safety transformer (SELV power supply)	
		insulation from relay outputs	reinforced, 6 mm clearance, 8 mm creepage, 3750 V insulation	
Inputs	S1 (probe 1)	NTC		
	S2 (probe 2)	NTC		
	DI1	free contact, contact resistance < 10 Ω, closing current 6 mA NTC		
	S3 (probe 3)			
	DI2	free contact, contact resistance < 10 Ω, closing current 6 mA NTC		
	S4 (probe 4)			
	Maximum distance of probes and digital inputs less than 10 m During installation keep the power and loads connection separate from probe cables, digital inputs, repeater display and supervisory system			
Probe type	NTC std. CAREL	10 kΩ a 25 °C, range -50T90 °C		
		measurement error	1 °C nel range -50T50 °C 3 °C nel range 50T90 °C	
	NTC high temperature	50 kΩ a 25 °C, range -40T150 °C		
		measurement error	1,5 °C nel range -20T115 °C 4 °C nel range esterno a -20T115 °C	
Relay outputs	depending on the model			
		EN60730-1	UL873	
	relè / relay	250 V~	operating cycles	250 V~
	8 A(*)	8(4)A on N.O. 6(4)A on N.C. 2(2)A on N.O. and N.C.	100000	8 A res. 2 FLA 12 LRA C300 30000
	16 (*)	10(4) A until to 60 °C su N.O. 12(2)A on N.O. and N.C.	100000	12 A res. 5 FLA 30 LRA C300 30000
	2 Hp	10(10)A	100000	12 A res. 12 FLA 72 LRA C300 30000
		(*) : Relay not suitable for fluorescent loads (neon lights, ...) that use starters (ballasts) with phase-shift capacitors. Fluorescent lamps with electronic control devices or without phase-shift capacitors can be used, within the operating limits specified for each type of relay.		
	insulation in reference to very low voltage parts	reinforced, 6 mm clearance, 8 mm creepage, 3750 V insulation		
	insulation between the relay outputs independent	basic, 3 mm clearance, 4 mm creepage, 1250 V insulation		
Connections	wire section 0,5 - 2,5 mq max current 12A			
	Type of connection	wire section	max current	
	fixed screw-on	0,5 - 2,5 mq	12 A	
	emovable for screw blocks			
	sezione conduttori per sonde e ingressi digitali	0,5 - 2,5 mq	da 20 a 13 AWG	
sezione conduttori per alimentazione e carichi	0,5 - 2,5 mq	da 15 a 13 AWG		
	The installer has to provide the correct dimensioning of the power supply and cable connection between the instruments and the loads. Depending on the model, the maximum current in the common terminals 1, 3 or 5 is 12 A. When using the controller at maximum operating temperature and full load, use cables featuring a maximum operating temperature of 105 °C at least.			
Case	plastic	dimensions 128x290x101 mm		
Display	digits	3 digit LED		
	display range	from -99 to 999		
	operating status	indicated by graphic icons on the display		
Keypad	4 buttons membrane keypad			
Buzzer	available on all the models			
Operating temperature	models 0,L,H -10T50 °C models E,A -10T45°C			
Operating humidity	<90% r.H. non-condensing			
Storage temperature	-20T70 °C			
Storage humidity	<90% r.H. non-condensing			
Front panel degree of protection	front panel IP65			
Control pollution status	2 (normal situation)			
PTI of the insulating material	printed circuit board 250, insulation 175			
Period of electric stress across insulating parts	long			
Heat and fire resistance category	category D and category B (UL 94-V0)			
Class of protection against voltage surges	category II			
Type of disconnection or interruption	1.B relay contacts (micro-disconnection)			
Construction of control	incorporated control, electronically			
Classification according to protection against electric shock	Class II, by appropriate incorporation			
The control is either to be hand-held or is intended for a hand-held equipment	no			

Software class and structure	class A
Front panel cleaning	use only neutral detergents and water
Serial interface for CAREL network	external, available on all models
Interface for repeater display	external, available on models with H, L and 0 power supply
Maximum distance between interface and display	10 m
Programming key	available on all models
Safety standards: compliant with the European reference standards.	

Tab. 9.a

## 10. ADVANCED FUNCTIONS

Since SmartCella has the same ir33+ logic, please refer to ir33+ manual code +0300028EN