

## SC12MLX MBP Compressor R404A/R507 208-230V 60Hz & 220-240V 50Hz

### General

Code number	104L2606
Approvals	EN 60335-2-34, UL984
Compressors on pallet	80

### Application

Application	MBP			
	Hz	50	60	
Frequency	Hz	50	60	
Evaporating temperature	°C	-23.3 to 7.2	-23.3 to 7.2	
Voltage range	V	187 - 254	187 - 254	
Max. condensing temperature continuous (short)	°C	50 (60)	50 (60)	
Max. winding temperature continuous (short)	°C	125 (135)	125 (135)	

### Cooling requirements

Frequency	Hz	50			60		
		LBP	MBP	HBP	LBP	MBP	HBP
32°C		-	F <sub>2</sub>	-	-	F <sub>2</sub>	-
38°C		-	F <sub>2</sub>	-	-	F <sub>2</sub>	-
43°C		-	F <sub>2</sub>	-	-	F <sub>2</sub>	-

Remarks on application:  
Not applicable for 208V 60Hz at 0°C or higher evaporating temperature.

### Motor

Motor type	CSIR		
LRA (rated after 4 sec. UL984), HST   LST	A	23.4	-
Cut in Current, HST   LST	A	23.4	-
Resistance, main   start winding (25°C)	Ω	3.4	14.4

### Design

Displacement	cm <sup>3</sup>	12.87
Oil quantity (type)	cm <sup>3</sup>	600 (polyolester)
Maximum refrigerant charge	g	1300
Free gas volume in compressor	cm <sup>3</sup>	1460
Weight without electrical equipment	kg	13.9

### Dimensions

Height	mm	A	219
		B	213
		B1	193
		B2	110
Suction connector	location/I.D. mm   angle	C	8.2   37°
	material   comment	Copper   Rubber plug	
Process connector	location/I.D. mm   angle	D	6.5   37°
	material   comment	Copper   Rubber plug	
Discharge connector	location/I.D. mm   angle	E	6.5   37°
	material   comment	Copper   Rubber plug	
Oil cooler connector	location/I.D. mm   angle	F	-
	material   comment	-	
Connector tolerance	I.D. mm		±0.09
Remarks:			

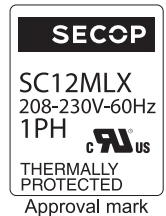
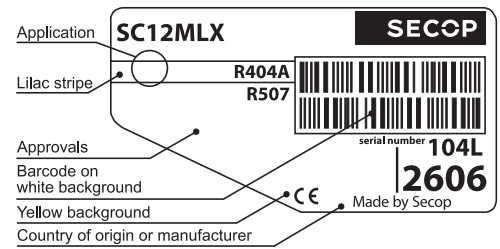

- S = Static cooling normally sufficient
- O = Oil cooling
- F<sub>1</sub> = Fan cooling 1.5 m/s (compressor compartment temperature equal to ambient temperature)
- F<sub>2</sub> = Fan cooling 3.0 m/s necessary
- SG = Suction gas cooling normally sufficient
- = not applicable in this area

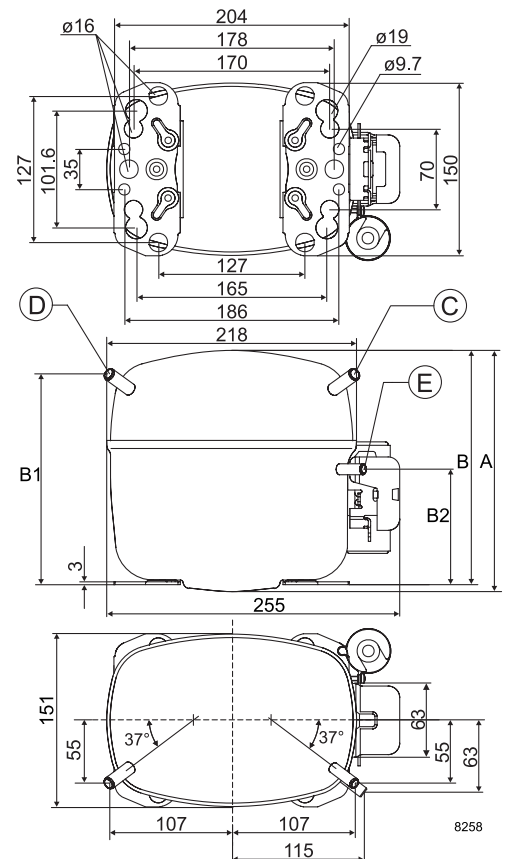

**ASHRAE MBP**

 230V, 60Hz, fan cooling F<sub>2</sub>

Evap. temp. in °C	-45	-40	-35	-30	-25	-23.3	-20	-15	-10	-6.7	-5	0	5	7.2	10	15	20
Capacity in W						554	667	859	1080	1245	1335	1629	1965	2127			
Power cons. in W						552	609	692	775	830	860	949	1046	1092			
Current cons. in A						3.39	3.57	3.87	4.21	4.46	4.59	5.01	5.47	5.68			
COP in W/W						1.00	1.10	1.24	1.39	1.50	1.55	1.72	1.88	1.95			

**ASHRAE MBP**

 220V, 50Hz, fan cooling F<sub>2</sub>

Evap. temp. in °C	-45	-40	-35	-30	-25	-23.3	-20	-15	-10	-6.7	-5	0	5	7.2	10	15	20
Capacity in W						498	592	754	942	1083	1162	1415	1706	1847			
Power cons. in W						507	548	609	667	705	724	780	836	860			
Current cons. in A						3.72	3.84	4.03	4.25	4.40	4.48	4.72	4.99	5.11			
COP in W/W						0.98	1.08	1.24	1.41	1.54	1.60	1.81	2.04	2.15			

**EN 12900 Household (CECOMAF)\***

 230V, 60Hz, fan cooling F<sub>2</sub>

Evap. temp. in °C	-45	-40	-35	-30	-25	-23.3	-20	-15	-10	-6.7	-5	0	5	7.2	10	15	20
Capacity in W						659	773	970	1199	1370	1465	1770	2118	2286			
Power cons. in W						561	601	664	729	776	801	882	975	1021			
Current cons. in A						3.38	3.52	3.76	4.05	4.26	4.37	4.73	5.14	5.32			
COP in W/W						1.18	1.29	1.46	1.64	1.77	1.83	2.01	2.17	2.24			

**EN 12900 Household (CECOMAF)\***

 220V, 50Hz, fan cooling F<sub>2</sub>

Evap. temp. in °C	-45	-40	-35	-30	-25	-23.3	-20	-15	-10	-6.7	-5	0	5	7.2	10	15	20
Capacity in W						572	669	838	1038	1188	1272	1542	1852	2001			
Power cons. in W						493	525	572	620	651	667	714	762	783			
Current cons. in A						3.67	3.76	3.91	4.08	4.20	4.27	4.47	4.69	4.79			
COP in W/W						1.16	1.27	1.46	1.68	1.83	1.91	2.16	2.43	2.55			

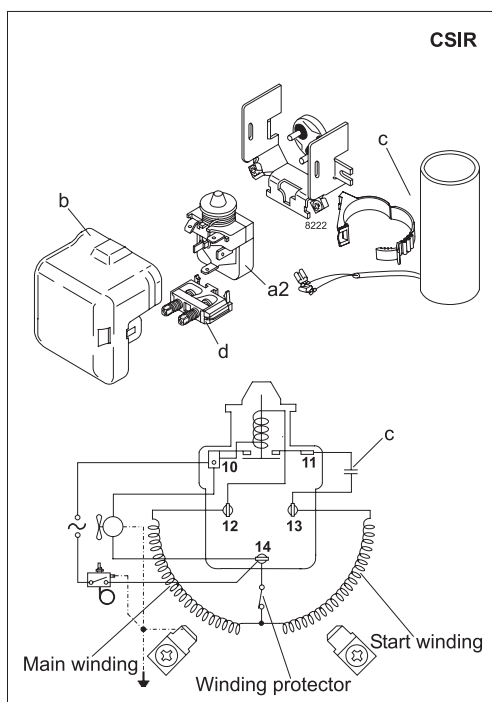

Accessories for	SC12MLX	Figure	Code number
PTC starting device	6.3 mm spade connectors	a1	—
	4.8 mm spade connectors		—
Starting relay	6.3 mm spade connectors	a2	117U6011
Cover		b	103N2008
Start. capacitor 80 µF	6.3 mm spade connectors	c	117U5017
Cord relief		d	103N1004
Protection screen for PTC		g	—

Test conditions	EN 12900/ CECOMAF*	ASHRAE MBP
Condensing temperature	45°C	54.4°C
Ambient temperature	32°C	35°C
Suction gas temperature	32°C	35°C
Liquid temperature	no subcooling	46.1°C

Mounting accessories		Code number
Bolt joint for one comp.	Ø: 16 mm	118-1917
Bolt joint in quantities	Ø: 16 mm	118-1918
Snap-on in quantities	Ø: 16 mm	118-1919

Secop can accept no responsibility for possible errors in catalogues, brochures and other printed material. Secop reserves the right to alter its products without notice. This also applies to products already on order provided that such alterations can be made without consequential changes being necessary in specifications already agreed. All trademarks in this material are property of the respective companies. Secop and the Secop logotype are trademarks of Secop GmbH. All rights reserved. [www.secop.com](http://www.secop.com)