

SC10G Universal Compressor R134a 220-240V 50/60Hz

General

Code number	104G8000
Approvals	EN 60335-2-34
Compressors on pallet	80

Application

Application	LBP/HBP	LBP/MBP
Frequency	50	60
Evaporating temperature	-35 to 15	-35 to -5
Voltage range	187 - 254	198 - 254
Max. condensing temperature continuous (short)	60 (70)	60 (70)
Max. winding temperature continuous (short)	125 (135)	125 (135)

Cooling requirements

Frequency	Hz	50			60		
Application		LBP	MBP	HBP	LBP	MBP	HBP
32°C		F ₁	F ₂	F ₂	F ₁	F ₂	-
38°C		F ₁	F ₂	F ₂	F ₁	F ₂	-
43°C		F ₁	F ₂	F ₂	F ₁	F ₂	-
Remarks on application:							

Motor

Motor type	RSIR/CSIR	
LRA (rated after 4 sec. UL984), HST LST	A	11.1 10.2
Cut in Current, HST LST	A	11.1 14.6
Resistance, main start winding (25°C)	Ω	8.5 14.1

Design

Displacement	cm ³	10.29
Oil quantity (type)	cm ³	550 (polyolester)
Maximum refrigerant charge	g	1300
Free gas volume in compressor	cm ³	1510
Weight without electrical equipment	kg	12.1

Dimensions

Height	mm	A	199
		B	193
		B1	173
		B2	90
Suction connector	location/I.D. mm angle	C	8.2 37°
	material comment	Copper Rubber plug	
Process connector	location/I.D. mm angle	D	6.2 37°
	material comment	Copper Rubber plug	
Discharge connector	location/I.D. mm angle	E	6.2 37°
	material comment	Copper Rubber plug	
Oil cooler connector	location/I.D. mm angle	F	-
	material comment	-	
Connector tolerance	I.D. mm		±0.09
Remarks:			

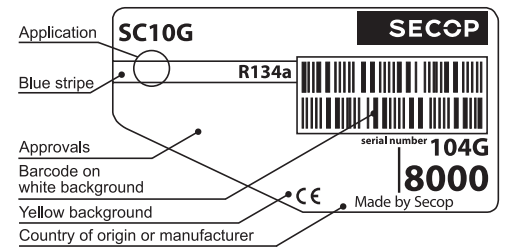

- S = Static cooling normally sufficient
- O = Oil cooling
- F₁ = Fan cooling 1.5 m/s
(compressor compartment temperature equal to ambient temperature)
- F₂ = Fan cooling 3.0 m/s necessary
- SG = Suction gas cooling normally sufficient
- = not applicable in this area

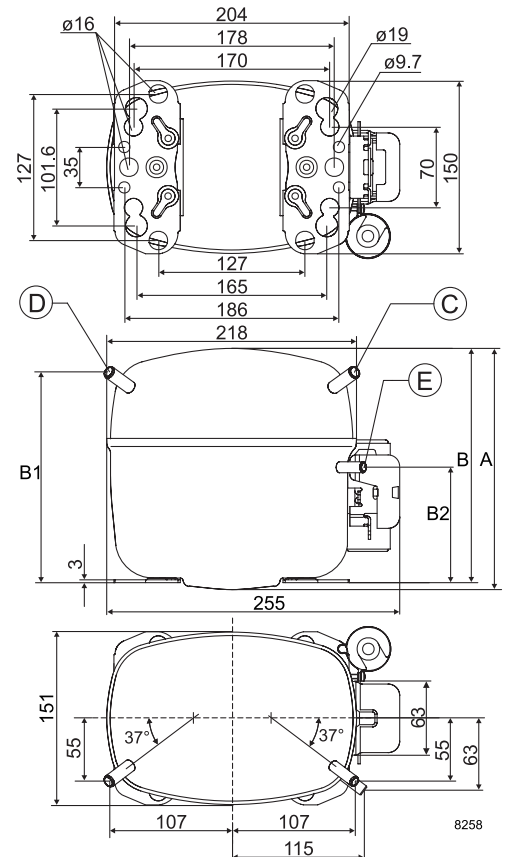

EN 12900 Household (CECOMAF)

220V, 50Hz, fan cooling F₁

Evap. temp. in °C	-45	-40	-35	-30	-25	-23.3	-20	-15	-10	-6.7	-5	0	5	7.2	10	15	20
Capacity in W			23	60	113	135	183	268	369	445	486	618	764	833	925	1100	
Power cons. in W			93	139	181	195	220	256	290	311	322	353	383	396	412	441	
Current cons. in A			1.29	1.34	1.41	1.44	1.50	1.61	1.72	1.8	1.85	1.98	2.12	2.18	2.26	2.40	
COP in W/W			0.25	0.43	0.63	0.69	0.83	1.05	1.27	1.43	1.51	1.75	2.00	2.11	2.25	2.49	

ASHRAE LBP

220V, 50Hz, fan cooling F₁

Evap. temp. in °C	-45	-40	-35	-30	-25	-23.3	-20	-15	-10	-6.7	-5	0	5	7.2	10	15	20
Capacity in W			29	74	139	166	225	331	456	550	600	764	946	1032	1147	1367	
Power cons. in W			93	139	181	195	220	256	290	311	322	353	383	396	412	441	
Current cons. in A			1.29	1.34	1.41	1.44	1.50	1.61	1.72	1.8	1.85	1.98	2.12	2.18	2.26	2.40	
COP in W/W			0.31	0.53	0.77	0.85	1.02	1.29	1.57	1.80	1.86	2.16	2.47	2.61	2.78	3.10	

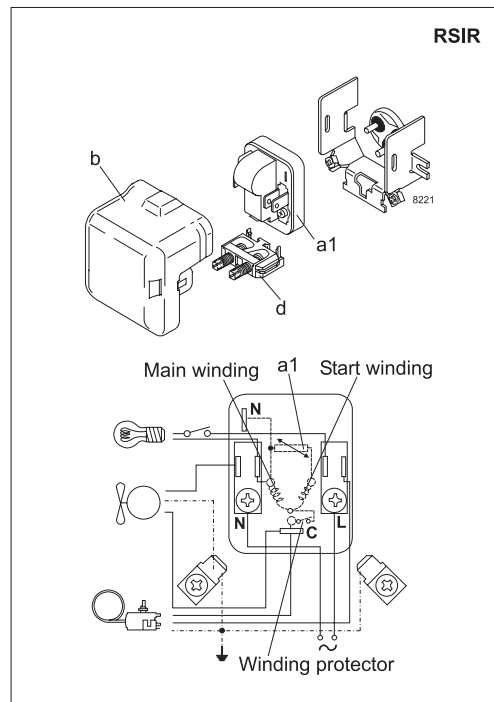
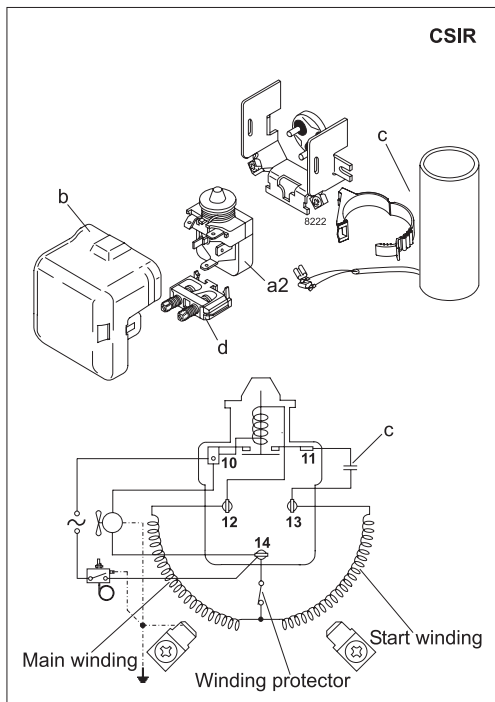

Accessories for	SC10G	Figure	Code number
PTC starting device	6.3 mm spade connectors	a1	103N0011
	4.8 mm spade connectors		-
Starting relay	6.3 mm spade connectors	a2	117U6002
Cover		b	103N2009
Start. capacitor 80 µF	6.3 mm spade connectors	c	117U5017
Cord relief		d	103N1004
Protection screen for PTC		g	-

Test conditions	EN 12900/CECOMAF	ASHRAE LBP
Condensing temperature	55°C	55°C
Ambient temperature	32°C	32°C
Suction gas temperature	32°C	32°C
Liquid temperature	55°C	32°C

Mounting accessories		Code number
Bolt joint for one comp.	Ø: 16 mm	118-1917
Bolt joint in quantities	Ø: 16 mm	118-1918
Snap-on in quantities	Ø: 16 mm	118-1919

Secop can accept no responsibility for possible errors in catalogues, brochures and other printed material. Secop reserves the right to alter its products without notice. This also applies to products already on order provided that such alterations can be made without consequential changes being necessary in specifications already agreed. All trademarks in this material are property of the respective companies. Secop and the Secop logotype are trademarks of Secop GmbH. All rights reserved. www.secop.com