

Specifications No.

C-2126

04-AUG-2006

CUSTOMER: HEL**COMPRESSOR SPECIFICATIONS**Compressor type : Scroll Compressor (Algebraic type)

Refrigerant : R404A

Power source : 3PH, 380 – 415V, 50Hz

Model Name	Nominal Capacity [W]	Motor Rated Output [W] ([HP])
DS1529V1	1,500	1,500 (2.0)
DS1834V1	1,740	1,800 (2.5)
DS2244V1	2,230	2,200 (3.0)

We acknowledge the receipt of this copy.

Please return this compressor specifications after confirming the contents. If you do not return this copy by the above date, we will assume that you have checked the contents.

Hitachi Appliances, Inc.
Devices Department

APPD.	CHKD.	DWN.
<i>A. Shimada</i>	<i>M. Onoguchi</i>	<i>W. Sugawara</i>

NOTE

The Specifications in this bulletin are subject to change without notice, in order that HITACHI may bring the latest innovations to our customers.



SAFETY PRECAUTION

Read and understand all of the safety precautions in this manual before operating the product.





These precautions are intended to ensure safe and correct operation of the product and to prevent injury to the operator and other persons and damage to the product.

Observe these precautions strictly.

The following symbols indicate the presence of potentially hazardous conditions.

 WARNING	This symbol indicates a potentially hazardous situation which, if not avoided, <u>could result in</u> death or serious injury.
 CAUTION	This symbol indicates a potentially hazardous situation which, if not avoided, <u>may result in</u> minor or moderate injury or property damage accidents to the product. It may also be used to alert against unsafe practices.

The meanings of the graphic symbols in text are shown below.

	<u>Be sure to perform</u> the operation.
	<u>Disconnect</u> the power cable from the electrical outlet.
	<u>Connect</u> the grounding wire.
	<u>Prohibit</u> .

WARNING



Provide the refrigerating cycle unit with adequate electrical grounding. Incomplete grounding could result in electrical shock hazards in the event of troubles and current leakage.



Connect a fuse or a leak circuit breaker to the main circuit to avoid electrical shock hazards or fire in the event of troubles and current leakage.



Check to see that the main power is turned off, before repairing, to avoid electrical shock hazards in case of touching the terminals.



Measure the temperature of the hermetic terminals of the compressor and then connect the appropriate lead wires.

Lead wire insulation deterioration (thermal deterioration) could result in electrical shock hazards, short-circuiting, or fire.



Keep the lead wires away from the surface of the compressor or the piping.

Lead wire insulation deterioration (thermal deterioration) could result in electrical shock hazards, short-circuiting, or fire.



Keep the lead wires away from any rotational parts like fans or any vibrational parts like piping.

Lead wire insulation deterioration due to vibration or friction could result in electrical shock hazards, short-circuiting, or fire.



Do NOT make the compressor self-evacuated during operation, which avoids overheating the compressor that could cause burns or fire.



Do NOT touch the surface of the compressor with empty hands, which avoids burns. The surface is very hot during operation and immediately after it has stopped.



Do NOT use this compressor for air compression, which avoids overheating of the compressor that could cause burns or fire.



Do NOT view the inspection window of the compressor for internal observation directly. Use a video camera or other suitable equipment to avoid serious injury owing to explosion of the inspection window or blowout of the refrigerant.



Wear protective goggles during repairs to avoid serious injury owing to explosion of piping or blowout of the refrigerant.

CAUTION



Do NOT install the compressor in a humid place or locations exposed to water. Do NOT dip it into water or spray it with water. In case of using the sound insulation material to enclose the compressor, which is highly hygroscopic, that material must NOT absorb water. Insulation deterioration causes electrical shock hazards, current leakage, short-circuiting, or explosion owing to corrosion.



Attach the specified cover to the hermetic terminals of the compressor by the specified method to prevent entry of dirt.

Incomplete electrical conduction of the hermetic terminals may cause troubles or fire.



Do NOT apply electrical pulse to the compressor while its inside is maintained in a vacuum. It avoids insulation failure inside the compressor, which may result in electrical shock hazards, current leakage, or fire.



Store the compressor in clean and dry environment. Insulation failure of the hermetic terminals of the compressor may result in electrical shock hazards or current leakage. Corrosion of the compressor surface may result in explosion. Blowout of the refrigerant may result in burns.



In case of attaching cluster terminals, the PTC starter, receptacle terminals, or other electrical parts to the hermetic terminals of the compressor, those parts must NOT be obliquely connected or twisted after connections, which avoids reducing fastening force of the terminals. Incomplete electrical conduction of the hermetic terminals may cause troubles or fire.

1. GENERAL SPECIFICATIONS

Model		DS1529V1	DS1834V1	DS2244V1							
Nominal Output	HP	2	2.5	3.0							
	W	1,500	1,800	2,200							
Power Supply	-	3 phase, 380 - 415 V, 50 Hz									
Refrigerant	-	R404A									
Allowable amount of Refrigerant Charge	g	3,000	3,000	4,000							
Refrigerant Oil	-	POE (VG68)									
Oil Charge	liter	0.85	0.85	1.15							
Displacement	cm ³ /rev	29.1	34.0	44.0							
	m ³ /h	5.03	5.88	7.60							
Rated Revolution	min ⁻¹	2,880									
Performance ⁽¹⁾											
Cooling Capacity	W	1,500	1,740	2,230							
Power Input	W	1,180	1,360	1,700							
COP	-	1.27	1.28	1.31							
Sound Level and Vibration Level ⁽²⁾											
Sound Level ⁽³⁾	dB(A)	MAX . 65	MAX . 68	MAX . 70							
Vibration Level ⁽⁴⁾	μ m	MAX . 50	MAX . 60	MAX . 71							
Net Weight (Including Oil)	kg	23	23	24							
Piping ⁽⁵⁾ Connection	Suction	-	16.1 I.D. (BR)								
	Discharge	-	9.72 I.D. (BR)								
	Injection	-	6.2 I.D. (BR)								
Motor	Type	-	Induction run								
	Poles	-	2								
	Voltage	V	380	415	380	415	380	415			
	Starting Current	A	22	24	22	24	26	31			
	Max. Continuous Current	A	4.0		4.6		5.9				
	Winding resistance (at20)		U-V	V-W	W-U	U-V	V-W	W-U	U-V	V-W	W-U
		Ohm	7.433	7.359	7.652	7.433	7.359	7.652	5.872	5.805	6.049
Capacitor	Starting Capacitor	-	-	-	-	-	-	-			
	Running Capacitor	-	-	-	-	-	-	-			
Starting Relay	-	-	-	-	-	-	-				

[notes]

(1) Above performance is based on the following conditions

Evaporating Temperature	- 30.0
Condensing Temperature	40.0
Return gas Temperature	18.0
Liquid Temperature before Expansion Valve	35
Ambient Temperature	32.0
Compressor Cooling	Fan Cooling + Liquid Injection

(2) Measurement condition for Sound and Vibration Level.

Suction Pressure	0.202 MPa
Discharge Pressure	1.811 MPa
Noise of soundproof room	under 40 dBA
Vibration of soundproof room	under 5 μ m
Return gas temp.	18.0 °C
Liquid refrigerant back	No liquid back
Draft	No draf

(3)

Sound level is measured at the point 30 cm away from the compressor surface a soundmeasuring room.

(4)

Vibration level is measured on the compressor surface.

(5)Connection Type

BR : Brazing , RL : Rotalock , FL : Flange , FR : Flare

(6)Scope of Supply

- 1) Compressor Assembly Charged with Refrigerant Oil and Nitrogen Gas.
- 2) The companion connections shall be provided by others.

The other specifications

- 1. Hermetic terminal : 1/4"quick connect type
- 2. Space volume of inner shell : 2000 mL(DS1529V1•DS1834V1), 2690 mL(DS2244V1)
- 3. Motor Insulation grade : E
- 4. Approval voltage range rated voltage $\pm 10\%$
- 5. Starting performance
 - The minimum starting voltage shall be as TABLE 1. (see note 7) under the following conditions.
 - (1) The starting pressure should be between the suction and discharge of the compressor was balanced and adjusted as shown in the TABLE 1.
 - (2) The temperature of compressor case was adjusted to 20 °C or higher at the starting conditions.

TABLE 1

Starting conditions Motor temperature	Ambient temp.	Pressure	Minimum starting voltage { V2 }
Cold-starting Cold state (Room temperature)	20 °C	1.35 MPa	85% of rated voltage
Hot-starting<Standard> Hot state after operated under standard condition	32.2 °C	1.29 MPa	85% of rated voltage
Hot-Starting<Overload> Hot state after operated overload condition.	43 °C	1.42 MPa	90% of rated voltage

[note 7]

The starting voltage (V2) is measured by Hitachi starting test apparatus. It means the accelerable minimum voltage by the accelerating torque between the motor starting torque and the stalling torque, and it is different with the continuous operable voltage (V4) after the reach of maximum speed of motor. (see fig 1)
As the starting voltage of the product depend on the structure and design of the product, you should measure the starting voltage of the product and you should confirm it is no problem.

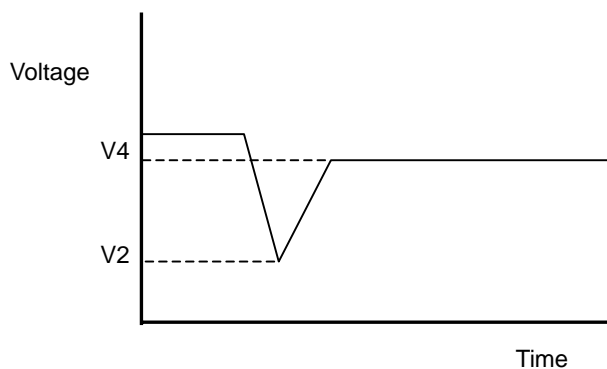

Fig 1

2. PARTS AND DRAWING LIST

No.	Item	Q'ty/Compressor				Drawing No.	Remarks	SUPPLY
		DS1529V1	DS1834V1	DS2244V1				
1	Dimension sketch	X	X	-		BB0000659		-
2	Dimension sketch	-	-	X		BB0000660		-
3	Wiring diagram	X	X	X		BB0000658		-
4	Connecting sketch of accumulator	X	X	-		3CYCA6121		-
5	Connecting sketch of accumulator	-	-	X		BB0000576		-
6	Refrigeration system	X	X	-		3CYCA6131		-
7	Refrigeration system	-	-	X		BB0000793		-
OVER LOAD PROTECTOR		X	X	X		-	Internal OLR	YES
Mounting parts	RUBBER GROMMET	4	4	4		3CYC62866		YES
	PIPE	4	4	4		4CYC11219	3PFHA5981A	YES
	WASHER	4	4	4		4CYC11220	3SPAA5982A	YES
Terminal and cover	HERM-COVER	1	1	1		3CYCA4998	2TRR62549A	YES
	RUBBER PLATE	1	1	1		3CYCA4999	3TKEA5983A	YES
	NUT	1	1	1		3CYC62897	3SMGA5984A	YES
	BUSH	1	1	1			3TVBA5907A	YES
Earth parts	CROSS RECESSED HEAD SCREW	1	1	1		4CYC11207	40+10NAA2	NO
	TOOTHED LOCK WASHER	1	1	1		4CYC11206	40BARWAA2	NO
Electrical parts	THERMAL OVERLOAD RELAY	1	1	1		BB0004663		YES
	PLUGGING RELAY	1	1	1		-		NO
Cycle parts	CAPILLARY FOR REQUID INJECTION (Note 8)	1	1	1		3CYCA2072 (13.3kPa)	Required for operation	YES
	ACCUMULATOR	2	2	-		3CYCA5055	2PDP62110A valid volume 1060mL (530mL x 2)	YES
	ACCUMULATOR	-	-	1		BB0000577	Valid volume 2300mL	YES
	STRAINER	-	-	1		BB0004668	BB0001687A	YES

[note 8]

The recommended resistance value for the injection capillary is the result of the matching trial using our calorimeter. Since proper capillary specification will depend on refrigeration cycle, please conduct a matching test installed in your product subject to the following conditions.

- (1) To satisfy the over load coil temperature: 115°C or lower. (preferably about 100°C max)
- (2) To apply the Injection capillary resistance value considering the appropriate amount of injection resulting in the best performance in the cooling capacity and input value.

3. APPLICATION RANGE

1. Scope

This specification is applied to HITACHI scroll compressor.

2. Common specification of compressor

2.1 Appearance

The surface of compressor shall be painted black and has no cracks, dents, peeling, or significant rust.

2.2 Marking

Model name and production date should be shown on the surface of compressor. The compressor containing refrigeration oil and dried N₂ gas has one white circle mark and one yellow circle mark.

2.3 Insulation distances

The Electrical Appliance and Material Safety Law (JAPAN) and JIS C9621 are applied.

2.4 Insulation resistance

Measurement should be above 10 MΩ between charged parts and non-charged parts by 500 V insulation resistance meter at normal temperature and normal humidity.

2.5 Dielectric Withstand Voltage Test

After 2.4 test, 1500 V A/C 50 Hz or 60 Hz is applied between live parts and dead metal parts continuously for one minute by gradual rise of voltage. In case of 1800 V, duration is one second instead of one minute.

2.6 Pressure Test

Pressure test should be done by JIS B8620 and UL984.

2.7 Dryness

Residual water content is below 0.18mL by the cold trap method described below:

Table 2. Cold trap method

Item	condition
Furnace	146 ± 3 °C
Pre-heat hour	No pre-heat
Hour of taking water (Preheating time excluded)	6 hours
Degree of vacuum (Continuous vacuum)	Below 133 Pa
Solvent for cold bath	Methanol
Coolant for cold bath	Dry ice

2.8 Cleanliness

Drain the refrigerant oil. Pour washing liquid into the compressor. Lay down and roll the compressor and drain washing liquid. Filtrate by filter paper. The trapped particles should be under 70 mg.

2.9 Airtight test pressure

3.24 MPa

3. System design limitations

3.1 Observance of the specification

The compressor should always be operated under the condition set forth in this specification and it should not be operated under any other specifications. Accessories should also be used as specified. In addition, the specified parts should be used during servicing. Fuse or circuit breaker should be connected to main

electric circuit.

3.2 Power source voltage

Voltage applied to the hermetic terminal should be within the range mentioned in this specification.

In the case of 3 phases electric power source, the unequilibrium of the voltage between each phase must be used within 3%.

$$\text{Unequilibrium} = \frac{\text{Max.deviation voltage} - \text{Ave.voltage}}{\text{Average voltage}} \times 100(\%)$$

Furthermore, in the case of 3 phases electric power source, the wiring for reverse rotating

caused by two phases replacement must not be used. The damage of the compressor caused by the reverse rotating is out of warranty. If wiring may cause reverse rotating, the direction relay listed on the list of equipment and materials must be connected.

3.3 Operating temperatures and pressures

Suction pressure and discharge pressure should be within the range of FIG.4, 5. (page 16, 17)

The difference between discharge pressure and suction pressure must be more than the pressure of table 3.

TABLE 3

Model	DS1529V1, DS1834V1	DS2244V1
Discharge pressure - Suction pressure (MPa)	0.61	0.69

The operating temperatures and pressures of a compressor should be within the range shown in the following TABLE4.

TABLE 4

Item	Standard load condition	Overload condition	Blocked fan condition
Discharge pressure (MPa)	1.811	2.87	4.22 MAX
Suction pressure (MPa)	0.202	0.513	
Compressor case bottom temp.	99°C or below and 6 degrees higher than condensing temperature.		
Motor winding temp. (measured by the resistance method)	Rated voltage; 105 °C MAX Rated voltage ± 10%; 115 °C MAX	Rated voltage ± 7.5%; 115 °C MAX	Under stable condition; 165 °C MAX (average) 190 °C MAX (highest)
Suction pipe temp.	Higher than outlet pipe of evaporator		
Discharge pipe temp.	Lower than 110 °C at 300 mm away from compressor surface.		
Ambient temp.	32.2 °C	43 °C	32.2 °C

[note 9]

Overload condition should not be continuous.

[note 10]

The end of thermocouple should be soldered on the discharge pipe surface, and the soldered place is covered by urethane foam insulation preventing the influence of airflow, when you measure the discharge pipe temperature.

3.4 Compressor ambient temperature

The compressor should be operated within the ambient temperature range that satisfies the motor winding temperature requirements shown previously Section 3.3. This compressor should be used in the place that the ambient temperature is above $-10\text{ }^{\circ}\text{C}$. Please confirm the starting of compressor, when the temperature of compressor surface is $-10\text{ }^{\circ}\text{C}$.

Under $-10\text{ }^{\circ}\text{C}$ ambient temperature, in the case that the temperature of compressor surface is above $-10\text{ }^{\circ}\text{C}$ by the crankcase beating etc, you can use the compressor if the starting is possible.

3.5 Operating and Shut-off interval

The compressor should not be started/stopped more than 6 times per hour. The compressor should be operated continuously at least for 5 minutes after being turned on. Allow a minimum of 3 minutes shut-off time before restarting.

Compressor should be started on the condition that pressure status of high/low pressure sides is balanced.

3.6 Oil back and oil level of compressor

Oil should be returned continuously to the compressor and not kept in the refrigerating system.

Oil level of compressor should be higher than 10 mm from the lubricating piece fixed on the end of the crankshaft. Compressor must not be started operated under a dual-layer separate status. In case of foaming situation, the height of this foam does not mean the height of the oil level. If you don't keep the oil level, the oil shortage will occur, and influence the reliability of compressor.

(Please check the oil level by the compressor with sight glass we supply.)

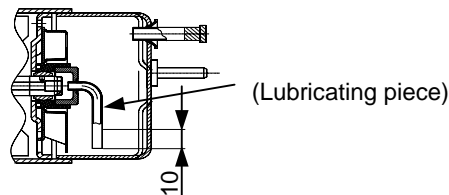

3.7 Accumulator

The Accumulator should be valid volume above the valid volume of the accumulator of our company specification.

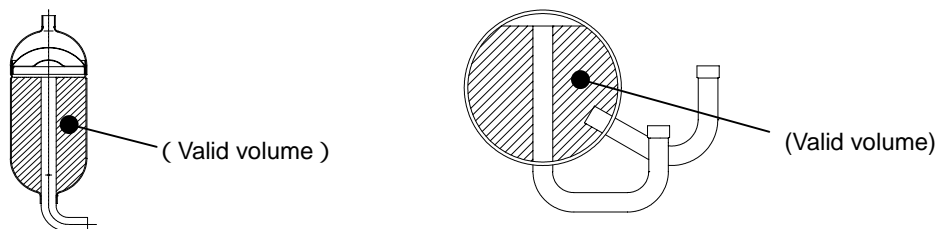

3.8 Liquid refrigerant back

Liquid level in the accumulator should be maintained lower than top of suction pipe in the accumulator. (see fig 2)

(Please check the liquid level by the accumulator with sight glass we supply.)

When knocking noise, current increase and undesirable vibration are caused, another accumulator should

be equipped to the compressor and/or refrigerant charge should be reduced to prevent liquid refrigerant flood back.

Liquid refrigerant should not flood back to the compressor under all conditions in the system.

There should be superheated gas returned to the compressor under all normal operating conditions.

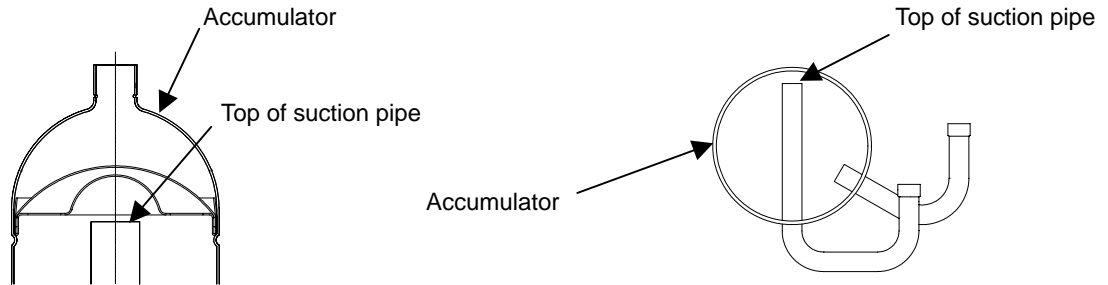

Fig 2

3.9 Strainer

A strainer must be equipped at a tube on suction side in case of using a accumulator without a strainer. (180 mesh)

3.10 Allowable incline

Compressor should be operating in the horizontal rotating shaft. But the inclination of shaft is within 3 deg in every direction. In case of the hermetic terminal side in the shaft direction is higher than horizontal, it should be kept up to 5 deg.

3.11 Pipe vibration

The displacement of the pipes, which connect from the compressor to other parts of the refrigeration systems, should be less than 0.8 mm (1/32") when the compressor is operating at rated frequency +10 / -10 and voltage range of rate ± 10%.

Displacement in excess of 0.8 mm (1/32") will require changing tube length and/or routing.

3.12 Connecting tube design

in designing and routing tubing that connects the compressor to the other parts of the air conditioner, the following should be considered.

Moving tubes to the moving parts;
 minimum clearance 12.7 mm (1/2")

Moving tubes to non-moving parts ;
 minimum clearance 9.5 mm (3/8")

Moving tubes never touch the electrical lead wires.

3.13 Dust of hermetic terminal

Hermetic terminal area should be covered with the electrical cover by the designated method to prevent the entering of dust.

3.14 Rotation direction of compressor

Connect compressor terminals as specified in circuit diagram. Reverse operation will result pump breakdown.

3.15 Internal over load protector (OLR).

Although an OLR that Hitachi selected is installed in this compressor, the current and temperature may not be appropriated for the structure or design of the unit in which the compressor will be mounted. Unit-mounting matching tests should therefore be conducted and checks should be performed to ensure that the requirements listed as item (1) and (2) below are satisfied.

If the OLR could not satisfy the requirements in the unit test, this should be notified to Hitachi and then after reselection through mutual discussions on the optimum OLR for the unit, unit-mounting test should be performed again.

(1) OLR non-operating test:

The provisions of section 3.3 should be satisfied.

(2) OLR operating test (trouble-assuming test):

When the compressor ambient temperature is 23 ± 2 °C, the winding temperature should not exceed 190 °C at rated voltage $\pm 6\%$, and when the compressor ambient temperature is 0 ± 2 °C, the winding temperature should not exceed 240 °C at rated voltage -15% , and when the compressor ambient temperature is 40 ± 2 °C.

Supplementary description;

[1] Exception for the value in transitional states.

[2] The motor winding temperature should be measured using the resistance method.

[3] The tests should be terminated when the total number of OLR operations or the total OLR operating time reaches 10,000 (time) or 15 days, which ever comes first.

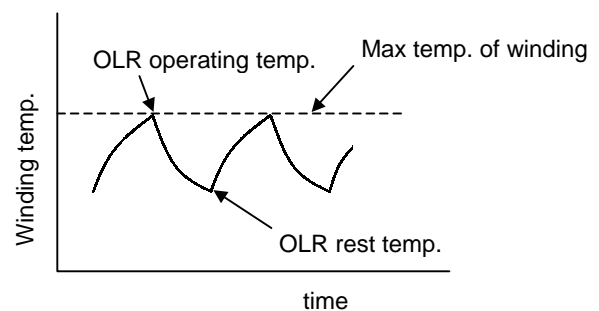

Fig 3

4. Process limitations

4.1 The degree of vacuum in the refrigerating system should be less than 133 Pa(abs) at room temperature just before charging refrigerant. The quantity of water should be less than 0.2 g.

The quantity of water the cycle in operation is to make to the 40 ppm following in the refrigerating cycle by using the suitable dryer that does not contain ACTIVATED ALUMINA.

4.2 The structure of cycle constitution or drier should be done so that the powder of the drying material does not come out throughout the cycle.

4.3 The weight of foreign particles on the inside surface of the heat exchange tubes should be less than 0.05 g/m^2 . This value means the weight of foreign particles filtered after washing inside surface of the heat exchange tubes with alkali.

Metallic dust should not be permitted to enter the refrigerating system.

4.4 Eliminate all system contaminates such as trichloroethane, alkalis, soaps, acids, oil and washing fluid used in machining the heat exchanger.

4.5 Always purge the compressor with dry nitrogen during assembly of the system .

4.6 The quantity and kind of contamination (the process materials) in the cycle should be grasped and managed. Carry on reliability test that Input contamination a lot than anticipated contamination quantity.

4.7 The motor winding temperatures should be less than 149 °C in process of manufacturing the refrigerating system. The temperature of the hermetic terminal body should be less than 177 °C.

4.8 The compressor should be operated for more than 20 seconds within 15 minutes after refrigerant is put into the system so that proper lubrication of the pump can occur.

5. Miscellaneous

5.1 The pipe and hermetic pins, which are attached to the compressor, should not be bent.

5.2 The compressor should never be operated while under vacuum; otherwise, internal arcing can damage parts.

5.3 The compressor should not be operated in a method that forms a vacuum and absorbs air.

5.4 The compressor should not be left open to the atmosphere for more than 15 minutes.

5.5 The electric pulse should not be applied to the hermetic terminals when the compressor is under vacuum.

5.6 The compressor should be kept in a clean place with low-moisture.

5.7 The compressor must not be applied for transportation equipment such as automobiles, trains, ships, and the others.

5.8 The compressor should not be splashed intentionally with water.

5.9 Refrigerant should be charged from the condenser end of the refrigeration system. Never charge refrigerant to the compressor directly.

5.10 Temperatures within systems during stable compressor operation should not be less than -45 °C to prevent wax precipitation from the oil.

5.11 The compressor, if dropped, should not be used.

5.12 Compressor mounting

Rubber grommets are designed soft to provide noise isolation and to lessen vibration energy transmission. Stud bolt should be designed to provide sufficient clearance for noise and vibration isolation and to prevent compressor from coming off its mount.

5.13 The first starting voltage supplied to the refrigerating system should be more than the starting voltage mentioned TABLE 1. (page 4)

Because the viscosity of the oil may be high at first starting until the refrigerant dissolves in the oil.

5.14 The compressor should be kept out of a corrosive atmosphere, such as a chemicals storage area.

5.15 The lead wires should be connected to the hermetic terminals without touching the surface of the compressor.

5.16 There should be adequate clearance between the OD23-under-surface of push-nut and the upper surface of rubber grommets.

5.17 The compressor should be used within one year of receipt.

5.18 The failure of refrigeration system components such as the reversing valve, solenoid valve, defrost mechanism, refrigerant control parts, fan motor, etc. may cause failure of the compressor. Reliability of those components should be checked.

4. PERFORMANCE DATA

Model : DS1529V1

Refrigerant	R404A
Power Supply	3PH/400V/50Hz
Sub Cooling	0 K
Return Gas Temp.	18
Cooling	Fan Cooling+Liquid Injection

Cooling capacity[W]

Condensing Temp.	Power Supply	Evaporating Temp.											
		-45	-40	-35	-30	-25	-20	-15	-10	-5	0	5	10
35	400V-50Hz	765	965	1,222	1,535	1,904	2,330	2,812	3,350	3,944	4,594	5,301	6,064
40	400V-50Hz	711	893	1,129	1,418	1,762	2,160	2,612	3,118	3,679	4,293	4,961	5,683
45	400V-50Hz	658	821	1,035	1,302	1,620	1,991	2,413	2,887	3,413	3,991	4,621	5,303
50	400V-50Hz	597	746	942	1,186	1,478	1,816	2,203	2,637	3,118	3,647	4,223	4,847
55	400V-50Hz	536	671	849	1,071	1,335	1,642	1,992	2,386	2,822	3,302	3,825	4,391

Motor Input[W]

Condensing Temp.	Power Supply	Evaporating Temp.											
		-45	-40	-35	-30	-25	-20	-15	-10	-5	0	5	10
35	400V-50Hz	984	1,020	1,055	1,090	1,126	1,161	1,196	1,232	1,267	1,303	1,338	1,373
40	400V-50Hz	1,078	1,114	1,150	1,186	1,222	1,258	1,294	1,330	1,366	1,402	1,438	1,474
45	400V-50Hz	1,172	1,209	1,245	1,282	1,319	1,355	1,392	1,429	1,465	1,502	1,538	1,575
50	400V-50Hz	1,295	1,333	1,370	1,408	1,445	1,483	1,521	1,558	1,596	1,633	1,671	1,708
55	400V-50Hz	1,418	1,457	1,495	1,534	1,572	1,611	1,649	1,688	1,726	1,765	1,803	1,841

Current[A]

Condensing Temp.	Power Supply	Evaporating Temp.											
		-45	-40	-35	-30	-25	-20	-15	-10	-5	0	5	10
35	400V-50Hz	2.2	2.2	2.3	2.3	2.4	2.4	2.4	2.5	2.5	2.5	2.6	2.6
40	400V-50Hz	2.3	2.3	2.4	2.4	2.5	2.5	2.5	2.6	2.6	2.6	2.7	2.7
45	400V-50Hz	2.4	2.4	2.5	2.5	2.6	2.6	2.6	2.7	2.7	2.8	2.8	2.9
50	400V-50Hz	2.5	2.6	2.6	2.7	2.7	2.8	2.8	2.8	2.9	2.9	3.0	3.0
55	400V-50Hz	2.7	2.7	2.8	2.8	2.9	2.9	2.9	3.0	3.0	3.1	3.1	3.2

Model : DS1834V1

Refrigerant	R404A
Power Supply	3PH/400V/50Hz
Sub Cooling	0 K
Return Gas Temp.	18
Cooling	Fan Cooling+Liquid Injection

Cooling capacity[W]

Condensing Temp.	Power Supply	Evaporating Temp.											
		-45	-40	-35	-30	-25	-20	-15	-10	-5	0	5	10
35	400V-50Hz	889	1,118	1,413	1,774	2,201	2,693	3,251	3,875	4,565	5,321	6,142	7,030
40	400V-50Hz	824	1,035	1,309	1,643	2,040	2,498	3,017	3,598	4,241	4,945	5,711	6,538
45	400V-50Hz	759	953	1,204	1,513	1,879	2,303	2,783	3,321	3,917	4,569	5,279	6,046
50	400V-50Hz	681	861	1,092	1,376	1,711	2,099	2,538	3,030	3,574	4,170	4,818	5,518
55	400V-50Hz	604	769	980	1,238	1,543	1,895	2,293	2,739	3,231	3,770	4,356	4,989

Motor Input[W]

Condensing Temp.	Power Supply	Evaporating Temp.											
		-45	-40	-35	-30	-25	-20	-15	-10	-5	0	5	10
35	400V-50Hz	1,112	1,153	1,195	1,236	1,277	1,319	1,360	1,402	1,443	1,485	1,526	1,568
40	400V-50Hz	1,231	1,273	1,315	1,357	1,398	1,440	1,482	1,524	1,566	1,607	1,649	1,691
45	400V-50Hz	1,351	1,393	1,435	1,477	1,519	1,562	1,604	1,646	1,688	1,730	1,772	1,814
50	400V-50Hz	1,525	1,564	1,603	1,642	1,681	1,720	1,759	1,798	1,837	1,876	1,915	1,954
55	400V-50Hz	1,699	1,735	1,771	1,807	1,843	1,879	1,915	1,951	1,987	2,023	2,059	2,095

Current[A]

Condensing Temp.	Power Supply	Evaporating Temp.											
		-45	-40	-35	-30	-25	-20	-15	-10	-5	0	5	10
35	400V-50Hz	2.3	2.4	2.4	2.5	2.5	2.6	2.6	2.7	2.7	2.8	2.8	2.8
40	400V-50Hz	2.5	2.5	2.6	2.6	2.7	2.7	2.8	2.8	2.9	2.9	3.0	3.0
45	400V-50Hz	2.6	2.6	2.7	2.8	2.8	2.9	2.9	3.0	3.0	3.1	3.1	3.2
50	400V-50Hz	2.8	2.9	2.9	3.0	3.0	3.1	3.1	3.1	3.2	3.2	3.3	3.3
55	400V-50Hz	3.0	3.1	3.1	3.2	3.2	3.2	3.3	3.3	3.4	3.4	3.5	3.5

Model : DS2244V1

Refrigerant	R404A
Power Supply	3PH/400V/50Hz
Sub Cooling	0 K
Return Gas Temp.	18
Cooling	Fan Cooling+Liquid Injection

Cooling capacity[W]

Condensing Temp.	Power Supply	Evaporating Temp.											
		-45	-40	-35	-30	-25	-20	-15	-10	-5	0	5	10
35	400V-50Hz	1,121	1,409	1,780	2,233	2,768	3,386	4,087	4,869	5,735	6,683	7,713	8,826
40	400V-50Hz	1,028	1,301	1,648	2,070	2,566	3,136	3,780	4,499	5,292	6,159	7,100	8,116
45	400V-50Hz	935	1,193	1,517	1,907	2,363	2,885	3,473	4,128	4,848	5,635	6,487	7,406
50	400V-50Hz	808	1,057	1,364	1,731	2,158	2,643	3,188	3,793	4,457	5,180	5,962	6,804
55	400V-50Hz	681	920	1,211	1,555	1,952	2,401	2,903	3,458	4,065	4,725	5,437	6,202

Motor Input[W]

Condensing Temp.	Power Supply	Evaporating Temp.											
		-45	-40	-35	-30	-25	-20	-15	-10	-5	0	5	10
35	400V-50Hz	1,391	1,442	1,493	1,544	1,595	1,646	1,697	1,748	1,799	1,850	1,901	1,952
40	400V-50Hz	1,559	1,610	1,661	1,712	1,763	1,814	1,865	1,916	1,967	2,018	2,068	2,119
45	400V-50Hz	1,727	1,778	1,829	1,880	1,931	1,981	2,032	2,083	2,134	2,185	2,236	2,287
50	400V-50Hz	1,933	1,987	2,040	2,094	2,148	2,201	2,255	2,308	2,362	2,416	2,469	2,523
55	400V-50Hz	2,139	2,196	2,252	2,308	2,365	2,421	2,477	2,533	2,590	2,646	2,702	2,758

Current[A]

Condensing Temp.	Power Supply	Evaporating Temp.											
		-45	-40	-35	-30	-25	-20	-15	-10	-5	0	5	10
35	400V-50Hz	2.9	3.0	3.0	3.1	3.2	3.2	3.3	3.3	3.4	3.5	3.5	3.6
40	400V-50Hz	3.1	3.2	3.2	3.3	3.3	3.4	3.5	3.5	3.6	3.6	3.7	3.8
45	400V-50Hz	3.3	3.3	3.4	3.5	3.5	3.6	3.6	3.7	3.8	3.8	3.9	4.0
50	400V-50Hz	3.5	3.6	3.7	3.7	3.8	3.9	3.9	4.0	4.1	4.1	4.2	4.3
55	400V-50Hz	3.8	3.8	3.9	4.0	4.1	4.1	4.2	4.3	4.4	4.4	4.5	4.6

5. RANGE OF USABLE PRESSURE

MODEL : DS1529V1 , DS1834V1

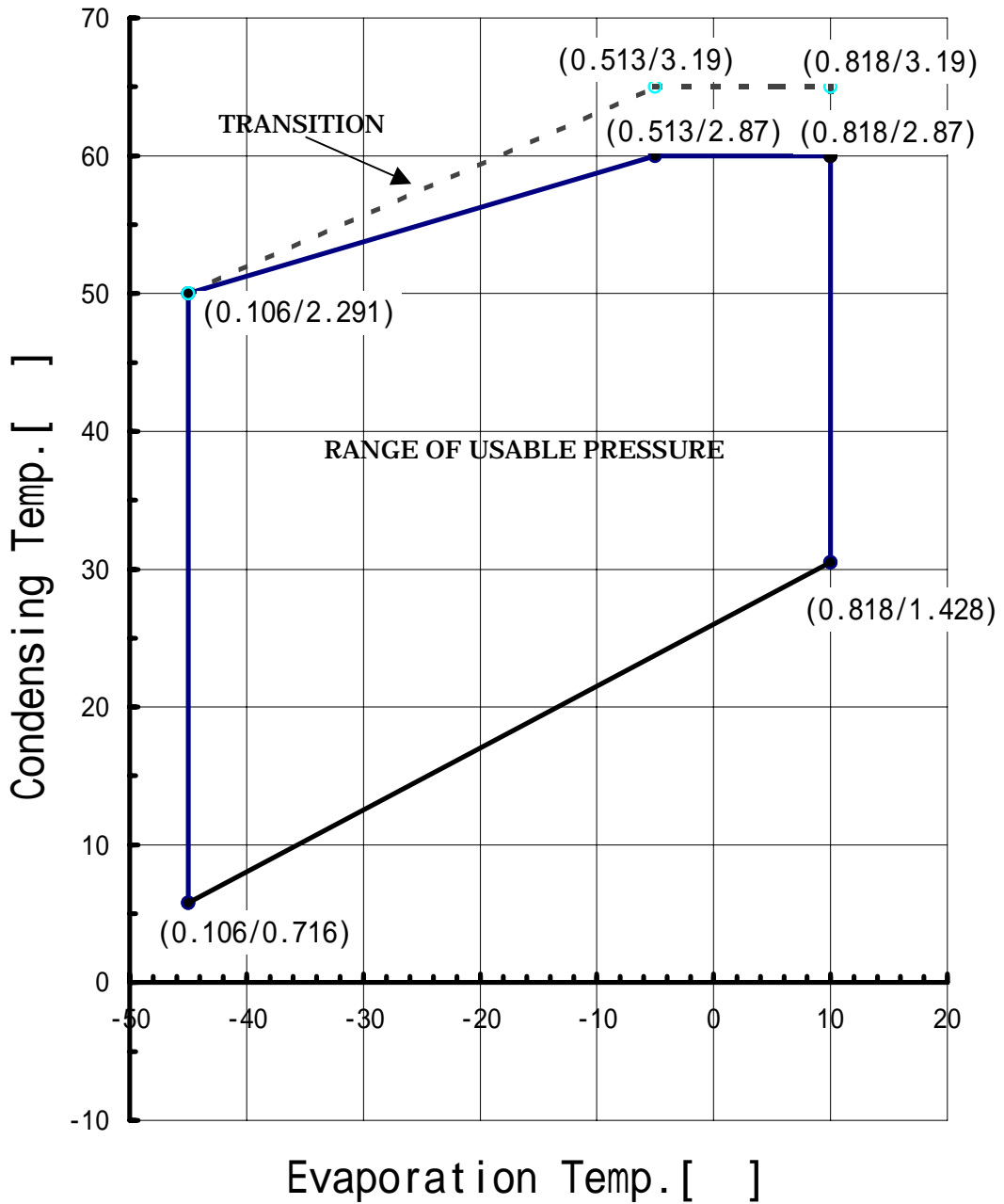

(Suction pressure / Discharge pressure [MPa])

Fig.4

MODEL : DS2244V1

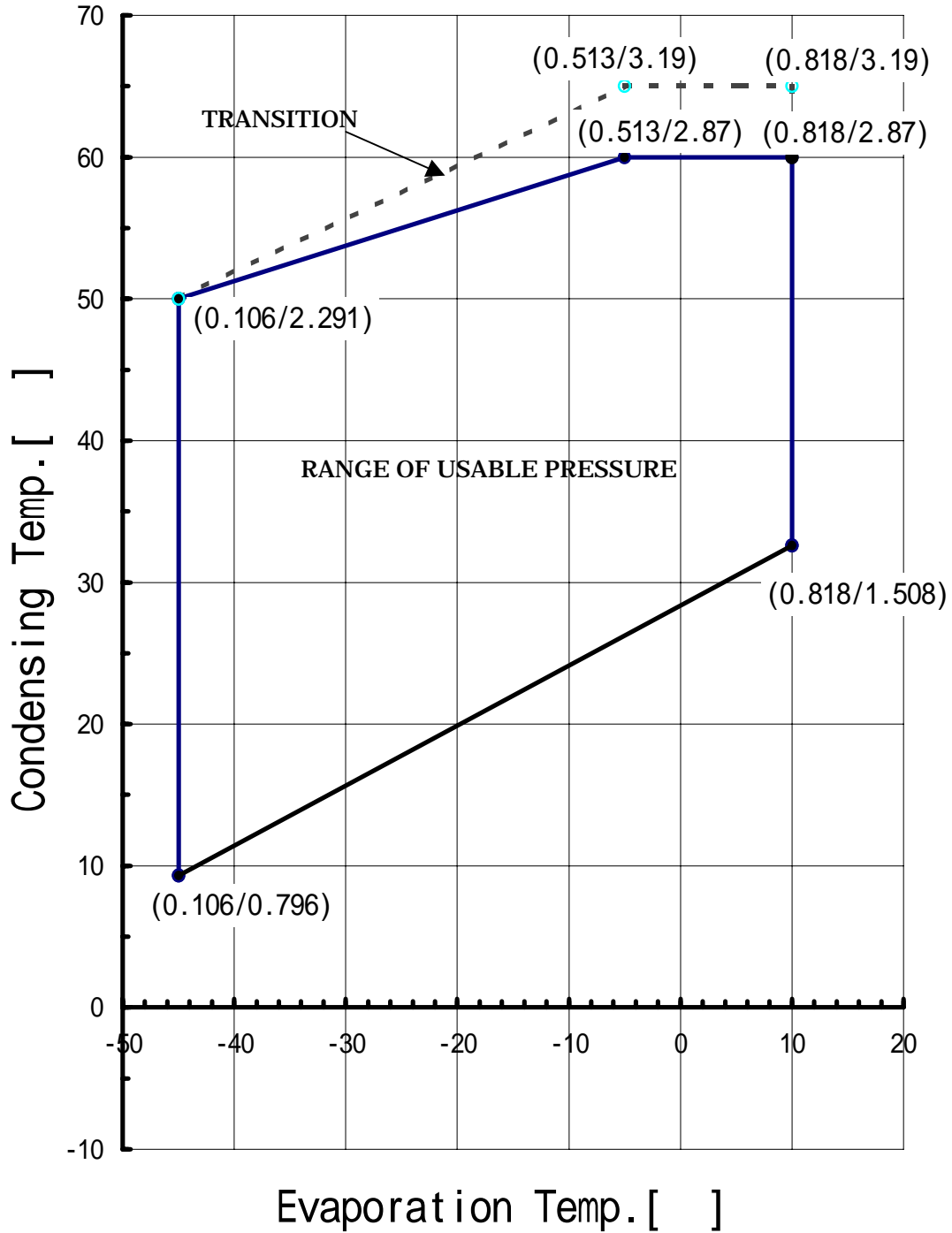

(Suction pressure / Discharge pressure [MPa])

Fig.5

The delivery of the performance test compressor

We deliver the compressor which did performance test regularly.
Quality of the performance test compressor is not problem as follows.
The compressor which did a performance test is the specification of a portion of a injection pipe. Please permit the mix delivery of the performance test compressor and the nomal compressor.

(Procedure after the performance test)

- 1.Removing the test pipe attached the suction and discharge pipe.
- 2.Cutting and Sealing up the test pipe attached the injection pipe.
- 3.Exchnging oil →Drying→Enclosing oil
- 4.Commercial test

(Portion of specification)

- 1.Cutting the injeciton pipe and covering the injection pipe with the test pipe.
- 2.Cutting and sealing up the copper test pipe

Injection pipe with copper pipe

*Cutting and sealing up the copper test pipe at 40mm

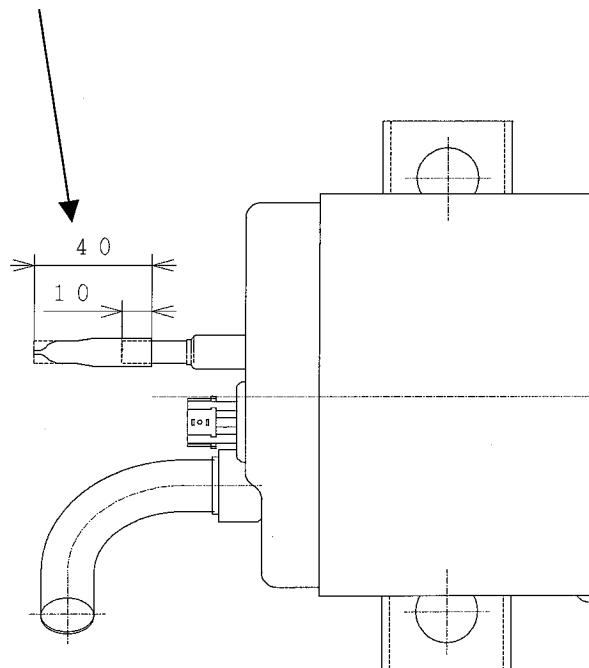

Supplement figure 1.

BB0000659

DS1529V1
DS1834V1
COMPRESSOR MODEL

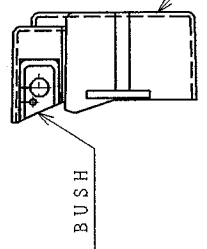

HERME-COVER
THE INSTALLATION WAY OF BUSH (VIEW B)

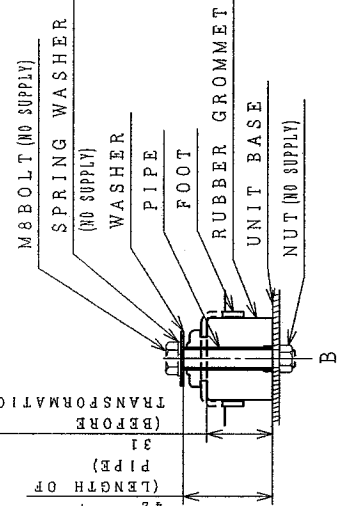
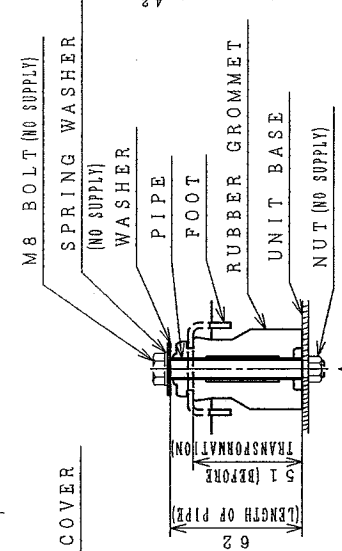
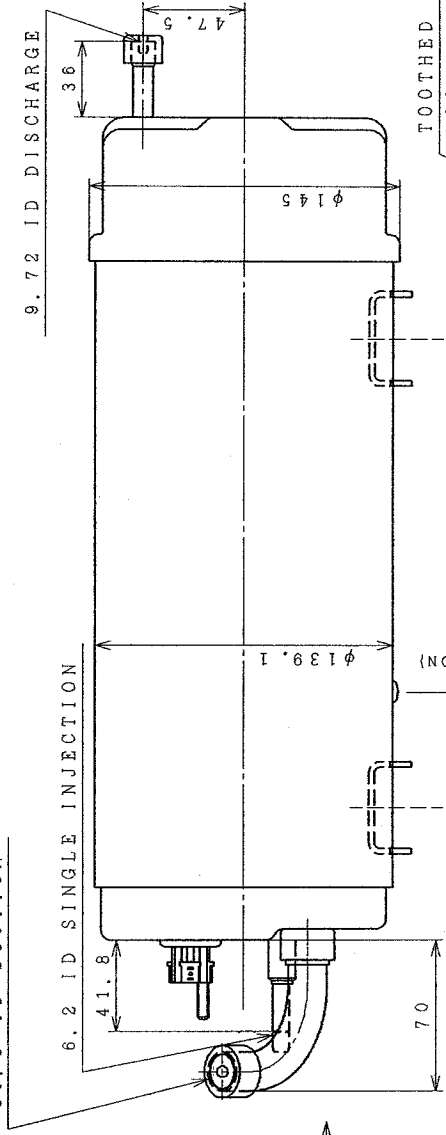
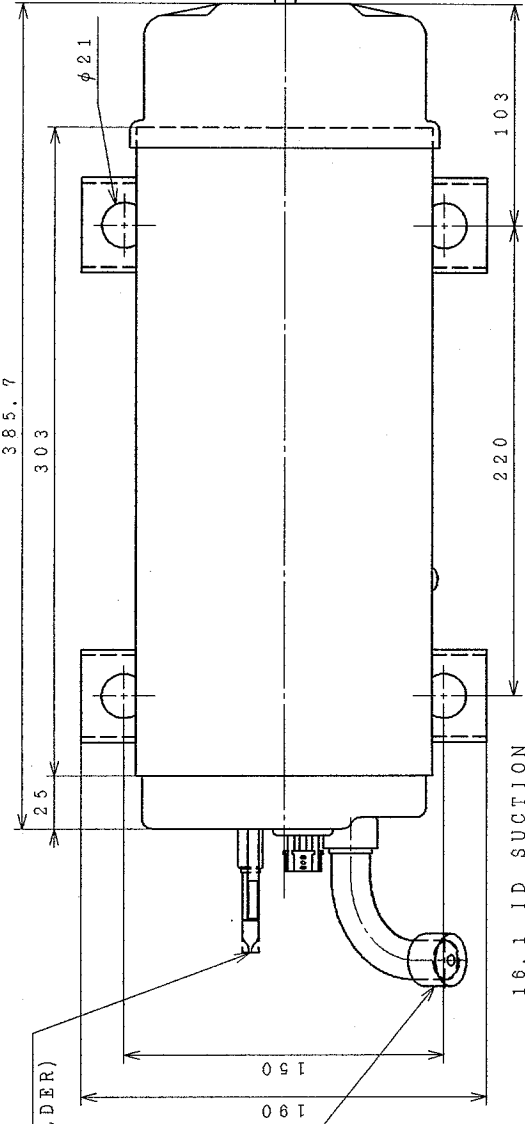
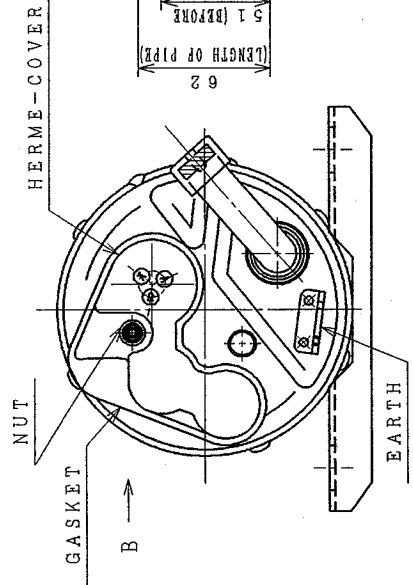
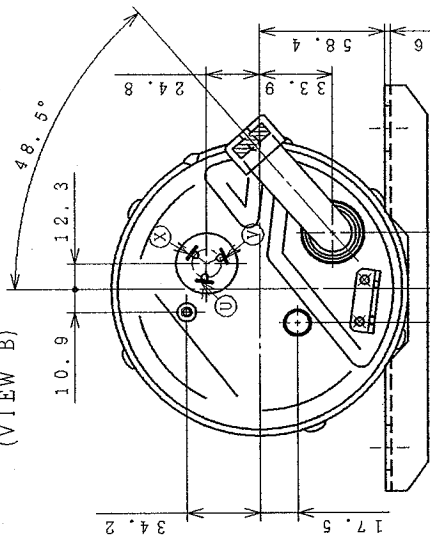

DIMENSION : mm

SIGNATURE	DATE	PROJECTION	SCALE	TITLE
DWN. W. SUZUKI	2005-07-18		1 : 1	COMPRESSOR DIMENSION SKETCH
CHKD. M. OBOUCHI	2005-07-18			
APPD. A. SIMEDA	2005-07-21			

MOUNTINGS (EITHER A OR B)

Hitachi Home & Life Solutions, Inc.
Tokyo Japan
3CYC BB0000659
TOCHIGI DWG. No.

REVISED 2005-07-22

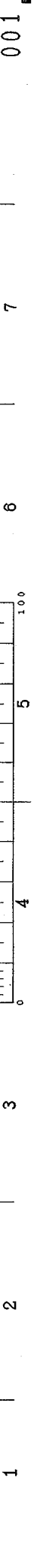

BB0000660

DS2244V1
COMPRESSOR MODEL

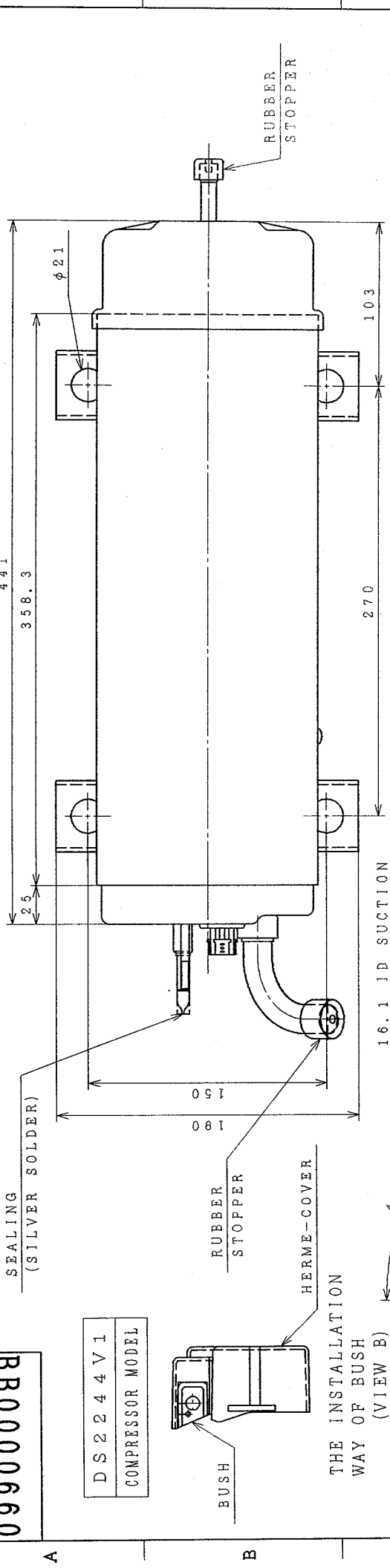

THE INSTALLATION WAY OF BUSH (VIEW B)

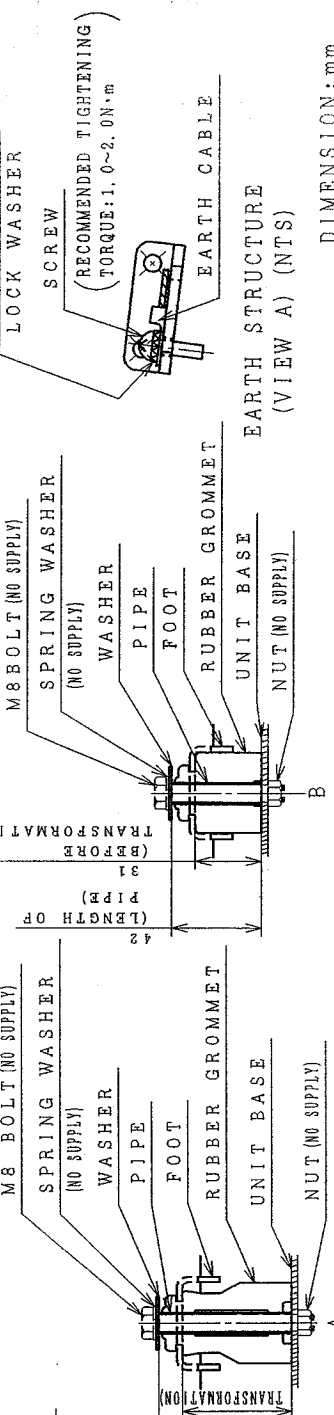
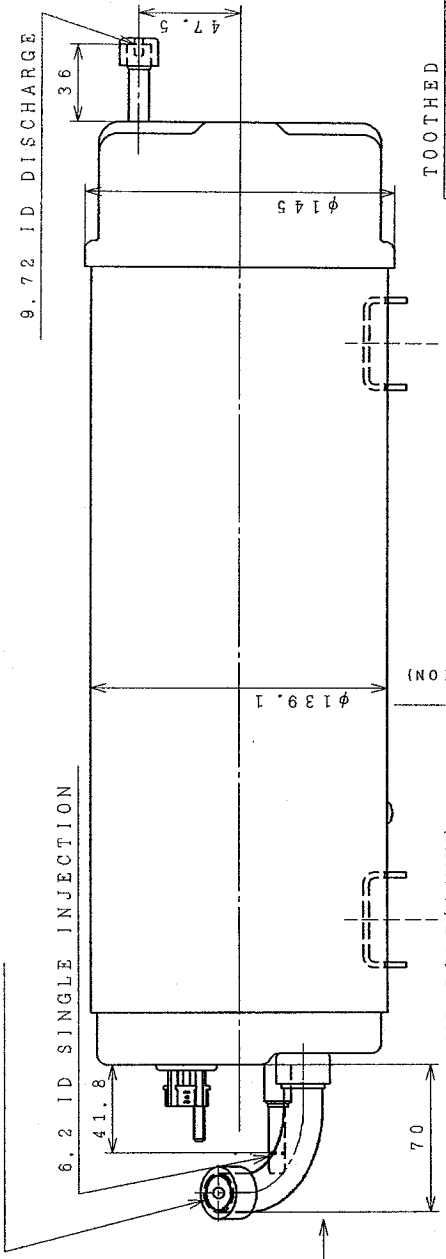
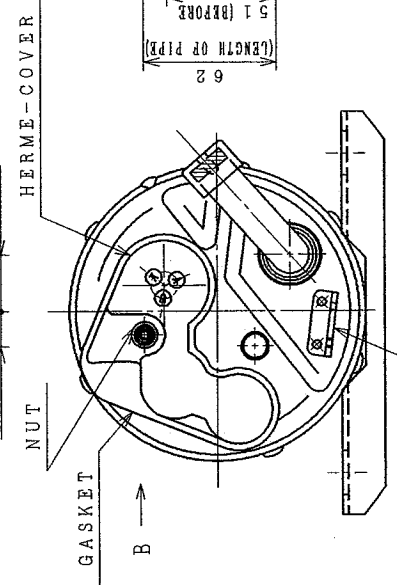
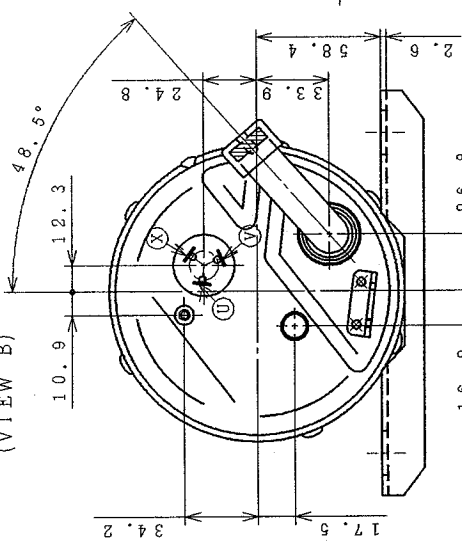
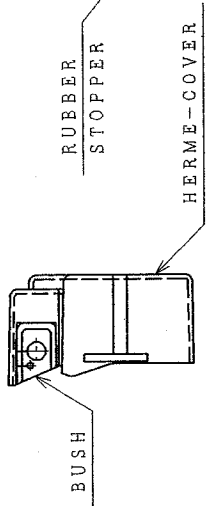

MOUNTINGS (EITHER A OR B)

SIGNATURE	DATE	PROJECTION	SCALE	TITLE
DWN. W. Sugawara	2005-07-18	1:1	1:1	COMPRESSOR DIMENSION SKETCH
CHKD. M. Oaeuchi	2005-07-18			
APPD. A. Simoda	2005-07-21			

Hitachi Home & Life Solutions, Inc. Tokyo Japan		TOCHIGI DWG. No.	3CYCBB0000660
REGD. 2005-07-22			

DIMENSION: mm

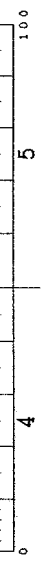

001

BB0000058

POWER SOURCE
3φ 400V 50Hz

WIRING DIAGRAM FOR SAMPLE COMPRESSOR

Electromagnetic Contactor
(Contactor) (Thermal Relay)

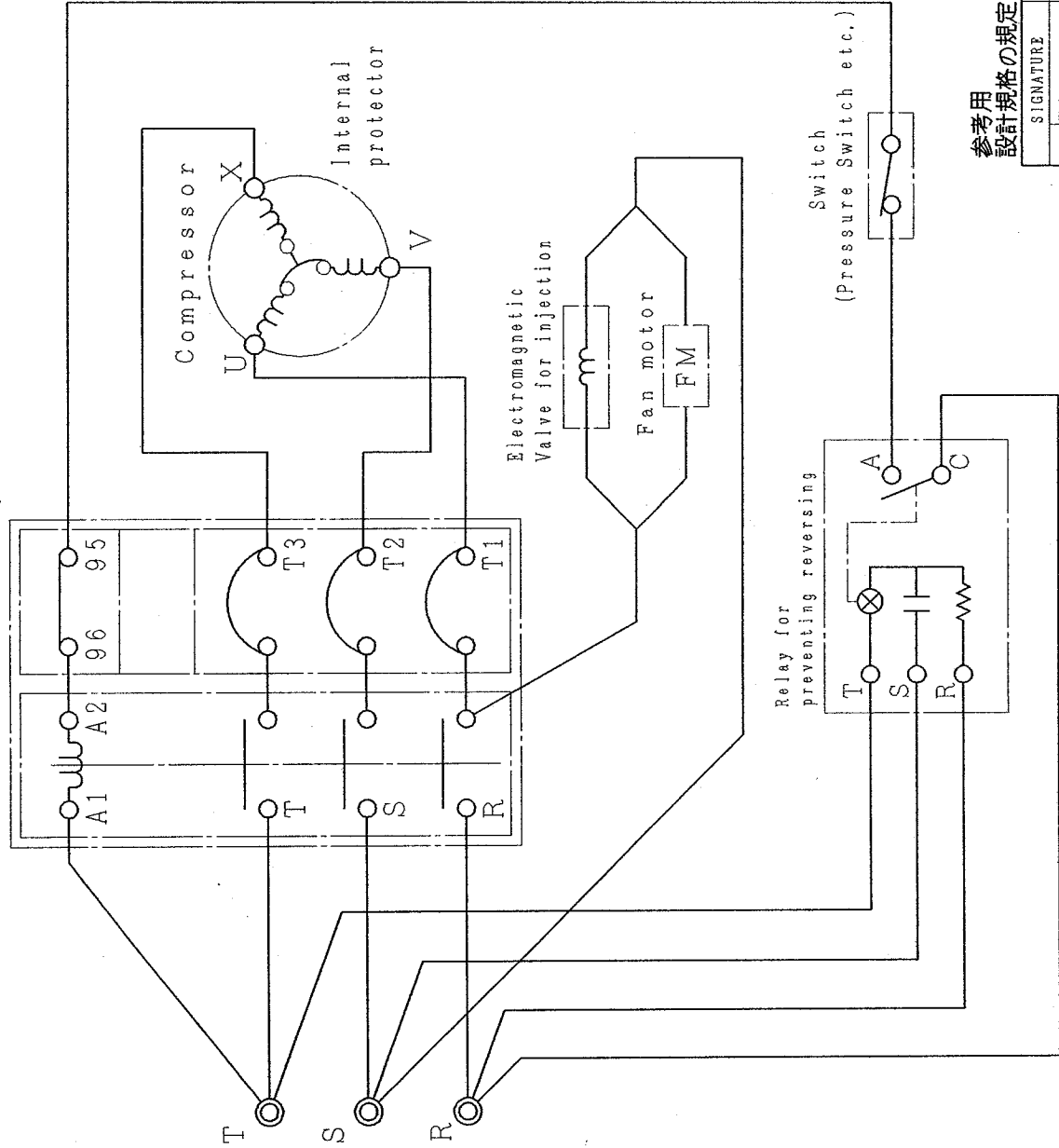

NOTES

1. Connect U, V, X in the same position of HERME-COVER marks.
2. Replace R phase with S phase in case of no running of compressor with this circuit (Leave T phase as it is).
3. This 'Wiring Diagram' is standard diagram recommended by Hitachi AP. However, the performance and reliability of each part or the combination should be sufficiently confirmed because the performance and reliability of each part can be affected by the surround environment and the attached condition.

参考用
設計規格の規定に従って取り扱うこと

SIGNATURE	DATE	PROJECTION	SCALE	TITLE
DWR. W. SUGIYAMA	2005-07-26	NTS	NTS	WIRING DIAGRAM
CHKD. M. ODOGUCHI	2005-07-26			
APPD. A. SIBADA	2005-07-26			

Hitachi Home & Life
Solutions, Inc.
Tokyo Japan

TOCHIGI DWG. No.

3CYC BB0000658

REGD
2005-08
01

1 2 3 4 5 6 7 100

002

3CYCA6121

The accumulator should be connected between discharge pipe of evaporator and suction pipe of compressor. The allowable incline should be less than 5° . The two accumulators should be connected in series like the figure.

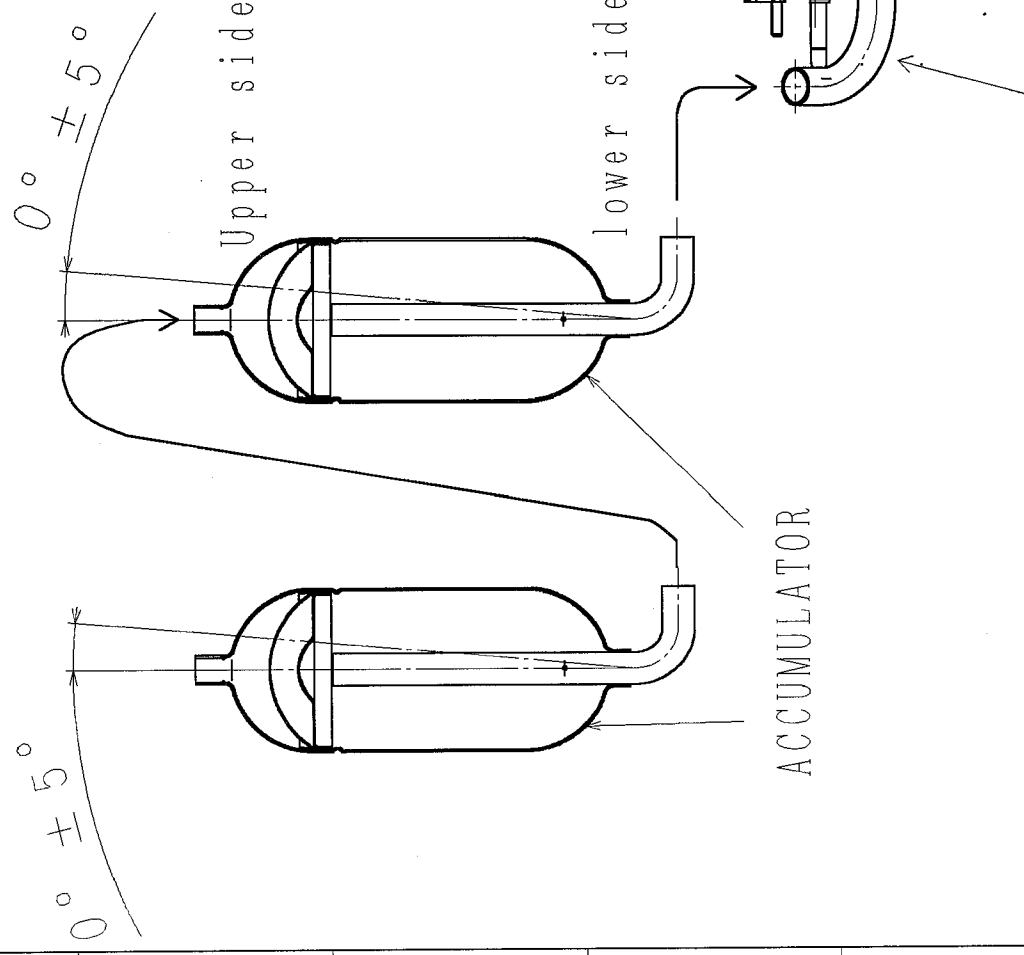

Suction pipe of compressor

SIGNATURE	DATE	PROJECTION	SCALE	TITLE
DWN. F. Nishioka	2004-05-26		1:2	CONNECTING SKETCH OF ACCUMULATOR
CHD. M. Unoquchi	2004-05-26			
APPD. S. Takawa	2004-05-26			

Hitachi Home & Life Solutions, Inc.
Tokyo Japan

TOCHIGI DWG. No. 3CYCA6121

REGD. 2004-05-27

CAD

1.00

0 1 2 3 4 5 6 7

001

BB0000576

The accumulator must be connected between discharge pipe of evaporator and suction pipe of compressor. The allowable incline should be less than 5°.

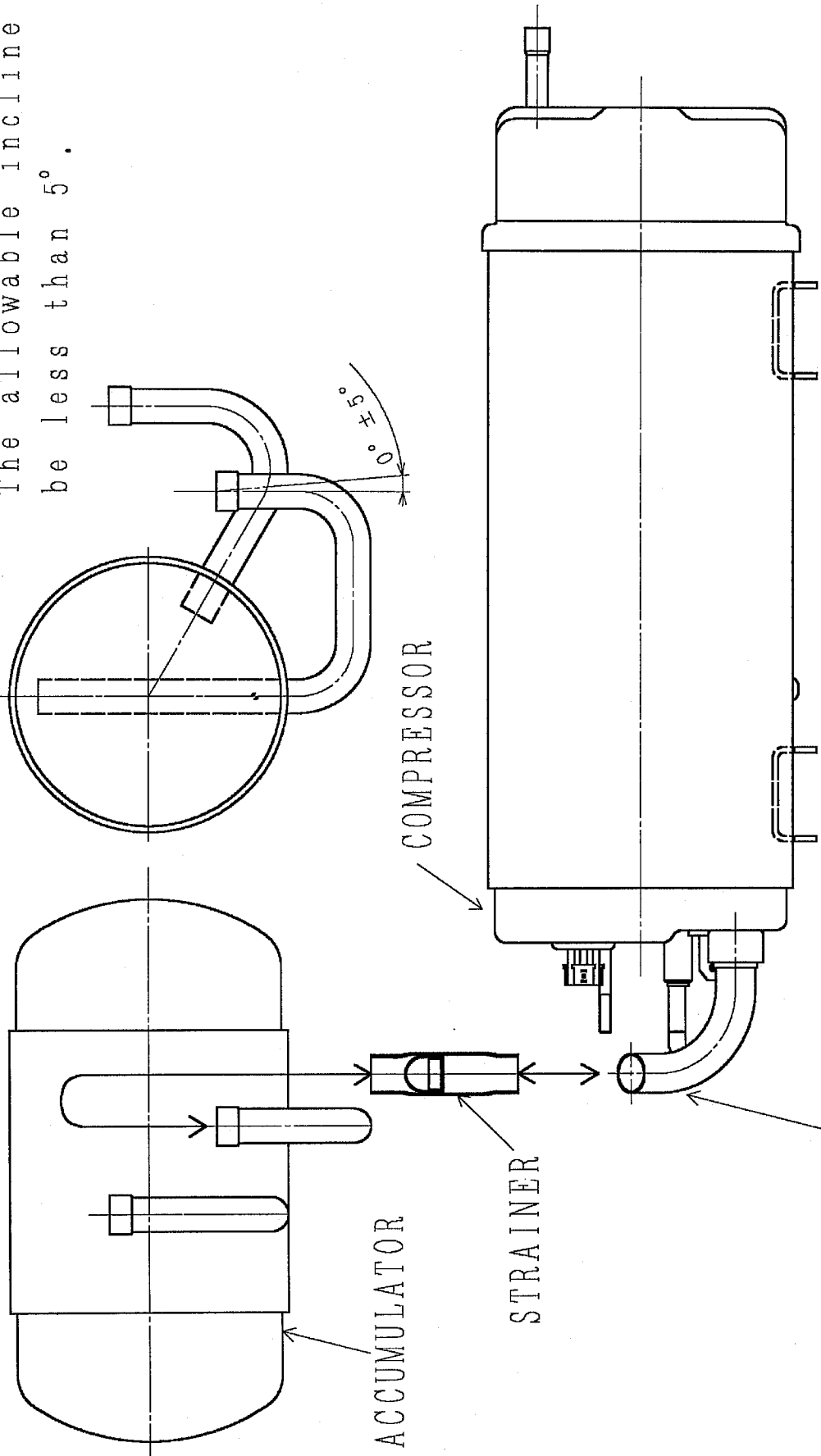

Suction pipe of compressor

SIGNATURE	DATE	PROJECTION	SCALE	TITLE
DWN. K. Mitsuoka	2005-07-04	①	1 : 2	CONNECTING SKETCH OF ACCUMULATOR
CHKD. M. Otaguchi	2005-07-04			TOCHIGI DWG. No.
APPD. A. Sineide	2005-07-04			Hitachi Home & Life Solutions, Inc. Tokyo Japan

RECD 2005-07-04

3CYCBB0000576

0 1 2 3 4 5 6 7 8

3CYCA6131

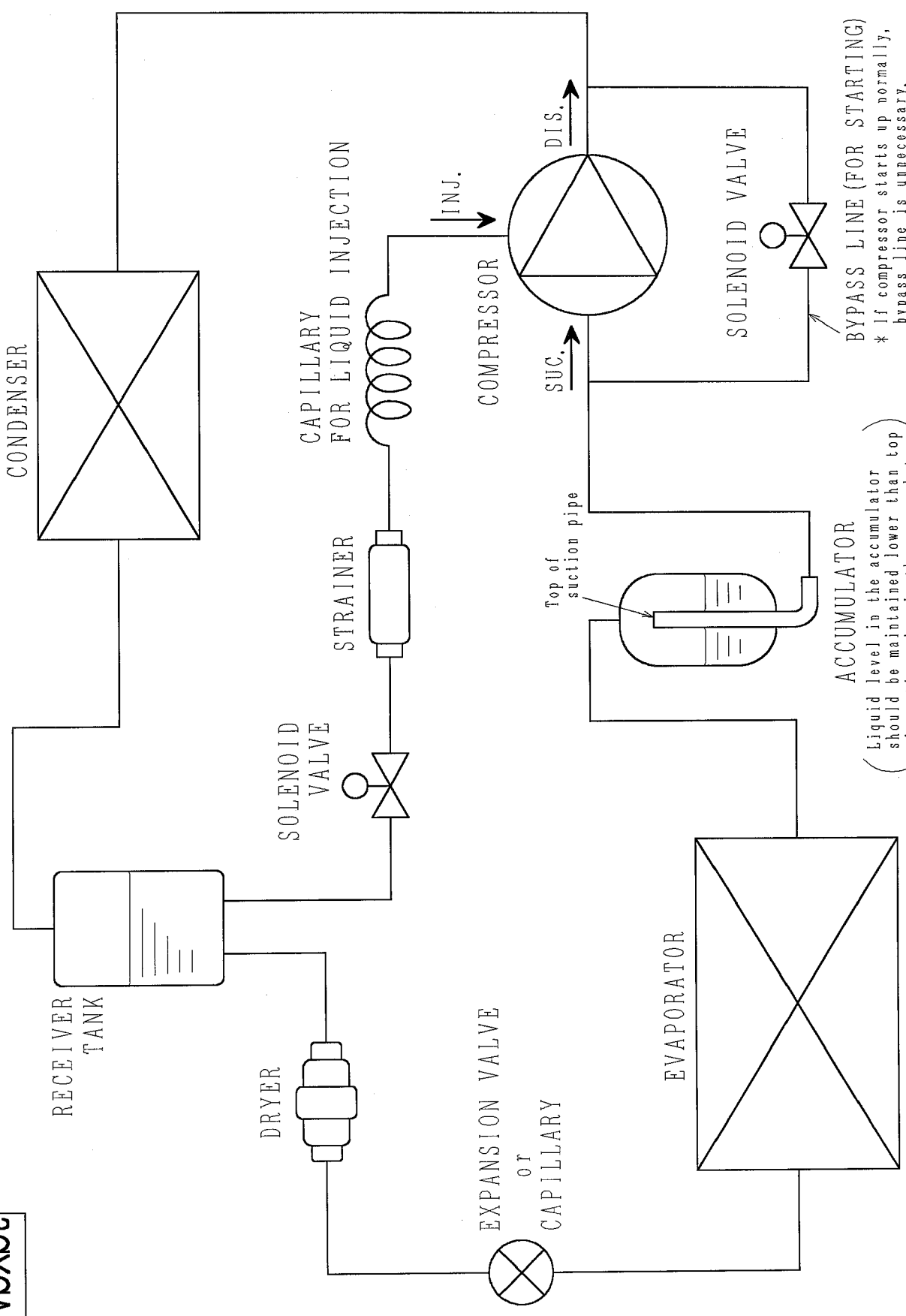

BYPASS LINE (FOR STARTING)
 * If compressor starts up normally,
 bypass line is unnecessary.

SIGNATURE	DATE	PROJECTION	SCALE	TITLE
SWR. M. Ogoouchi	2004-05-31		1:1	REFRIGERATION SYSTEM
CHKD. S. Tajawa	2004-05-31			
APPR. S. Tajawa	2004-05-31			

TOCHIGI DWG. No. Hitachi Home & Life Solutions, Inc. Tokyo Japan **3CYCA6131**



REGD 2004-06-02

001

BB0000793

CONDENSER

RECEIVER TANK

DRYER

SOLENOID VALVE

STRAINER

CAPILLARY FOR LIQUID INJECTION

EXPANSION VALVE
OR
CAPILLARY

COMPRESSOR

STRAINER

SUC. DIS.

EVAPORATOR

SOLENOID VALVE

ACCUMULATOR

BYPASS LINE (FOR STARTING)

(Liquid level in the accumulator must be maintained lower than top of suction pipe in the accumulator.)

* If compressor starts up normally, bypass line is unnecessary.

SIGNATURE		DATE	PROJECTION	SCALE	TITLE
DWN.	<i>K. Miyawaki</i>	2005.07.26	1:1	REFRIGERATION SYSTEM	REGD.
CHKD.	<i>M. Aoyama</i>	2005.07.26			
APPD.	<i>R. Shimada</i>	2005.07.26	Hitachi Home & Life Solutions, Inc. Tokyo, Japan		TOCHIGI DWG. No.
					3CYC BB0000793



100

6

7

8

318 } CYC62866

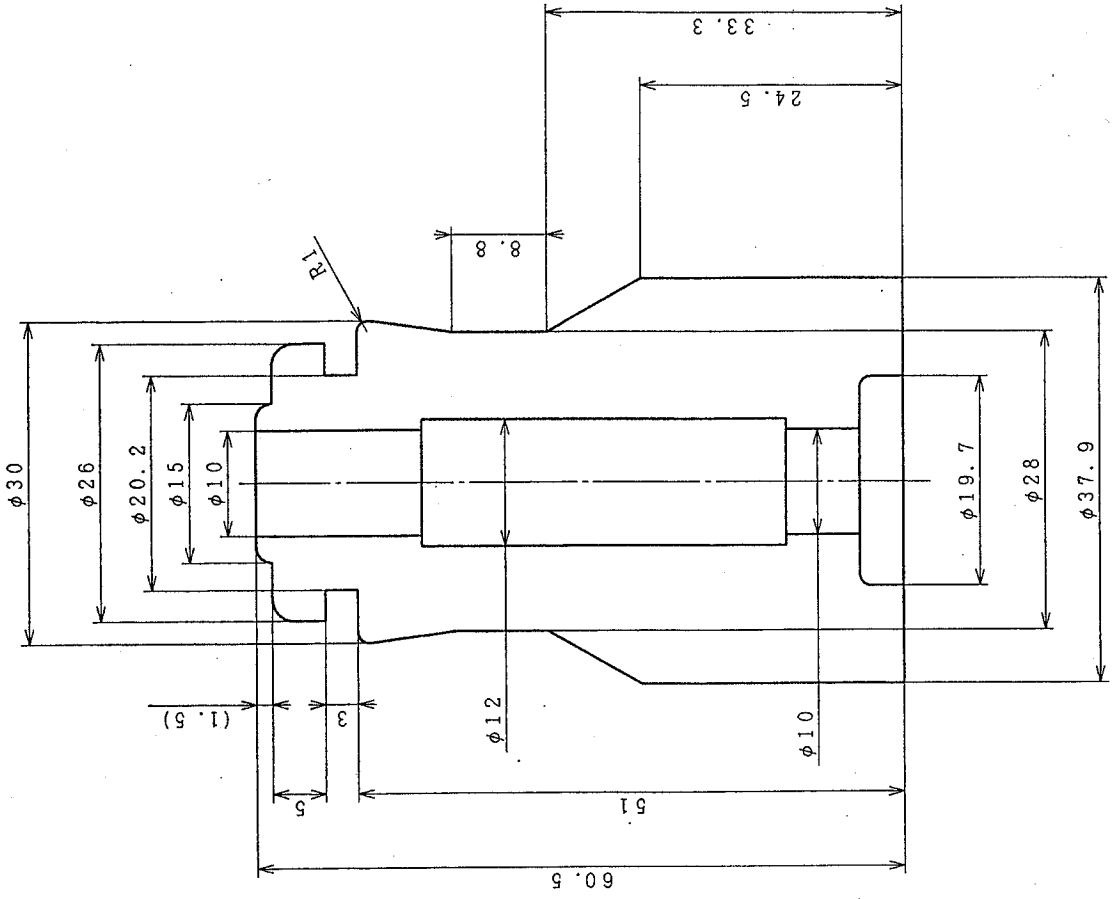

MATERIAL: NATURAL RUBBER

COLOR : BLACK

DIMENSION : mm

		PROJECTION SCALE	2:1
	Hitachi Ltd. Tokyo Japan		
51.9 	DWN. / <i>Y. Nakada</i> REGD. / <i>CHND. K. Nakada</i> 92-05-13	TITLE RUBBER GROMMET	TOCHIGI DWG. NO. 318 } CYC62866

1 2 3 4 5 6 7 8
 A B C D E F

4CYC11219

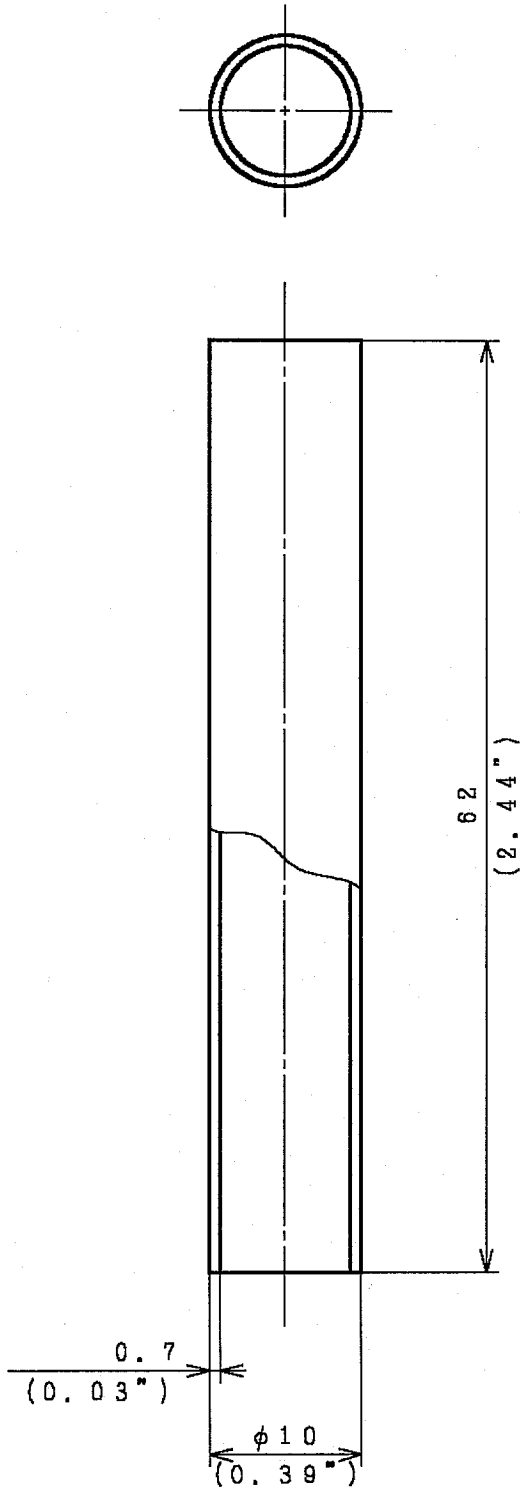

MATERIAL: STEEL PIPE
 DIMENSION: mm (in)

CAD

SIGNATURE		DATE	PROJECTION	SCALE	TITLE	
DWN.	<i>T. Nishio</i>	2003-10-27		2:1	PIPE	
CHKD.	<i>M. Onoguchi</i>	2003-10-28	Hitachi Home & Life Solutions, Inc. Tokyo Japan		TOCHIGI DWG. No. 4CYC11219	
APPD.	<i>A. Jimada</i>	2003-10-29				
					RE-REGD.	REGD. 2003-11 04

4CYC11220

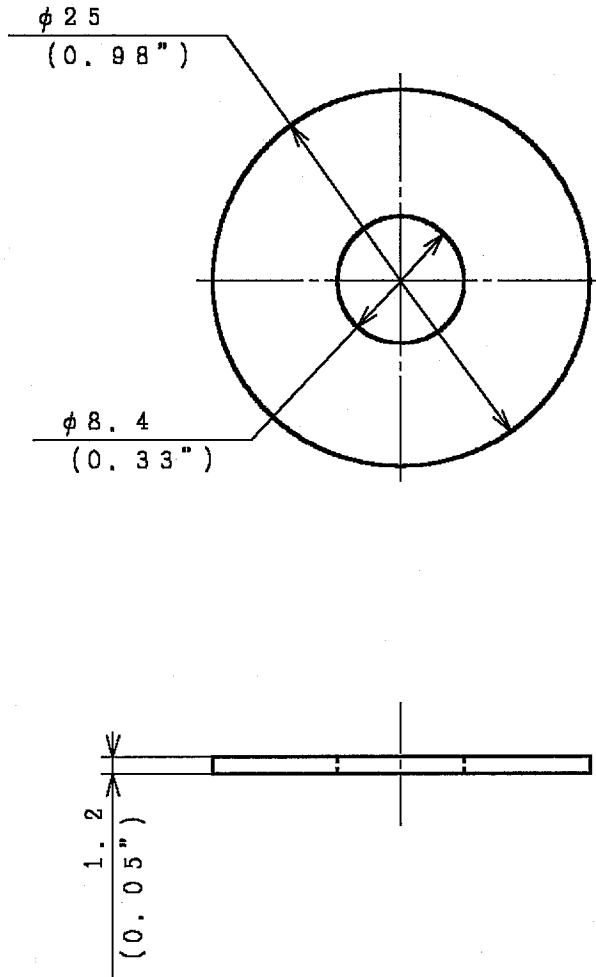

NOTES

MATERIAL: COLD ROLLED CARBON STEEL SHEETS
AND STRIP
SURFACE : ZINC-COATED
DIMENSION: mm (in)

CAD

SIGNATURE		DATE	PROJECTION	SCALE	TITLE
DWN.	<i>T. Nishio</i>	2003-10-27		2:1	WASHER
CHKD.	<i>M. Onoyachi</i>	2003-10-28			
APPD.	<i>A. Jimada</i>	2003-10-29			
			Hitachi Home & Life Solutions, Inc. Tokyo Japan		TOCHIGI DWG. No.
			4CYC11220		RE-REGD.

3CYCA4998

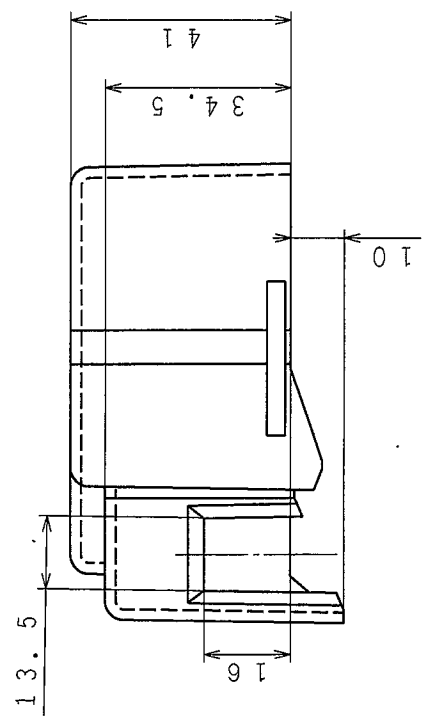
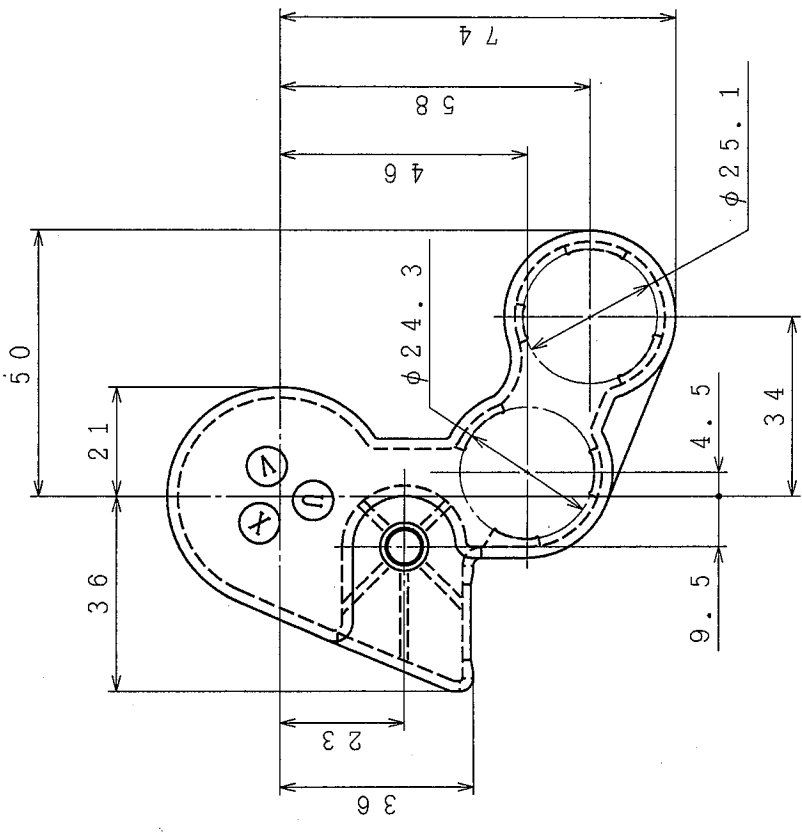
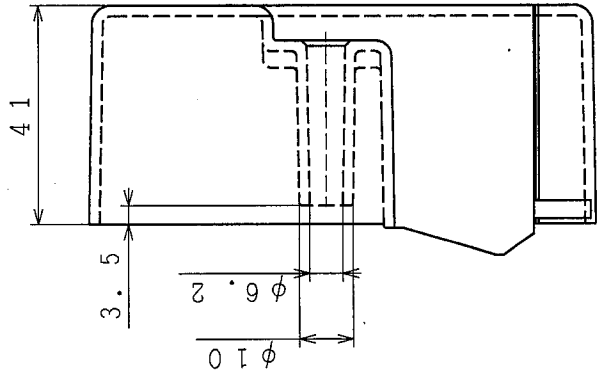

MATERIAL: PA66G-B-5V

SIGNATURE		DATE	PROJECTION	SCALE	TITLE
DWL. M. Aoyama		2003-10-28	Third Angle	NTS	HERM-COVER
CHKD. M. Odoouchi		2003-10-28			Hitachi Home & Life Solutions, Inc.
APPD. A. Shimada		2003-10-29			TOCHIGI DWG. No. 3CYCA4998
					Hitachi Home & Life Solutions, Inc. Tokyo Japan

DATE
REGD
2003-11
04

002

3CYCA4999

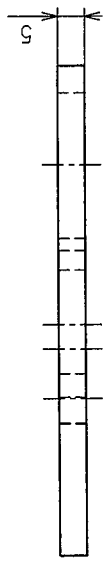
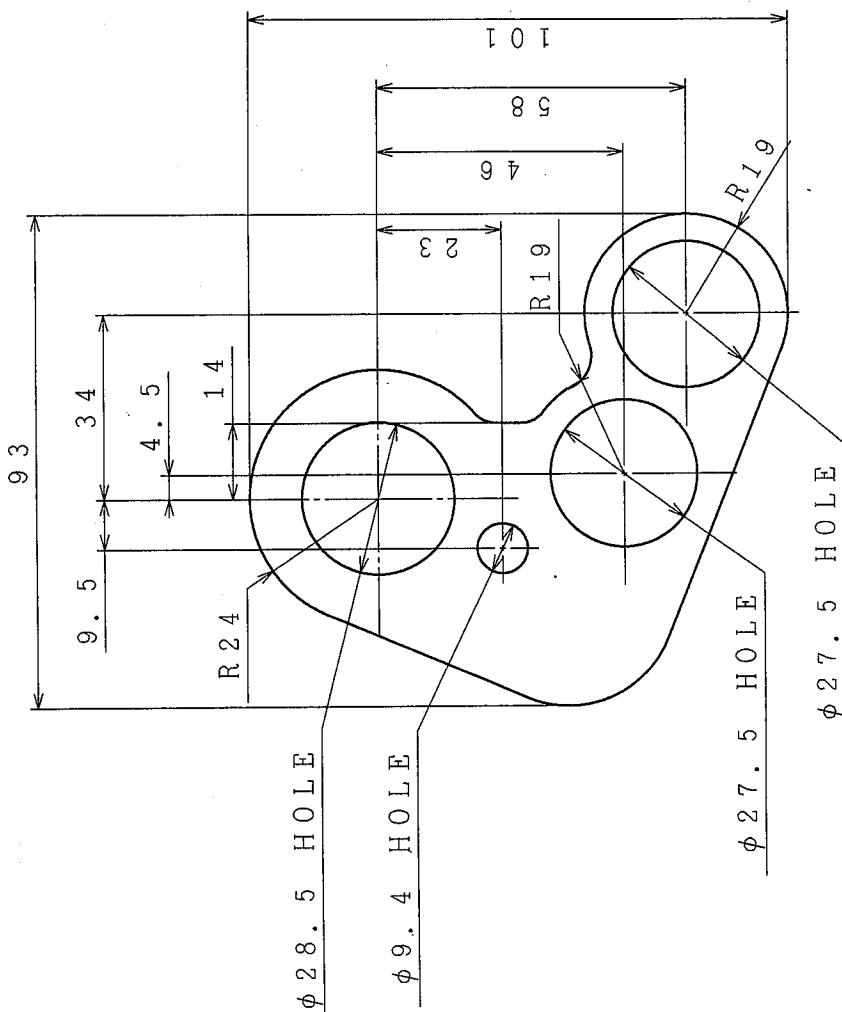

NOTES
 COLOR: BLACK
 MATERIAL: EPDMFOP-B

SIGNATURE	DATE	PROJECTION	SCALE	TITLE
DWR. M. Aoyama	2003-10-28		1:1	RUBBER PLATE
CHKD. M. Onouchi	2003-10-28			
APPD. A. Simada	2003-10-29	Hitachi Home & Life Solutions, Inc. Tokyo Japan 3CYCA4999 <small>TOCHIGI DWG. No.</small>		

REGD
 2003-11
 04



1:1

1

2

3

4

5

6

7

8

002

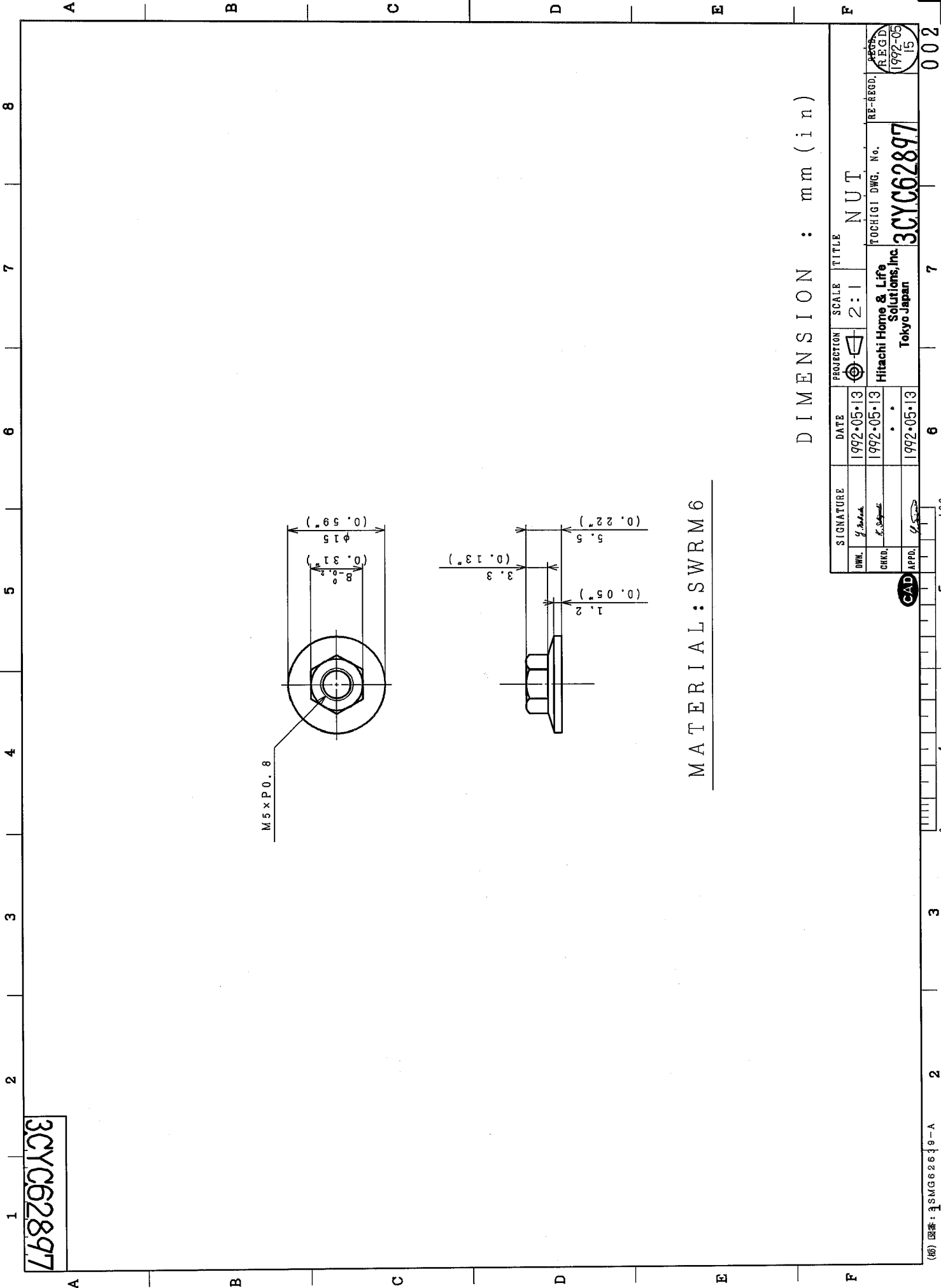

MATERIAL: SWRM6

DIMENSION : mm (in)

SIGNATURE	DATE	PROJECTION	SCALE	TITLE
<i>[Signature]</i>	1992-05-13		2:1	NUT
CHKD. <i>[Signature]</i>	1992-05-13	Hitachi Home & Life Solutions, Inc. Tokyo Japan		
APPD. <i>[Signature]</i>	1992-05-13	TOCHIGI DWG. No. 3CYC62897		
				REGD. 1992-05-15

3CYC62897

4CYC11207

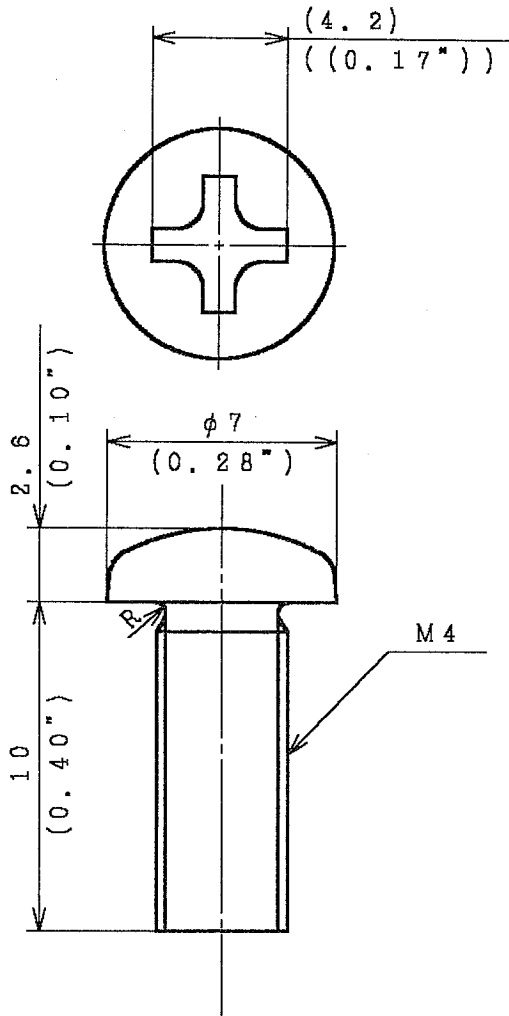

MATERIAL: CARBON STEEL WIRES FOR COLD HEADING
 AND COLD FORGING
 SURFACE FINISHING: ELECTROPLATED COATINGS OF
 ZINC ON IRON OR STEEL
 DIMENSION: mm (in)



SIGNATURE		DATE	PROJECTION	SCALE	TITLE
DWN.	<i>D. Muraishi</i>	2003-04-14		NTS	CROSS RECESSED HEAD SCREW
CHKD.	<i>M. Koyama</i>	2003-04-14	Hitachi Home & Life Solutions, Inc. Tokyo Japan		TOCHIGI DWG. No.
APPD.	<i>Y. Kobata</i>	2003-04-14			4CYC11207
					REGD. 2003-04-15

4CYC11206

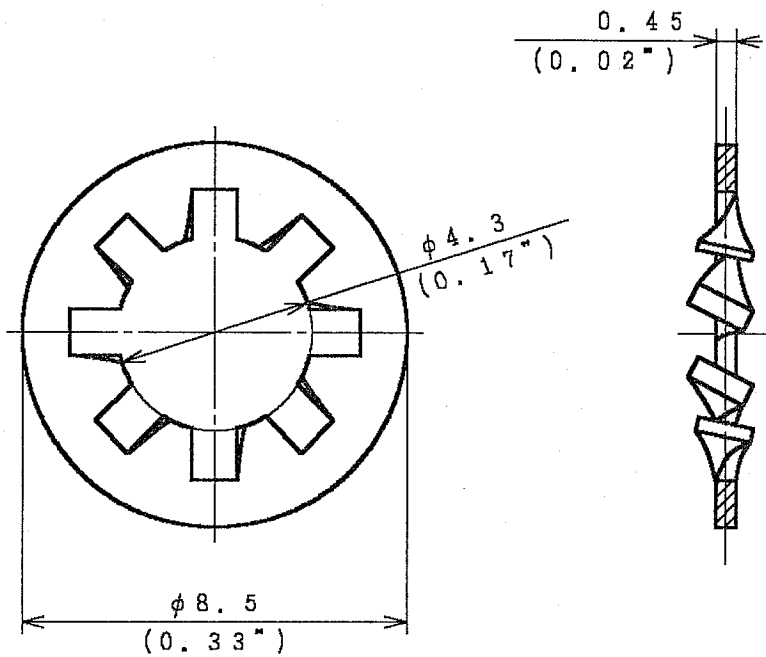

MATERIAL: COLD ROLLED SPECIAL STEEL STRIP
 SURFACE FINISHING: ELECTROPLATED COATINGS OF
 ZINC ON IRON OR STEEL
 DIMENSION: mm (in)

CAD

SIGNATURE		DATE	PROJECTION	SCALE	TITLE
DWN.	<i>M. Sato</i>	2003-04-08		NTS	TOOTHED LOCK WASHER
CHKD.	<i>M. Koyama</i>	2003-04-09	Hitachi Home & Life Solutions, Inc. Tokyo Japan		TOCHIGI DWG. No.
APPD.	<i>Y. Nakada</i>	2003-04-09	4CYC11206		RE-REGD. REGD. 2003-04-11

BB0004663

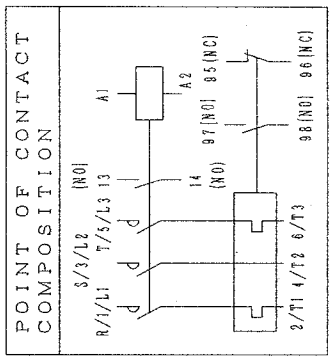
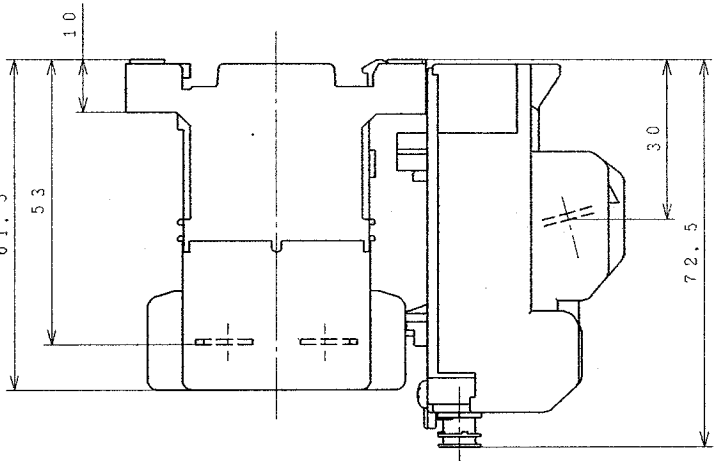
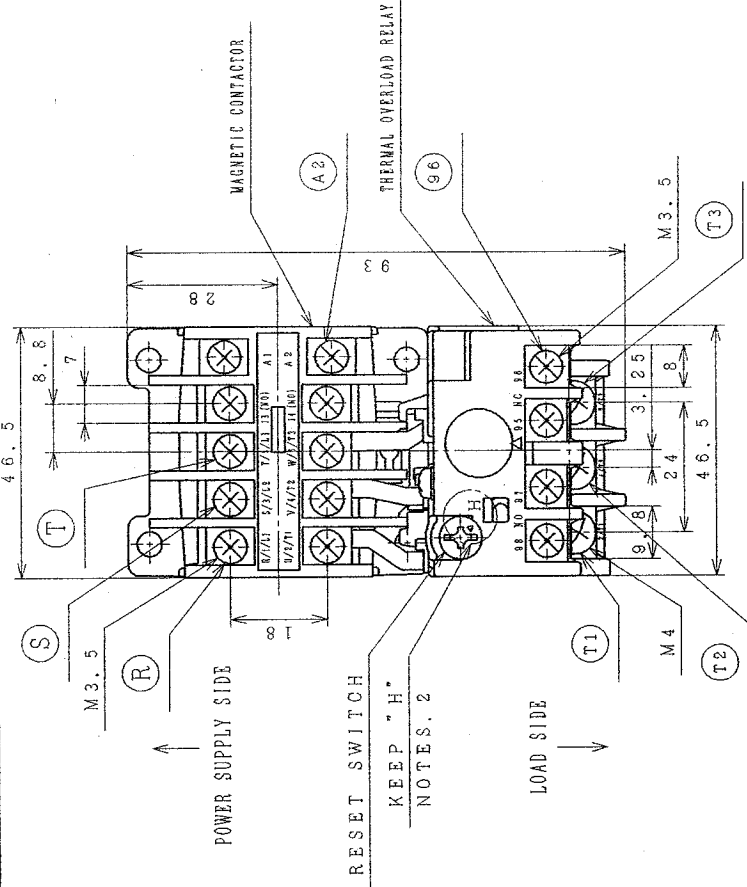

MODEL	RATED CURRENT
PAK-6JT-FC	5A

- NOTES
- The thermal overload relay are set for hand resetting.
 - Please use it in the state of hand resetting.
[Hand resetting mark "H"]
 - Please connect R, S and T to the power supply.
 - Please connect thermal over-load relay to a load side.
 - Please use it, connecting the operation coil A2 to the terminal number 96.
[Connect an operation coil [A1, A2] with a point of contact [95, 96] in series.]

SIGNATURE	DATE	PROJECTION	SCALE	TITLE
DMN. W. Sugawara	2006-07-19		1 : 1	THERMAL OVERLOAD RELAY
CHKD. M. Onoguchi	2006-07-19			TUCHIGI DWG. No.
APPD. A. Simizu	2006-07-19			Hitachi Appliances, Inc. Tokyo Japan

REC'D
REGD
2006-08
01

3CYCBB0004663

001

3CYCA2072

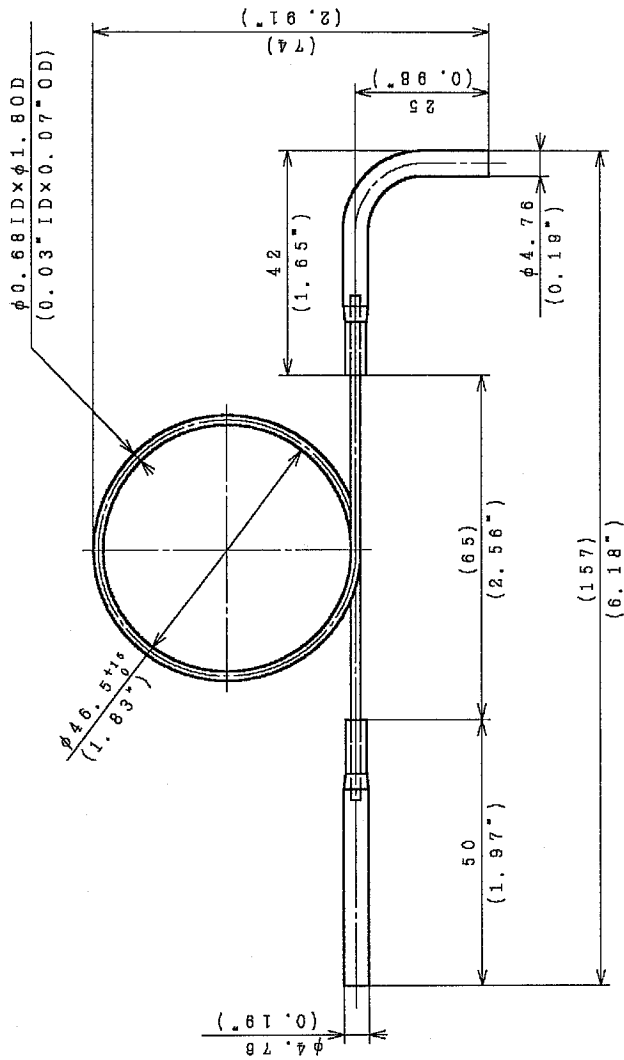

NOTES

1. RESISTANCE VALUE: 13.3KPa

(THE LENGTH OF THE PIPE IS APPROXIMATELY 280 (11.02") MILLIMETERS.)

DIMENSION: mm (in)

SIGNATURE	DATE	PROJECTION	SCALE	TITLE
<i>K. Honda</i>	2002-03-28		1:1	CAPILLARY FOR LIQUID INJECTION
<i>M. Nagata</i>	2002-03-28			TOCHIGI DWG. No.
<i>Y. Sasaki</i>	2002-03-28			REGD. 2002-03-29

Hitachi Home & Life Solutions, Inc.
Tokyo Japan

3CYCA2072



1 2 3 4 5 6 7 8

3CYCA5055

UPPER SIDE

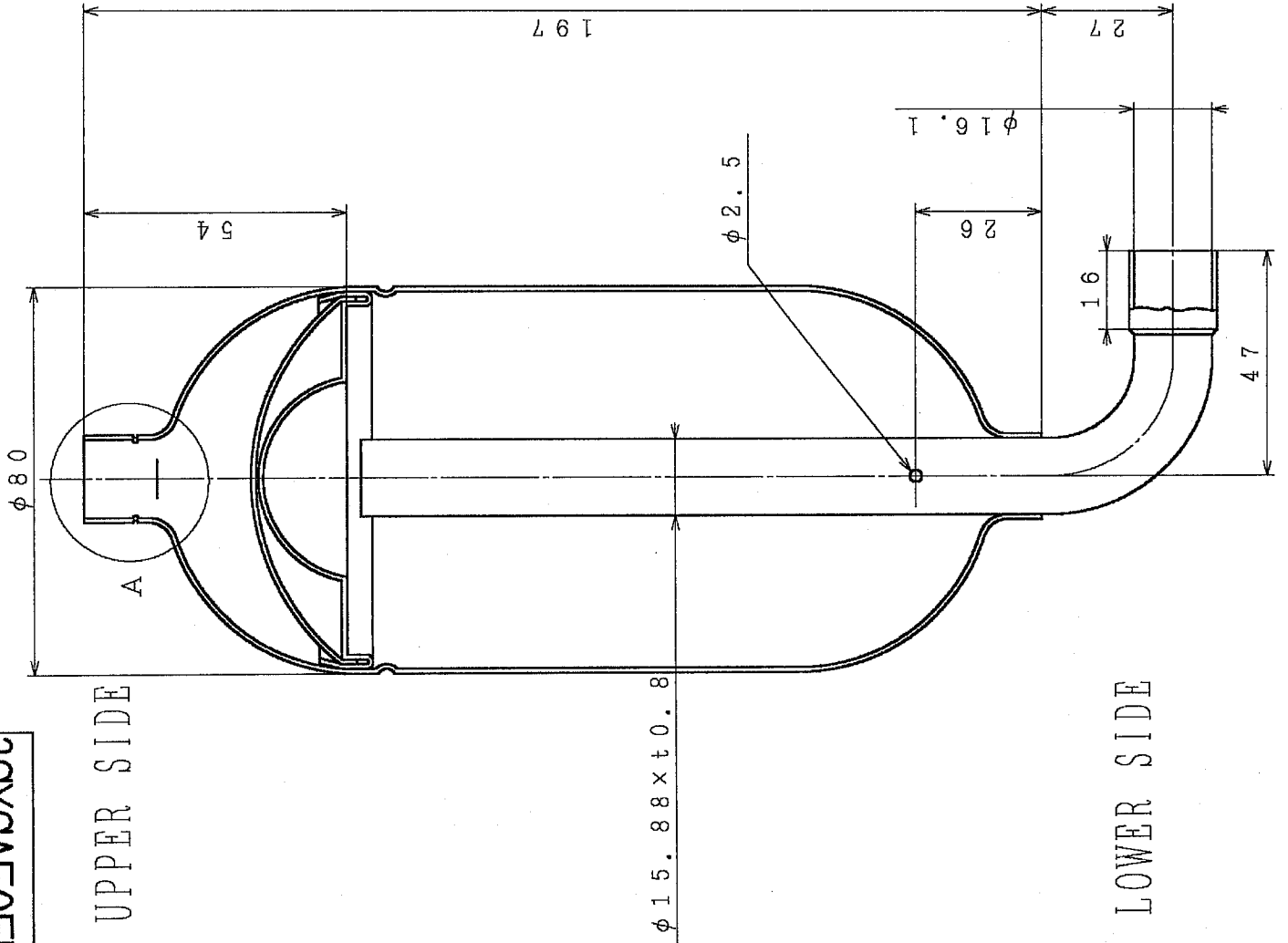

LOWER SIDE

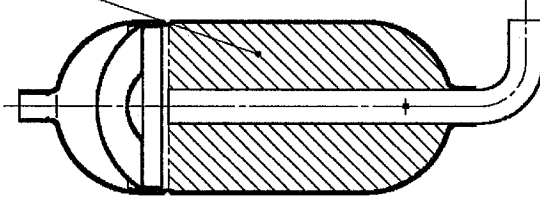

(NTS)

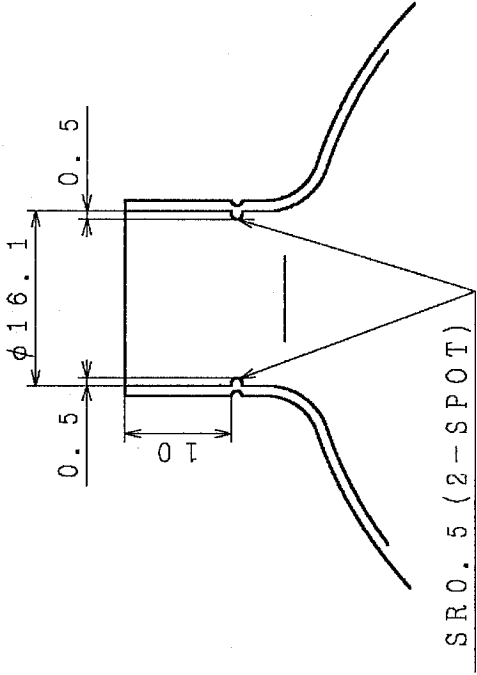

A (2:1)
VALID VOLUME: 530mL

注記

1. Use to stand upper A side vertically.
 2. The phosphor copper brazing be done while blowing or being full of N_2 gas.
 3. The total number: 2 pieces (Total valid volume: 1060ml)
- Use to connect accumulators in series.

SIGNATURE		DATE	PROJECTION	SCALE	TITLE
DWR.	<i>S. Kubota</i>	2003.11.05	①	1:1	ACCUMULATOR
CHD.	<i>M. Yamada</i>	2003.11.05			
APPD.	<i>A. Honda</i>	2003.11.05			
			Hitachi Home & Life Solutions, Inc. Tokyo Japan		
			TOCHIGI DWG. No. 3CYCA5055		
			JEP-REGD. 2003-11-06		
			REGD. 2003-11-06		

CAD

BB0000577

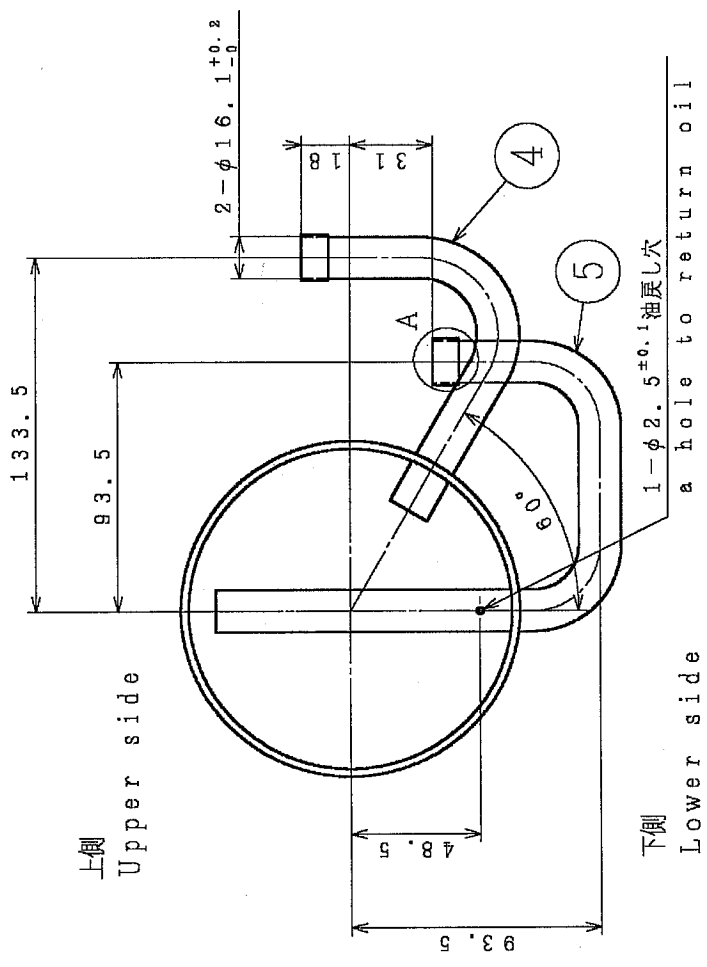

断面B-B (Cross section B-B)

品番	材質	JIS規格	備考
1	STKM11A	G3445	t2.9
2	SPHC	G3131	t4.0
3	SPHC	G3131	t4.0
4	C1220T-OL1	H3300	φ15.88×t0.8
5	C1220T-OL1	H3300	φ15.88×t0.8

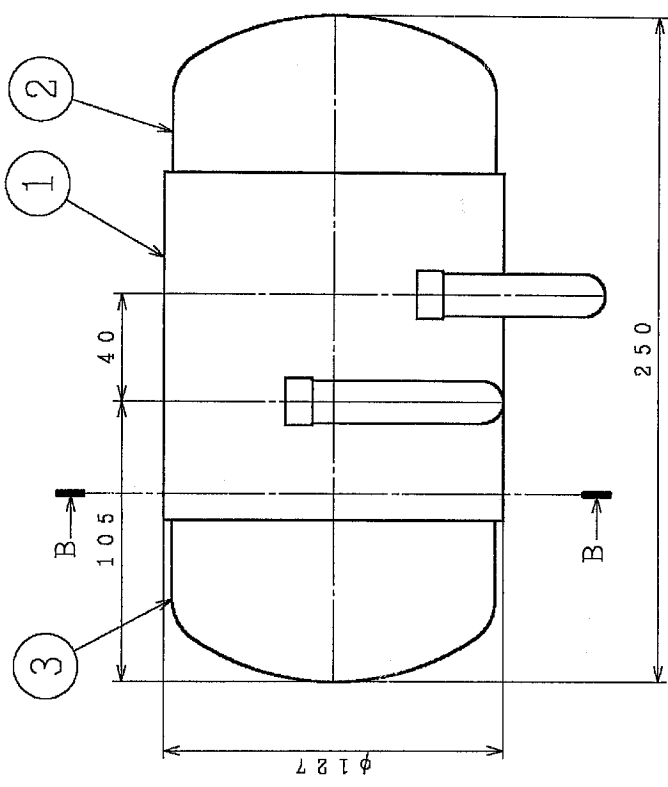

注記

1. A部を上側にして、垂直に立てて使用すること。
2. ロウ付けの際、内部が酸化せぬようN₂ガスを流してロウ付けのこと。
3. 総有効内容積：2300ml

Note

1. Use to stand upper A side vertically.
2. The phosphor copper brazing be done while blowing or being full of N₂ gas.
3. Total valid volume: 2300ml

SIGNATURE	DATE	PROJECTION	SCALE	TITLE
DWL. K. Matsunaga	2005-07-04	①	1:2	ACCUMULATOR
CHKD. M. Otaguchi	2005-07-04			
APPD. A. Simada	2005-07-04			
Hitachi Home & Life Solutions, Inc. Tokyo-Japan				TOCHIGI DWG. No. 3CYCBB0000577
				REGD. 2005-07 001

BB0004668

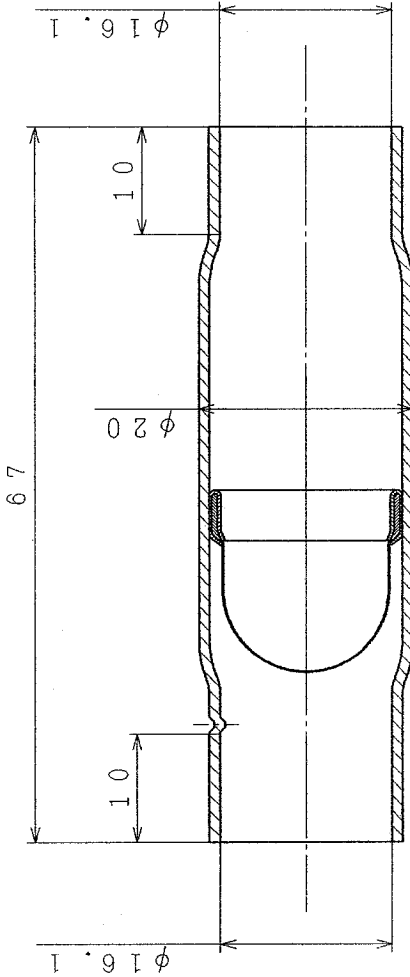

Direction of refrigerant flow

Notes

1. The strainer must be connected so that a refrigerant flows through a direction.
2. The phosphor copper brazing be done while blowing or being full of N_2 gas.

SIGNATURE	DATE	PROJECTION	SCALE	TITLE
DWN. <i>M. Sugawara</i>	2006.08.04		2 : 1	STRAINER
CHKD. <i>M. Haseguchi</i>	2006.08.04			TOCHIGI DWG. No.
APPD. <i>A. Yamada</i>	2006.08.09			Hitachi Appliances, Inc. Tokyo Japan
				REGD. No. 3CYC BB0004668

