

# MARSTAIR

REFRIGERATION AND SPECIALIST AIR CONDITIONING

## TECHNICAL MANUAL & INSTALLATION INSTRUCTION

SEE ALSO 56408020 INTERCONNECTING INSTRUCTIONS



### GENERAL

1. TEV Ltd recommend that personnel working on this equipment be skilled and fully conversant with the appropriate Air Conditioning, Refrigeration and Electrical practices and have sound knowledge of current Industrial Safe Working practices.
2. These units contain live electrical components, moving parts and refrigerant under pressure. Always site out of reach of children and protect from vandalism.
3. The data plate only gives information for the particular unit. For system details add input power and current of indoor and outdoor unit, including any heater load.
4. NOTE: The New 17 series CKA's are pre-charged for 7.5 metre pipe run. The older models of the CKA's have a small nitrogen charge. Please check before installation.

**CX(E)A & CKA SYSTEMS**

# DIMENSIONS & WEIGHTS

All dimensions in mm

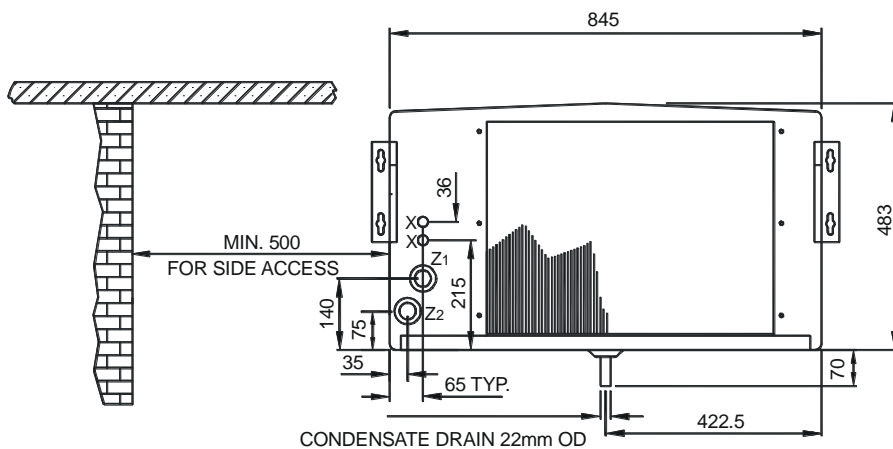
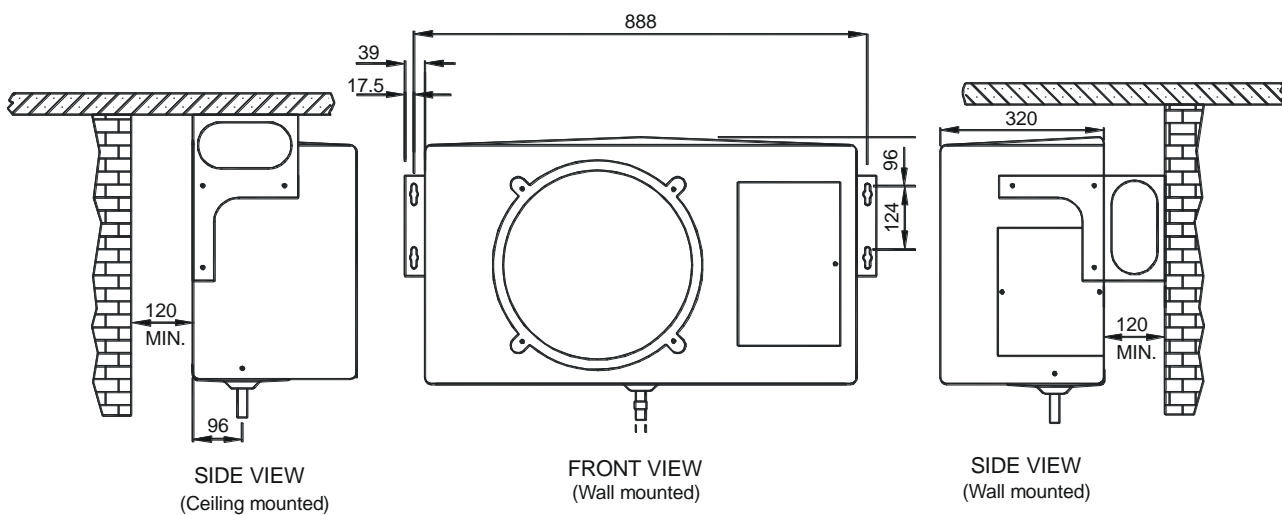
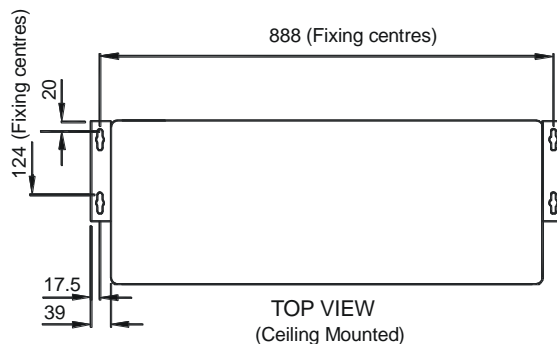

X = Interconnecting Wiring  
Z<sub>1</sub> = Suction  
Z<sub>2</sub> = Liquid / Expansion

DIMENSIONS (mm)

| Model     | Weight (kg) |
|-----------|-------------|
| CX(E)A 30 | 18          |
| CX(E)A 50 | 20          |
| CX(E)A 70 | 23          |

# CKA ARRANGEMENT

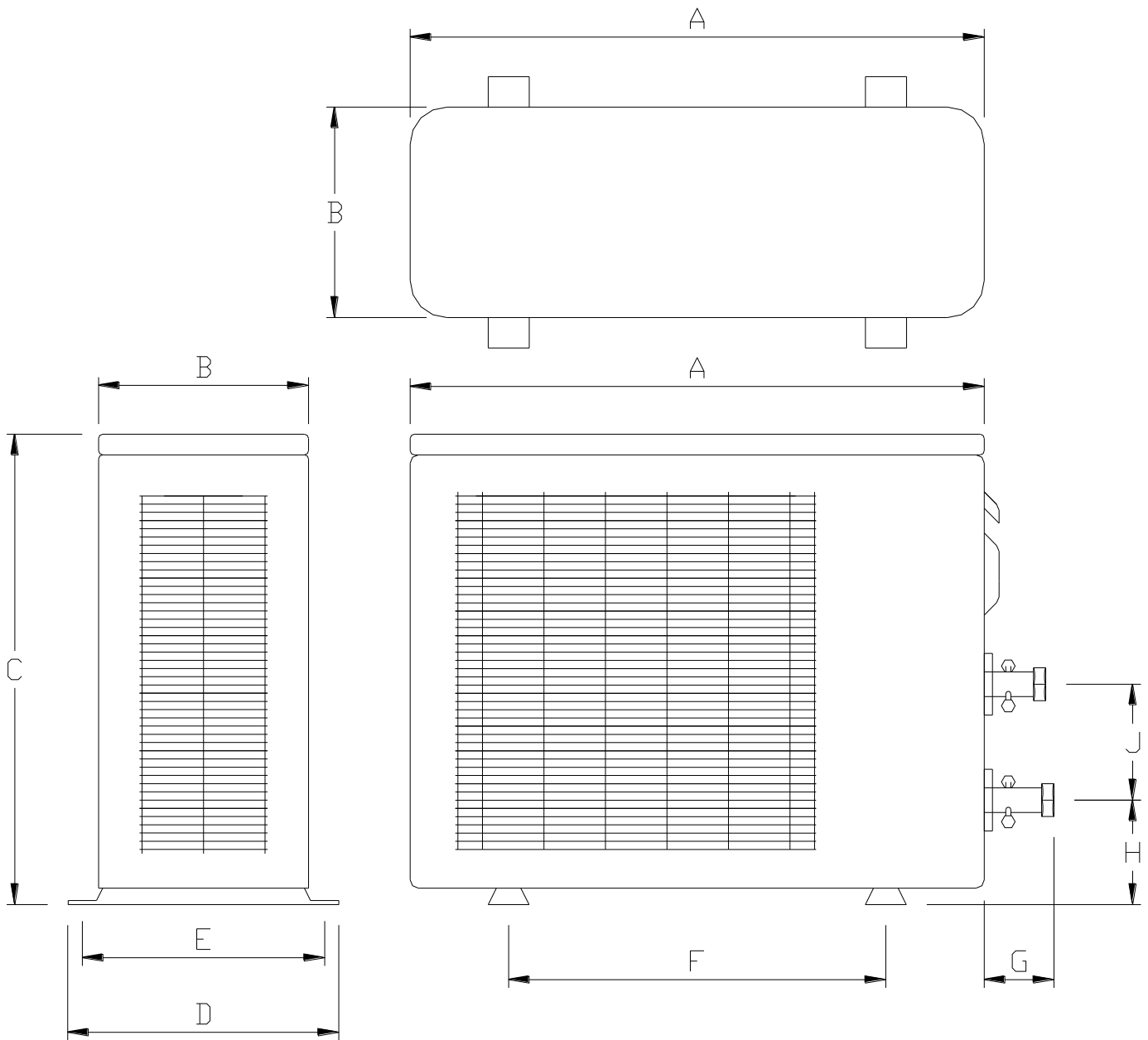

|                            | CKA 35 | CKA 50 | CKA 70 |
|----------------------------|--------|--------|--------|
| A (mm)                     | 760    | 760    | 860    |
| B (mm)                     | 256    | 256    | 307    |
| C (mm)                     | 552    | 552    | 660    |
| D (mm)                     | 330    | 330    | 370    |
| E (mm)                     | 290    | 290    | 340    |
| F (mm)                     | 510    | 510    | 630    |
| G (mm)                     | 50     | 50     | 50     |
| H (mm)                     | 85     | 85     | 85     |
| J (mm)                     | 70     | 70     | 70     |
| WEIGHT                     | 35Kg   | 42Kg   | 56Kg   |
| Valve Size LIQUID (upper)  | 1/4"   | 1/4"   | 3/8"   |
| Valve Size SUCTION (lower) | 1/2"   | 1/2"   | 5/8"   |

# INSTALLATION

| CONTENTS   |     |                       |
|--|-----|-----------------------|
| PARTS DESCRIPTION  | QTY | ACTION                |
| Envelope containing operating instructions and Declaration of Conformity | 1   | Pass to the end user. |

|                       |  |   |                                    |
|-----------------------|--|---|------------------------------------|
| Drain Stub/Nut/Gasket |  | 1 | Fitted by installer.               |
| Drain stub adaptor    |  | 1 | Convert to 3/4" drain if required. |
| Screw M5              |  | 6 | To fix brackets to unit.           |
| Washer nylon          |  | 6 | To fix brackets to unit.           |

The unit may be mounted on a wall or solid ceiling using brackets supplied. It should be matched with the appropriately sized outdoor unit; this instruction should be used in conjunction with the outdoor unit installation instructions.

## UNIT COMBINATIONS

| Minimum Set Temperature 8°C |              |
|-----------------------------|--------------|
| INDOOR UNIT                 | OUTDOOR UNIT |
| CX(E)A 30                   | CKA35        |
| CX(E)A 50                   | CKA35        |
| CX(E)A 50                   | CKA50        |
| CX(E)A 70                   | CKA70        |

1. Fit all kits prior to installing the unit. (Heater kit is easier to fit when unit has been mounted).
2. Ensure that the mounting surface will support the operating weight of the unit (see table below).
3. Mark out the mounting positions and drill holes to suit 6mm rawlbolt shields or equivalent strength fasteners (ensure that the unit is positioned to give sufficient access (min 0.5m) to the removable side panel).
4. Fix the mounting brackets to the unit in the correct position for wall or ceiling mounting.
5. Raise the unit into position and secure the fixings, ensuring that it is square and level.
6. Remove the drain tray then fit the drain stub, nut & gasket. Refit the drain tray.

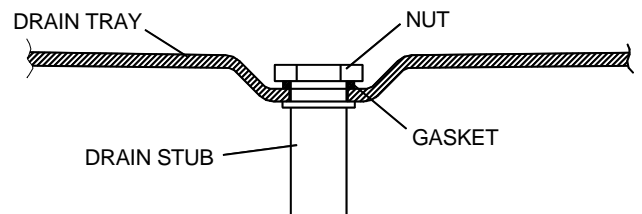

## NITROGEN CHARGE

The indoor units CX(E)A contain a small charge of dry nitrogen, which should be discharged into the atmosphere. This is a non-toxic, non-ozone depleting gas with no global warming potential.

**The new 17 Series CKA are pre-charged with R410A Refrigerant.**

## CKA

| CKA Part numbers |       |
|------------------|-------|
| 56517002         | CKA35 |
| 56517003         | CKA50 |
| 56517004         | CKA70 |

The older series of CKA's have a nitrogen charge

| CKA Part numbers |       |
|------------------|-------|
| 56500002         | CKA35 |
| 56500003         | CKA50 |
| 56500004         | CKA70 |

**NOTE: Please check this before installation.**

# CKA INSTALLATION

## MOUNTING

Whether floor or wall mounted, it is essential that the mounting surface is capable of supporting the unit weight. Leave space around the unit for air circulation and access for installation and maintenance.

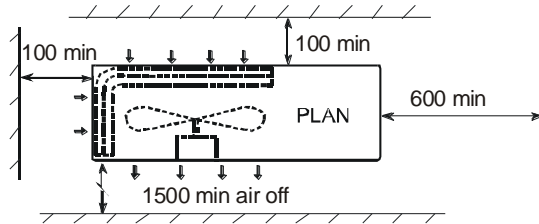

## CKA PIPEWORK

**NOTE: Please check this before installation.**

### MAXIMUM EQUIVALENT PIPE LENGTHS 25m

1. Performance is based on 15m pipe runs. Allow a 3.5% reduction in capacity for pipe runs above 15m.
2. In calculating equivalent lengths of pipe runs, the effect of bends and fittings must be taken into account. The table below covers the fittings most likely to be encountered in this installation.

The equivalent lengths of all the fittings in a pipe run should be added together and the total added to the actual pipe length in order to calculate the total equivalent length.

3. Use the shortest possible route, avoiding sharp bends.
4. Completely insulate the suction line, fully over the indoor unit drain tray.

### FITTING LOSSES, in equivalent straight lengths of pipe (m).

| FITTING             | Pipe Size OD |      |      | To calculate the total equivalent length, the equivalent lengths of all fittings in a pipe run must be added to the actual length of pipe in the run: these are the fittings most likely to be used.<br><br>R = Radius of bend<br>d = Diameter of tube<br>C = Centres of bend |
|---------------------|--------------|------|------|---|
|                     | 3/8"         | 1/2" | 5/8" |   |
| 45° Bend            | 0.12         | 0.15 | 0.18 |   |
| 90° Bend R/d = 1    | 0.37         | 0.43 | 0.49 |   |
| 90° Bend R/d = 1.5  | 0.24         | 0.27 | 0.30 |   |
| 180° Bend R/d = 1.5 | 0.73         | 0.91 | 1.10 |   |
| 180° Bend C/d = 2.5 | 0.46         | 0.55 | 0.64 |   |
| 90° Elbow           | 0.67         | 0.85 | 1.04 |   |

### A. SUCTION AND LIQUID/EXPANSION LINES:

The expansion capillary is located in the outdoor unit and the equivalent pipe run is 25m maximum, including a maximum lift of 7.5m. Fully insulate the suction and liquid/expansion line. Ensure the suction pipe is insulated well over the drain tray at the indoor unit. Liquid lines should be routed to avoid hot areas. This prevents flash gas forming, which may result in erratic control of liquid refrigerant to the evaporator.

| SYSTEM            | MAXIMUM EQUIVALENT LENGTH OF SUCTION LINE PIPE SIZES (m) |      | LIQUID/EXPANSION LINE |      | TOTAL CHARGE (kgs) for 7.5m supplied in 17 series units only |
|-------------------|--|------|-----------------------|------|--|
|                   | 1/2"   | 5/8" | 1/4"                  | 3/8" |  |
| CX(E)A30 + CKA 35 | 25   | -    | 25                    | -    | 0.724  |
| CX(E)A50 + CKA 35 | 25   | -    | 25                    | -    | 0.856  |
| CX(E)A50 + CKA 50 | 25   | -    | 25                    | -    | 1.306  |
| CX(E)A70 + CKA 70 | -  | 25   | -                     | 25   | 1.882  |

**For systems with interconnecting pipework in excess of 7.5 metre add 20gms per metre on CKA 35 & CKA 50, add 30gms per metre on CKA 70. No additional oil is required.**

## PIPE CONNECTIONS

Units are supplied with the following male flare connections (sizes in inches):

| INTERCONNECTING PIPEWORK (Max 25 metres) |                      |         |                |                 |                |                 |
|--|----------------------|---------|----------------|-----------------|----------------|-----------------|
| System                                   | Liquid/<br>Expansion | Suction | Torque (NM)    |                 | Nut A/F (mm)   |                 |
|  |                      |         | Liquid<br>Line | Suction<br>Line | Liquid<br>Line | Suction<br>Line |
| CX(E)A 30 + CKA35                        | 1/4"                 | 1/2"    | 17             | 54              | 17             | 24              |
| CX(E)A 50 + CKA35                        | 1/4"                 | 1/2"    | 17             | 54              | 17             | 24              |
| CX(E)A 50 + CKA50                        | 1/4"                 | 1/2"    | 17             | 54              | 17             | 24              |
| CX(E)A 70 + CKA70                        | 3/8"                 | 5/8"    | 34             | 73              | 22             | 27              |

## INTERCONNECTING PIPEWORK

- The Indoor unit has a low pressure charge of N<sub>2</sub>, which may be safely released into the atmosphere before connection. The service valves on the outdoor unit should remain closed (IN, fully clockwise) until pipework has been fitted, and system evacuated.
- Connecting the pipework
  - Remove the flare nuts from the suction and liquid service valves.
  - Ensure that the suction line is fully insulated: if an expansion line is used this should also be fully insulated.
  - Place the flare nuts over the incoming pipework and flare the pipe ends. The use of a little refrigeration oil on the flaring tool will help.
  - Connect the pipework between the units. Do not leave pipe ends, valves etc. open to the atmosphere.  
R410A is very hygroscopic, and will absorb damaging levels of moisture if left open. Always use two spanners when tightening the flare nuts to avoid twisting the pipes. Use a small amount of refrigerant oil on the mating surfaces.
  - Sight glasses and filter driers are not necessary, but if required should be fitted between the outdoor unit liquid shut off valve and the expansion device.

## CKA REFRIGERANT

### EVACUATING (DO NOT RELEASE THE OUTDOOR UNIT SERVICE VALVES) UNTIL THE SYTEM IS EVACUATED.

- Release the nitrogen holding charge in the indoor unit to atmosphere. Connect a vacuum pump to the service ports on the outdoor unit valves and evacuate the system to 1000 microns (1 Torr) or better and allow to be held for a minimum of 15 minutes.
- Replace the caps on the service ports, (torque to 25NM).

### ADDING REFRIGERANT

- A 3-minute delay occurs between successive compressor operations.
- R410A should be introduced through the Schrader valve on the indoor unit, or the service port on the suction service valve on the outdoor unit. **No other refrigerant must be used.**

**NOTE: LABEL R410A POE (supplied loose) TO BE FIXED ABOVE SERVICE VALVES.**

- Run the system for a few minutes to allow it to stabilize. Where possible, charge to a sweat line on the evaporator. Typical suction pressure on short lines at UK conditions should be approx. **6.2bar (90 psig)**

## CONDENSATE DRAIN

Push fit connections are widely available for the 7/8" (22mm) OD condensate drain and 3/4"(19mm) ID drain stub adaptor. Alternatively 7/8" (22mm) bore plastic tubing may be fitted directly to the stub/adaptor with a hose clamp. Take care not to over tighten hose clamps as this could damage the stub pipe.

## ELECTRICAL CONNECTIONS

- Cables are routed to the terminal block via the cable cord grips at the rear of the unit and then through the back of the electrics box (see page 2).
- Cables **MUST** be size compatible with the recommended system fuse.

## FUSES

| SYSTEM           | COOL ONLY |     | WITH ELECTRIC HEATER |     |
|------------------|-----------|-----|----------------------|-----|
|                  | 1PH       | 3PH | 1PH                  | 3PH |
| CX(E)A30 + CKA35 | 16A       | -   | 16A                  | -   |
| CX(E)A50 + CKA35 | 20A       | -   | 20A                  | -   |
| CX(E)A50 + CKA50 | 20A       | -   | 20A                  | -   |
| CX(E)A70 + CKA70 | 20A       | -   | 32A                  | -   |

## ELECTRICAL DATA

|                         |       |       |       |       |
|-------------------------|-------|-------|-------|-------|
| Indoor CX(E)A           | 30    | 50    | 50    | 70    |
| Outdoor CKA             | 35    | 35    | 50    | 70    |
| Rated Current Cooling   | 5.2A  | 5.2A  | 8.0A  | 11.0A |
| Maximum Running Current | 7.3A  | 7.3A  | 10.8A | 14.2A |
| Starting Current        | 26.0A | 26.0A | 40.0A | 61.0A |

## ELECTRICAL DATA.

### UNIT ELECTRICAL LOADS [230V 50Hz 1Ph (A) or 400V 50Hz 3Ph (A/Ph)]

| MODEL     | FAN MOTOR | HEATER |
|-----------|-----------|--------|
| CX(E)A 30 | 0.8       | 13.0   |
| CX(E)A 50 | 0.8       | 13.0   |
| CX(E)A 70 | 0.8       | 13.0   |

## INTERCONNECTING INSTRUCTIONS FOR CX(E)A AND CKA SYSTEMS

### INTERCONNECTING WIRING

2 CORE + EARTH 1.5mm

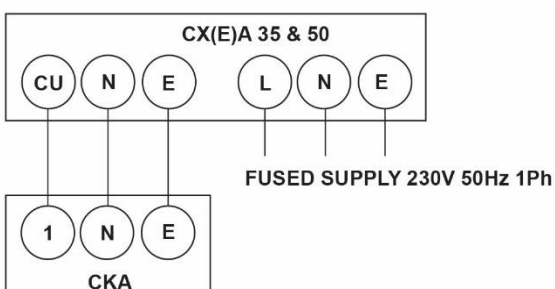

3 CORE + EARTH 1.5mm

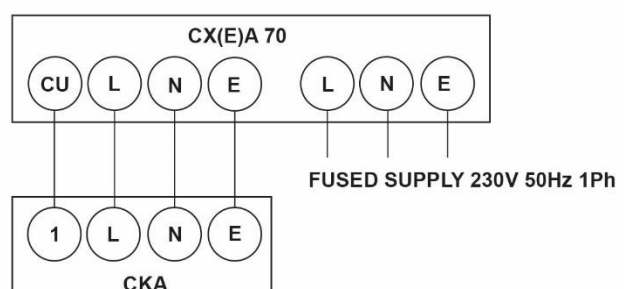

## CX(E)A OPTIONS

| OPTIONAL KITS |  |
|---------------|--|
| PART NUMBER   | DESCRIPTION  |
| 55900700      | 3kW heater (CXA only)                                |
| 55900701      | Digital temperature display (CXA only) STD on CX(E)A |
| 55900702      | De-ice thermostat (CXA only) STD on CX(E)A           |
| 55900715      | 3kW heater (CX(E)A only)                             |

## DIMENSIONS & WEIGHTS

| MODEL  | UNPACKED (all in mm) |       |       |        |
|--------|----------------------|-------|-------|--------|
| CX(E)A | HEIGHT               | WIDTH | DEPTH | WEIGHT |
| 30     | 483                  | 845   | 320   | 18     |
| 50     | 483                  | 845   | 320   | 20     |
| 70     | 483                  | 845   | 320   | 23     |

| PACKED (all in mm) |       |       |        |
|--------------------|-------|-------|--------|
| HEIGHT             | WIDTH | DEPTH | WEIGHT |
| 530                | 950   | 370   | 21     |
| 530                | 950   | 370   | 23     |
| 530                | 950   | 370   | 26     |

| CKA | HEIGHT | WIDTH | DEPTH | WEIGHT |
|-----|--------|-------|-------|--------|
|     |        |       |       | 1Ph    |
| 35  | 552    | 760   | 256   | 35     |
| 50  | 552    | 760   | 256   | 42     |
| 70  | 660    | 860   | 307   | 56     |

| HEIGHT | WIDTH | DEPTH | WEIGHT |
|--------|-------|-------|--------|
|        |       |       | 1Ph    |
| 620    | 863   | 376   | 38     |
| 620    | 863   | 376   | 46     |
| 730    | 990   | 415   | 63     |

## PERFORMANCE DATA (kW)

| MODEL              | RATING CONDITIONS<br>(ROOM 12.7°C / 10°C) (AMBIENT 27°C / 19°C) |          | OPTIONAL ELECTRIC HEATER |      |
|--------------------|---|----------|--------------------------|------|
|                    | TOTAL   | SENSIBLE | 240V                     | 230V |
|                    | CX(E)A 30 + CKA 35  | 2.28     | 1.98                     | 3.25 |
| CX(E)A 50 + CKA 35 | 3.25  | 2.48     | 3.25                     | 3.0  |
| CX(E)A 50 + CKA 50 | 4.25  | 2.90     | 3.25                     | 3.0  |
| CX(E)A 70 + CKA 70 | 5.60  | 3.83     | 3.25                     | 3.0  |

| MODEL              | RATING CONDITIONS<br>(ROOM 12.7°C / 10°C) (AMBIENT 35°C / 19°C) |          | OPTIONAL ELECTRIC HEATER |      |
|--------------------|---|----------|--------------------------|------|
|                    | TOTAL   | SENSIBLE | 240V                     | 230V |
|                    | CX(E)A 30 + CKA 35  | 2.20     | 1.77                     | 3.25 |
| CX(E)A 50 + CKA 35 | 2.83  | 2.15     | 3.25                     | 3.0  |
| CX(E)A 50 + CKA 50 | 3.50  | 2.45     | 3.25                     | 3.0  |
| CX(E)A 70 + CKA 70 | 4.62  | 3.24     | 3.25                     | 3.0  |

Allow a 3.5% reduction in capacity for pipe runs above 15m.

## AIRFLOWS

| MODEL     | m³/s |
|-----------|------|
| CX(E)A 30 | 0.61 |
| CX(E)A 50 | 0.66 |
| CX(E)A 70 | 0.58 |

| MODEL  | m³/s |
|--------|------|
| CKA 35 | 0.81 |
| CKA 50 | 0.78 |
| CKA 70 | 0.70 |



# SOUND POWER AND SOUND PRESSURE LEVELS

## INDOOR UNIT

| MAXIMUM SPEED    | SOUND PRESSURE LEVELS |
|------------------|-----------------------|
|                  | dB(A)                 |
| <b>CX(E)A 30</b> | 39.0                  |
| <b>CX(E)A 50</b> | 40.5                  |
| <b>CX(E)A 70</b> | 39.9                  |

*Sound Pressure Levels in dB(A) at 10m distance in free field conditions. (Reference  $2 \times 10^{-5} \text{ N/m}^2$ )*

## OUTDOOR UNIT

| MAXIMUM SPEED | SOUND PRESSURE LEVELS |
|---------------|-----------------------|
|               | dB(A)                 |
| <b>CKA 35</b> | 41.5                  |
| <b>CKA 50</b> | 44.5                  |
| <b>CKA 70</b> | 44.5                  |

*Sound Pressure Levels in dB(A) at 10m distance in free field conditions. (Reference  $2 \times 10^{-5} \text{ N/m}^2$ )*

# CXE(A) ELECTRONIC COOLING SYSTEM CONTROLS

### TEMPERATURE CONTROL (Do not set the controller below 8°C.)

The SET temperature is factory set at 12°C.

The digital display normally displays the return air temperature.

**To change the SET temperature**, press and hold down the SET button. If no alarms active, the 'St1' label appears and the current value is shown on the screen and will flash.

**To change the Setpoint value**, press ▲ and ▼ keys within 60 seconds. The display will revert to the return air temperature after 60 seconds.

The fitted de-ice thermostat will activate a de-ice cycle when there is a build-up of ice on the evaporator coil.

Cellarators will only heat a room if the electric heater option is fitted.

### WARNING

The following actions could damage your system:

- 1. Switching the unit OFF and ON quickly**
- 2. Setting the unit to HEAT and then back to COOL quickly**

**NB:** Allow at least 3 minutes between the above actions.

