

SLIM DUCT LOW PRESSURE



THE PANEL KIT (OPTIONAL) INCLUDES:

Air supply grill equipped with vertical and horizontal fins motorised 3D effect - receiver - display

Air intake grill equipped with filter



AD25 - AD35 - AD50 - AD71

1U25- 1U35

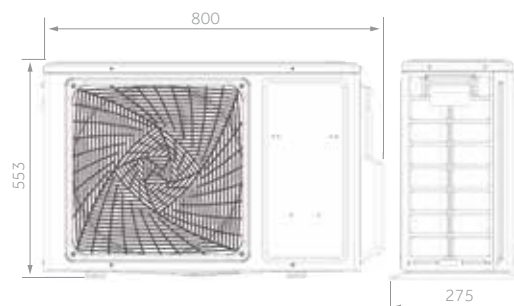
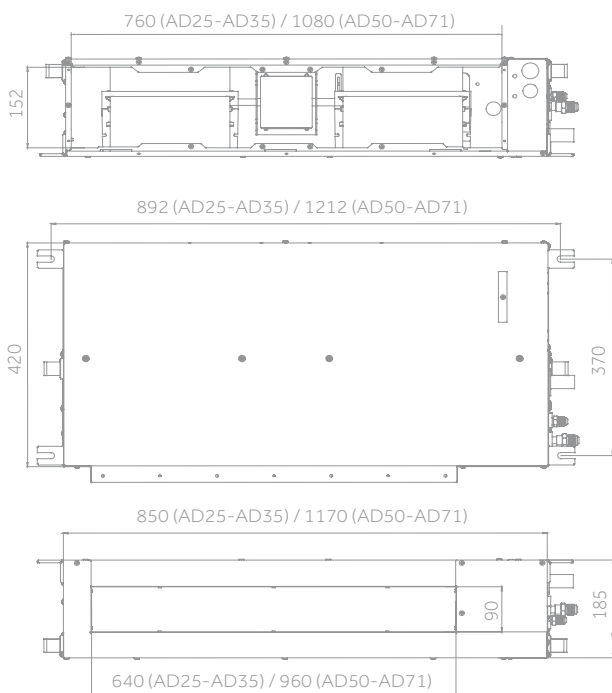

1U50

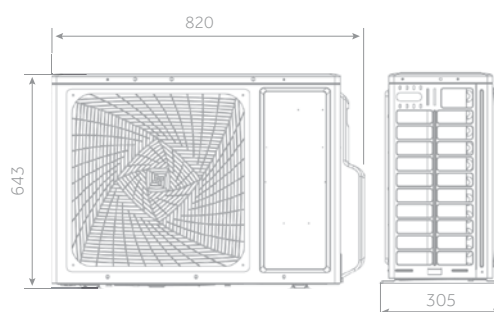

1U71

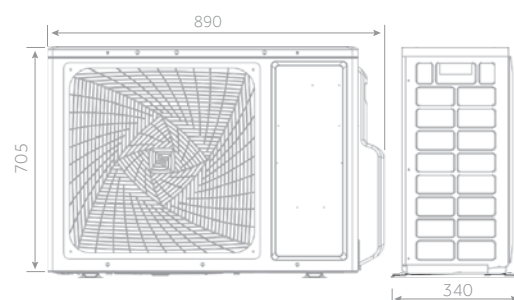

2.5 kW - 3.5kW

5,0kW

7,1kW

SLIM DUCT LOW PRESSURE^{NEW}



A++ / A+

2,5 kW

3,5 kW

5,0 kW

7,1 kW

Please see pages 40 & 41
For Controller Options

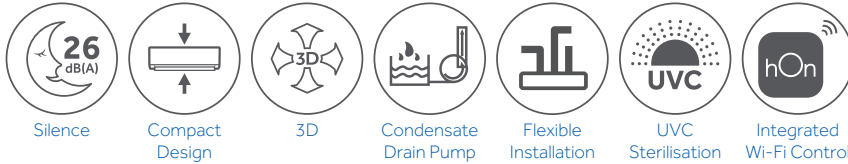

- Low noise level
- Compact design
- Panel kit (OPTIONAL):
air supply and intake grill
- Condensate drain pump
- Flexible installation
- UCV Sterilisation
- Integrated Wi-Fi control

INDOOR UNIT	Model	AD25S2SS1FA(H)	AD35S2SS1FA(H)	AD50S2SS1FA(H)	AD71S2SS1FA(H)	
OUTDOOR UNIT	Model	1U25S2SM1FA-2	1U35S2SM1FA-2	1U50S2S2J2FA-2	1U71S2ST1FA	
Performance data						
Output power - COOLING	nom (min-max) kW	2,5 (0,7-4,3)	3,50 (0,90-4,50)	5,00 (1,80-6,00)	6,8 (2,00-7,30)	
Output power - HEATING	nom (min-max) kW	3,23 (0,9-4,6)	4,00 (1,00-4,80)	5,50 (2,00-6,20)	7,50 (2,50-8,00)	
Absorbed power - COOLING	nom (min-max) kW	0,89 (0,25-1,6)	1,06 (0,28-1,80)	1,53 (0,55-2,10)	2,00 (0,50-2,60)	
Absorbed power - HEATING	nom (min-max) kW	0,87 (0,25-1,6)	1,07 (0,28-1,80)	1,47 (0,60-2,10)	1,97 (0,50-2,60)	
Energy class	EER	W/W	2,8	3,30	3,26	3,4
	COP	W/W	3,71	3,73	3,73	3,8
COOLING Pdesign	35 °C	kW	2,5	3,50	5,00	7,10
HEATING Pdesign	(-10 °C)	kW	2,8	3,00	4,30	5,00
Energy class	SEER		6,10 (A++)	6,10 (A++)	6,10 (A++)	6,10 (A++)
	SCOP		4,00 (A+)	3,80 (A)	4,00 (A+)	4,00 (A+)
Annual Energy Consumption - COOLING	kWh/a	210	241	315	406	
Annual Energy Consumption - HEATING	kWh/a	1398	1427	1961	1831	
Indoor Unit						
Power supply		Ph/V/Hz	1/220-240/50/60	1/220-240/50/60	1/220-240/50/60	1/220-240/50/60
Treated air volume	(H/M/L/Q)	m ³ /h	580/480/380	600/480/420	900/750/600	1000/850/750
External static pressure		Pa	0/10/20/40			
High sound power		dB	50	53	54	59
Sound pressure		dB(A)	32/28/26	33/28/25	36/34/32	46/44/42
Net dimensions	WxDxH	mm	850x420x185	850x420x185	1170x420x185	1170x420x185
Packaging dimensions	WxDxH	mm	1045x530x260	1045x530x260	1365x530x260	1365x530x260
Net/gross weight		kg	16,0/21,0	16,0/21,0	22,8/27,0	25,2/28,4
Panel (optional)	Model		P1B-890IA/D	P1B-890IA/D	P1B-1210IA/D	P1B-1210IA/D
Panel Net dimensions			890x190x100 (outlet panel) 890x290,5x32,4 (inlet panel)		1210x190x100 (outlet panel) 1210x290,5x32,4 (inlet panel)	
Panel Packaging dimensions			938x335x220	938x335x220	1258x335x220	1258x335x220
Panel Net/gross weight			4,0/5,0	4,0/5,0	5,0/6,0	5,0/6,0
Outdoor Unit						
Power supply		Ph/V/Hz	1/220-240/50	1/220-240/50	1/220-240/50	1/220-240/50/60
Power cable		N x mm ²	3 x 1,5	3 x 1,5	3 x 1,5	3 x 4,0
Interconnection cable		N x mm ²	4 x 1,0	4 x 1,0	4 x 1,0	4 x 2,5
Sound power	H	dB	59	61	63	68
Sound pressure	H	dB(A)	47	48	50	54
Running current cooling/heating	Max	A	8,0	8,0	10,68	13,1
Starting current cooling/heating	Max	A	2,0	2,0	2,0	2,0
Net dimensions	WxDxH	mm	800x275x553	800x275x553	820x305x643	890x340x705
Packaging dimensions	WxDxH	mm	902x375x605	902x375x605	940x390x697	1046x460x780
Net/gross weight		kg	27,6/30,4	30,0/32,9	35,7/38,5	44,0/48,0
Compressor type			Rotary inverter	Rotary inverter	Rotary inverter	Twin rotary inverter
Installation data						
Refrigerant			R32	R32	R32	R32
Liquid pipe	∅	mm (inch)	6,35 (1/4)	6,35 (1/4)	6,35 (1/4)	9,52 (3/8)
Gas pipe	∅	mm (inch)	9,52 (3/8)	9,52 (3/8)	12,70 (1/2)	15,88 (5/8)
Standard pipe length without refrigerant charge		m	7	7	7	10
Maximum pipe length		m	20	20	25	50
Maximum IU - OU elevation		m	10	10	15	30
Refrigerant charge in the factory		kg	0,63	0,78	1,10	1,23
Refrigerant charge in the factory		TCO ₂ eq	0,43	0,53	0,74	0,83
Additional ref, charge over std length		g/m	20	20	20	45
Outdoor operating limits - COOLING	min-max	°C		-20-43		-20-46
Outdoor operating limits - HEATING	min-max	°C		-20-24		-20-24