

Detection and Release Devices

F-12-0-001
June 2020

FEATURES

- Repeatable - self-restoring, nothing to replace, testable
- Versatile - various temperature settings available
- Durable - long lasting stainless steel shell
- Economical - wide spacings reduce installation costs
- Factory set
- Internal contact area hermetically sealed in stainless steel shell
- ROHS Compliant

APPLICATIONS

- Protection of schools, factories, offices, libraries, or other non-residential buildings
- Power generation
- Gas station islands
- Paint spray booths
- Range hoods
- Engine compartments



DESCRIPTION

DETECT-A-FIRE® (D-A-F) detectors are the "heart" of many fire protection systems. The highly reliable D-A-F has been the standard for over 75 years. The D-A-F is used for signaling overheat or fire conditions. In the vast majority of applications, the D-A-F provides the initial heat sensing that is used to activate suppression systems using clean agent, CO₂, inert gases, wet or dry chemicals or water.

D-A-F detectors are widely accepted, because they are designed with rate compensation. This provides a unique advantage over both fixed temperature and rate-of-rise types of detectors because the D-A-F detector accurately senses the surrounding air temperature regardless of the fire growth rate. At the pre-determined set point, the system is activated.

Fixed temperature detectors must be completely heated to alarm temperature and therefore a lag in response time may occur with a fast rate fire. Rate-of-rise devices, on the other hand, are triggered by the rate of increase in ambient temperature and are subject to false alarms caused by harmless, transient thermal gradients such as the rush of warm air from process ovens.

The key to the detector's sensitivity is in the design (Figure 1). The outer shell is made of a rapidly expanding alloy which closely follows changes in surrounding air temperature. The inner struts are made of a slower expanding alloy. Designed to resist thermal energy absorption and sealed inside the shell, the struts follow temperature changes more slowly.

A slow rate fire (Figure 2) will heat the shell and struts together. At the "set point", the detector will trigger, actuating the alarm or releasing the extinguishant.

A transient rush of warm air up to 40°F/min. may expand the shell, while not triggering the detector. By ignoring transient warm air excursions, the D-A-F detector virtually eliminates false alarms prevalent with rate-of-rise devices.

If a fast rate fire (Figure 3) starts, the shell will expand rapidly. The struts will close, actuating the alarm and/or releasing the agent. The faster the fire rate of growth, the sooner the D-A-F detector will react.

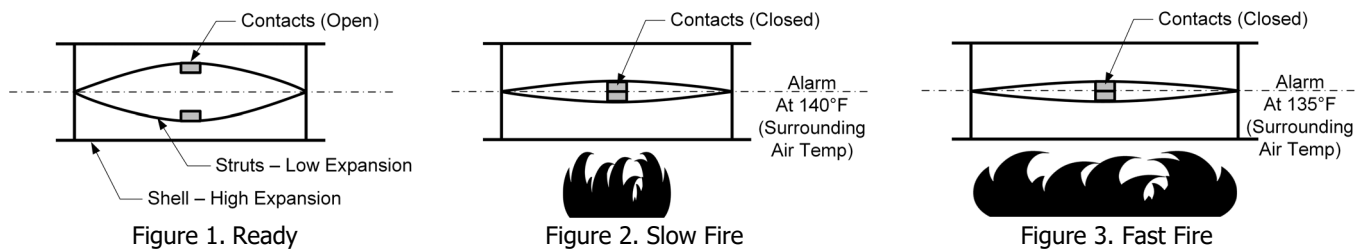

VERTICAL DETECT-A-FIRE DETECTOR SPECIFICATIONS

Vertical D-A-F detectors are designed for use in both "ordinary" or "hazardous" locations. For "ordinary" use, they may be mounted to any approved junction box with 7/8" diameter opening by using 1/2-14 NPT mounting nuts. The device may be wired in or out of conduit, depending on local preferences and codes. To facilitate supervision of system wiring, four lead wires are provided on normally open vertical detectors (that close on temperature rise). When mounted in a appropriately classified mounting box (i.e. Figure 7), detectors are Underwriters Laboratory and Underwriters Laboratory of Canada listed, and FM Approved for hazardous locations.

VERTICAL MODELS

Table 1: Model Numbers 27121, 28021, 27120*, 28020*

°F Setting	°F Tolerance	°C Setting	°C Tolerance	Spacing (in feet)			RTI	Color Coding
				UL	ULC	FM		
140	+7/-8	60	+4/-5	50	50	20	V-Fast	Black
160	+7/-8	71	+4/-5	25	25	20	V-Fast	Black
190	+7/-8	88	+4/-5	50	50	25	V-Fast	White
210	+7/-8	99	+4/-5	25	50	25	V-Fast	White
225	+7/-8	107	+4/-5	25	50	25	V-Fast	White
275	±10	135	±6	25	50	25	V-Fast	Blue
325	±10	163	±6	50	50	25	V-Fast	Red
360	±10	182	±8	25	50	30	V-Fast	Red
450	±15	232	±10	25	50	30	V-Fast	Green
500**	±15	260	±10	50	50	30	V-Fast	Orange
600**	±20	316	±12	N/A	50	30	V-Fast	Orange
725**	±20	385	±12	N/A	50	30	V-Fast	Orange

Notes:

- For clean agents or CO2 suppression systems, ceiling spacing is 20ft. apart unless otherwise specified.
- For NFPA Guidelines on ceiling height compensation, see Table 7.
- *27120 and 28020 are normally closed devices and do not meet the requirements of NFPA-72 for use as initiating devices (they are 2-wire devices).
- *27120 and 28020 are not listed by FM with RTI.
- ** Not available for Normally Closed detectors

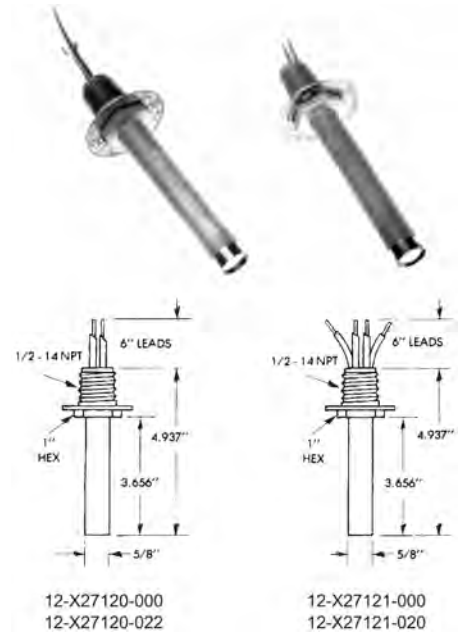

Figure 4. Hexagonal Head

Table 2: Vertical D-A-F Specification

Model Number	Head Material	Contact Operation	Electrical Rating (Resistive Only)
27120-0	Brass	Normally Closed (Open on Rise)	5.0 Amps 125 VAC 0.5 Amps 125 VDC
27120-22	Stainless Steel		
27121-0	Brass	Normally Open (Close on Rise)	5.0 Amps 125 VAC 0.5 Amps 125 VDC 2.0 Amps 24 VDC 1.0 Amps 48 VDC
27121-20	Stainless Steel		
28020-3	Stainless Steel	Normally Closed (Open on Rise)	5.0 Amps 125 VAC 0.5 Amps 125 VDC
28021-5	Stainless Steel	Normally Open (Close on Rise)	5.0 Amps 125 VAC 0.5 Amps 125 VDC 2.0 Amps 24 VDC 1.0 Amps 48 VDC
12-200001-00X*			

Approximate weight: 5 oz. All shell material is Stainless Steel. All Stainless Steel is Type 300.

* Specialty product with limited availability.

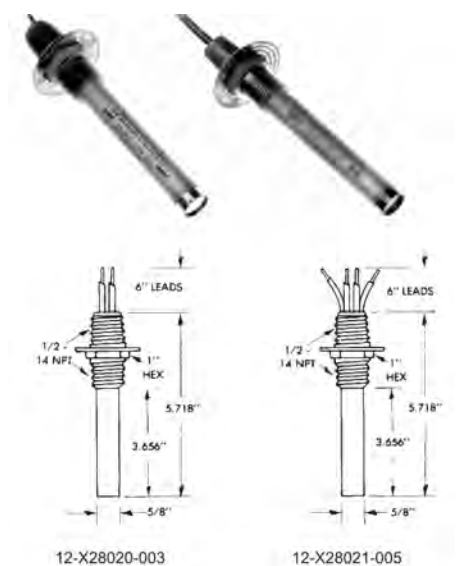

Figure 5. Coupling Head

HORIZONTAL DETECT-A-FIRE DETECTOR SPECIFICATIONS

Horizontal D-A-F detectors are designed for locations where appearance is a factor. The low-profile, functional design lends physical protection of the detector while making it suitable for commercial, industrial, mercantile public buildings, institutions, and marine applications in non-hazardous locations (those classified as "ordinary" under the National Electric Code). Flush mounted detectors are designed to fit standard 4-inch octagonal electric boxes and surface mounting detectors are designed to mount directly on ceilings or on 4-inch electrical junction boxes. Canadian Electrical Codes requires mounting only to an electrical junction box.

Horizontal Models

Table 3: Model Numbers: 27021-0, 27021-1, 27020-0*, 27020-1*

°F Setting	°F Tolerance	Spacing (in feet)			RTI	Color Coding
		UL	ULC	FM		
140	+7/-8	50	50	20	Quick	Black
160	+7/-8	25	25	20	Quick	Black
190	+7/-8	50	50	25	Fast	White
210	+7/-8	25	50	25	Fast	White
225	+7/-8	25	50	25	Fast	White
275	±10	25	50	25	Fast	Blue
325	±10	50	50	25	Fast	Red

- *27020-0 and 27020-1 are normally closed devices and do not meet the requirements of NFPA-72 for use as initiating devices (they are 2-wire devices).
- *27020-0 and 27020-1 are not listed by FM with RTI.

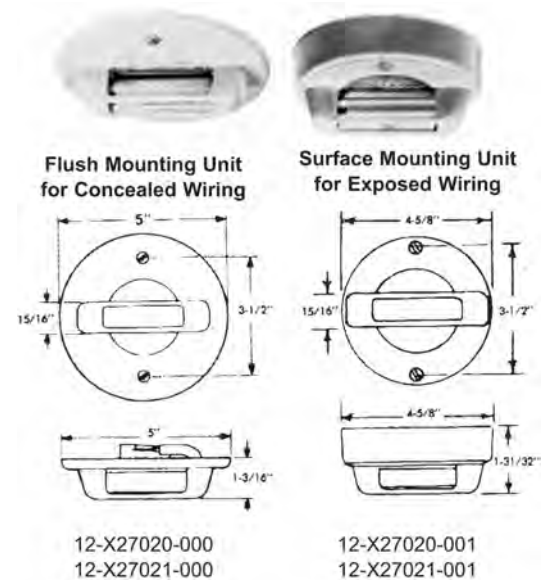

Figure 6. Horizontal Detectors

Note: Horizontal D-A-F detectors are equipped with connector blocks in place of leadwires.

Table 4: Horizontal D-A-F Specifications

Model Number	Mounting Style	Contact Operation	Electrical Rating (Resistive Only)
27020-0	Flush Mount	Normally Closed (Open on Rise)	5.0 Amps 125 VAC 0.5 Amps 125 VDC
27020-1	Surface Mount		
27021-0	Flush Mount	Normally Open (Close on Rise)	5.0 Amps 125 VAC 0.5 Amps 125 VDC 2.0 Amps 24 VDC 1.0 Amps 48 VDC
27021-1	Surface Mount		

Approximate weight: 10 oz.

HORIZONTAL AND VERTICAL DETECT-A-FIRE

Table 5: D-A-F Response Time Index (RTI) and Spacing

Model No.	Configuration	Contact Operation	Temperature (Set Point)	Response Time Index (ft-s) ^{1/2}	RTI Classification	RTI Rated Spacing	Old Rated Spacing
27021-0	Horizontal Flush Mount	Normally Open (Close on Rise)	140°F (60°C), 160°F (71°C)	110	Quick	(20 X 20) ft (6 x 6) m	(25 x 25) ft (8 x 8) m
27021-1	Horizontal Surface Mount						
27021-0	Horizontal Flush Mount	Normally Open (Close on Rise)	190°F (88°C), 210°F (99°C), 225°F (107°C), 275°F (135°C), 325°F (163°C)	140	Fast	(25 x 25) ft (8 x 8) m	(25 x 25) ft (8 x 8) m
27021-1	Horizontal Surface Mount						
27121-0	Vertical Brass Head	Normally Open (Close on Rise)	140°F (60°C), 160°F (71°C), 190°F (88°C), 210°F (99°C), 225°F (107°C), 275°F (135°C), 325°F (163°C), 360°F (182°C), 450°F (232°C), 500°F (260°C), 600°F (316°C), 725°F (385°C)	99 (140°F, 160°F) 148 (190°F, 210°F, 225°F, 275°F, 325°F, 360°F, 450°F, 500°F, 600°F, 725°F)	V-Fast	(30 X 30) ft (9 x 9) m	(25 x 25) ft (8 x 8) m
27121-20	Vertical Stainless Head						
28021-5	Vertical Stainless Coupling Head						

Note: Spaces shown are distances between detectors on smooth ceilings, the distances from partitions or walls would be half that shown. Authority Having Jurisdiction (AHJ) should be consulted before installation.

DETECT-A-FIRE MOUNTING

D-A-F detectors are not position sensitive. Horizontal and vertical detectors refer to the most common mounting configuration for that detector. However each type can be mounted either horizontally or vertically depending on the application and installation requirements.

Table 6: Mounting and Hazardous Location Class

Model Number (Vertical Only)	Hazardous Location	Fitting required for UL & ULC Listing and FM Approval
27120-2 27121-20 28020-3 28021-5	Class I, Groups A, B, C and D; Class II, Groups E, F and G	Mount detector to a suitable listed fitting in accordance with National Electric Code and/or local authority having jurisdiction.
27120-0 27121-0	Class I, Groups B, C and D; Class II Groups E, F and G	

Table 7: Derating Factor for Ceiling Height

Heat Detector Spacing Reduction Based on Ceiling Height				
Ceiling Height Above		Up to and Including		Derating Factor
m	ft	m	ft	
0	0	3.05	10	1.00
3.05	10	3.66	12	0.91
3.66	12	4.27	14	0.84
4.27	14	4.88	16	0.77
4.88	16	5.49	18	0.71
5.49	18	6.10	20	0.64
6.10	20	6.71	22	0.58
6.71	22	7.32	24	0.52
7.32	24	7.93	26	0.46
7.93	26	8.54	28	0.40
8.54	28	9.14	30	0.34

This table outlines the derating factor required depending on ceiling height based on NFPA 72 guidelines for D-A-F detector installation.

CONSTRUCTION

- Stainless steel shell sensing element. Cold rolled steel mounting facility. Off-White finish.
- #18 AWG Teflon™ insulated wire is used on detectors exposed to temperatures up to 375°F.
- #16 AWG TGGT insulated wire is used on detectors exposed to temperatures above 375°F.

MODIFICATIONS

- Add ULC Label to any temperature setting.
- Add fluorocarbon coating for better corrosion resistance on select models and temperatures. (Models 27120-22, 27121-20, 28020-3, 28021-5. Maximum temperature is 500°F.)
- Add extended leadwires on select models and temperatures.

TEMPERATURE SETTING SELECTION

To avoid nuisance activations, Fenwal Controls strongly suggests selecting a D-A-F detector with a temperature setting a minimum of 100°F above the maximum ambient expected temperature.

DEVICE SELECTION

The table below shows three categories of fire detection devices and their relative response levels for reaction to three different rate-of-rise conditions. Consult the AHJ for specific applications.

Table 8: Device Selection for Rate-of-Rise Conditions

Device Type	Under 10°/Min	Between 10-40°/Min	Over 40°/Min
D-A-F Rate Compensated Detector	First	First	Second but at selected protection level
Fixed Temp. Detector	Second	Second	Third
Rate-of-Rise Detector	Third	Third	First but may be a false alarm

AGENCY LISTINGS

D-A-F detectors are UL and ULC listed and FM Approved as fire detection thermostats (close on temperature rise) and as releasing devices (open on temperature rise).

Table 9: Agency Approvals

Agency	File Number	Location
UL	S492	Ordinary
UL	E19310	Hazardous
ULC	CS341-E	Ordinary and Hazardous
FM	J.I. OV2HO.AE	Hazardous
FM	17302	Ordinary
UL	S2410	Ordinary (600 & 725°F)
UL	E89599	Hazardous (600 & 725°F)
CE	IEC 60947-5-1	—

NOTES:

- D-A-F detectors are temperature preset at the factory.
- For corrosive environments, care should be taken to protect the D-A-F detector to obtain optimal performance and maximum life. Consult factory for fluorocarbon coating option.
- For field wiring requirements to connect to D-A-F, please refer to the installation instructions.
- Per UL521 requirements - low temperature exposure test is - 22°F (-30°C)
- D-A-F detectors are designed for long life expectancy, however due to various field conditions it is required that the detectors be tested annually per NFPA guidelines or local fire codes.
- Replace D-A-F detector after any fire or heat related event, any mechanical damage, or after 10 years of continuous service.
- D-A-F detectors are CE Listed. The product family has been evaluated in accordance with IEC 60947-1 and IEC 60947-5- 1, and is documented under Intertek Report No. 102294754 BOX-001 as an overheat detector. Detectors have a rated insulation and impulse voltages of 1500 VAC.

DETECT-A-FIRE MOUNTING BOX

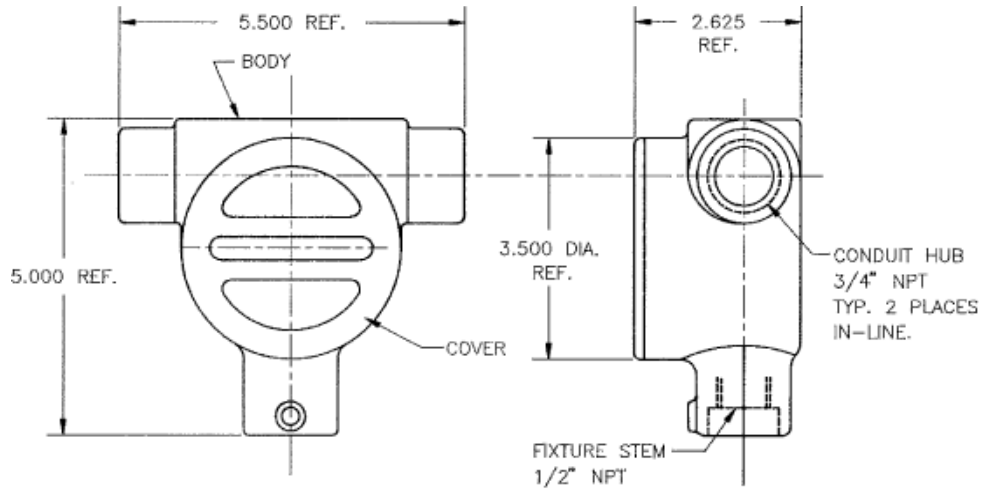

Figure 7. Optional Explosion Proof Mounting Box,
P/N 06-116317-001

Note: Figure 7. Complies with NEC Class I, Groups A, B, C, D, Class II, Group E,F,G, Class III, and U.L. Standard 1203. Explosion Proof Mounting Box must be purchased separately from the D-A-F.

HOW TO ORDER

1. Select a D-A-F model from specifications in Table 2 for vertical design or Table 4 for horizontal design.
2. Select a temperature rating from Table 1 for vertical design or Table 3 for horizontal design.

Note: To avoid nuisance activations, Fenwal Controls strongly suggests selecting a D-A-F detector with a temperature setting a minimum of 100°F above the maximum ambient expected temperature.

3. Optional, select item from the Modifications Section. Consult Fenwal Controls to ensure modifications are available on the selected model.

Example: **27121-20** at **190°F** with **Fluorocarbon Coating**

Table 10: Stocked Models and Temperature Settings

Model	Style	Contact Type	Temperature Setting (°F)												
			140	160	190	210	225	275	325	360	450	500	600	725	
27020-0	Horizontal, Flush Mount	NC	S		S						N/A	N/A	N/A	N/A	N/A
27020-1	Horizontal, Surface Mount	NC	S								N/A	N/A	N/A	N/A	N/A
27021-0	Horizontal, Flush Mount	NO	S		S			S			N/A	N/A	N/A	N/A	N/A
27021-1	Horizontal, Surface Mount	NO	S		S						N/A	N/A	N/A	N/A	N/A
27120-0	Vertical, Brass Head	NC	S	S	S			S		S				N/A	N/A
27120-22	Vertical, Stainless Steel	NC	S		S			S						N/A	N/A
27121-0	Vertical, Brass Head	NO	S	S	S	S	S	S	S	S	S	S	S	S	S
27121-20	Vertical, Stainless Steel	NO	S	S	S			S	S	S		S		S	
28021-5	Vertical, Coupling Head	NO			S			S		S	S	S			

S - Stocked D-A-F detector available for quick delivery of a limited quantity. Other models and variations are manufactured on demand.

EXPORT INFORMATION (USA)

DETECT-A-FIRE is a registered trademark of Kidde-Fenwal, Inc., or its parents, subsidiaries, or affiliates. All other trademarks are the property of their respective owners.

Jurisdiction: EAR
Classification: EAR99
This document contains technical data subject to the EAR.

FENWAL
CONTROLS

Fenwal Controls; Kidde-Fenwal, Inc.
400 Main Street
Ashland, MA 01721
Tel: 1-800-FENWAL-1
Fax: 508-881-7619
fenwalcontrols.com

This literature is provided for informational purposes only. KIDDE-FENWAL, INC. assumes no responsibility for the product's suitability for a particular application. The product must be properly applied to work correctly. If you need more information on this product, or if you have a particular problem or question, contact KIDDE-FENWAL, INC., Ashland, MA 01721.

SERIES 27000

Horizontal DETECT-A-FIRE® Units Installation Instructions



12.02.E

Model Number	Contact Operation on Temperature Rise	Electrical Rating* (Resistive Only)
12-X27020-0	Opens	5.0 Amps 125 VAC 0.5 Amps 125 VDC
12-X27020-1		
12-X27021-0	Closes	5.0 Amps 126 VAC 0.5 Amps 125 VDC 2.0 Amps 24 VDC 1.0 Amps 48 VDC
12-X27021-1		

Note: *Although incandescent lamps are considered resistive, their inrush current is 10-15 times their steady current. Do not exceed ratings.

LOCATION

DETECT-A-FIRE® detectors are precision temperature sensors. They must be mounted in an area (normally a ceiling) so that:

1. The detector spacing complies with both system requirements and requirements of the agency having local jurisdiction.
2. The thermal air path to the shell is not obstructed.

Spacing per UL, FM, and UL of Canada is show in Table 1. Distances given are for between units on smooth ceilings. Distances from partitions or walls are half that shown. To assume that all spacing requirements are met, consult the authority having local jurisdiction.

MOUNTING

DETECT-A-FIRE units are not position sensitive. Horizontal and vertical detectors refer to the most common mounting configurations for that unit. However, each type can be mounted either horizontally or vertically depending on the application and installation requirements.

TABLE 1: Model Number 12-X27020*, 12-X27021

X	°F Setting	°F Tolerance	Spacings (in feet)			RTI	Color Coding
			UL	ULc	FM		
A	140	+7/-8	50	50	20	Quick	Black
A	160	+7/-8	25	25	20	Quick	Black
A	190	+7/-8	50	50	25	Fast	White
A	210	+7/-8	25	50	25	Fast	White
A	225	+7/-8	25	50	25	Fast	White
B	275	±10	25	50	25	Fast	Blue
B	325	±10	50	50	25	Fast	Red

Notes:

- For clean agents and CO2 suppression systems, ceiling spacing is 20 ft. apart unless otherwise specified.
- 27120 is a 2-wire device and RTI is not applicable.
- 27120 is a normally closed device and does not meet the requirements of NFPA-72 for use as an initiating device.

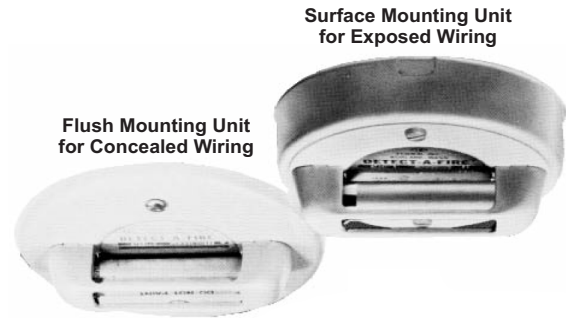

INSTALLATION

Figure 1. Surface Mount Units (Series 27020-1 and 27021-1)

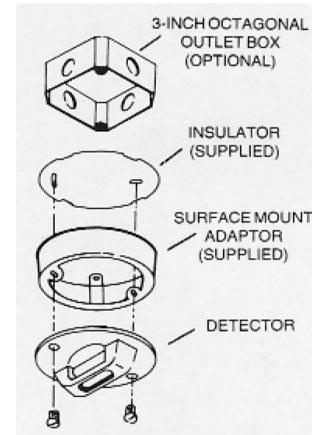

These detectors are provided with a surface mount adaptor which may be mounted on a ceiling or to an outlet box. However, if the adaptor is direct ceiling mounted, CIRCUIT VOLTAGE MUST BE LIMITED TO 30 VOLTS.

The Canadian Electrical Code, Part 1, requires that these devices be installed, mounted to an approved outlet box and connected to Class 1 wiring. Surface mount units shall be used only in this manner for Canadian approval.

For direct ceiling mount, proceed as follows:

1. The knockouts are located on the side of the surface mount adaptor. Remove appropriate knockouts and install rubber grommets.
2. Mount adaptor to solid ceiling surface through slotted hole in adaptor mounting brackets. Supplied insulator gasket should be placed between ceiling and adaptor. Adaptor may be rotated to position detector.
3. Run system wiring through rubber grommets and connect to terminals on detector per Figure 3 observing applicable electrical codes.
4. Mount detector to adaptor with two #8-32 screws supplied.

INSTALLATION (CONTINUED)

For optional outlet box mount, proceed as follows:

1. Bend the mounting brackets on the supplied adaptor to fit standard 4-inch outlet box.
2. Mount adaptor to outlet box through slotted holes in adaptor mounting brackets. Adaptor may be rotated to position detector.
3. Connect system wiring to terminals on detector per Figure 3 observing applicable electrical codes.
4. Mount detector to adaptor with two #8-32 screws supplied.

**Figure 2: Flush Mount Units
(Series 12-X27020-0 and 12-X27021-0)**

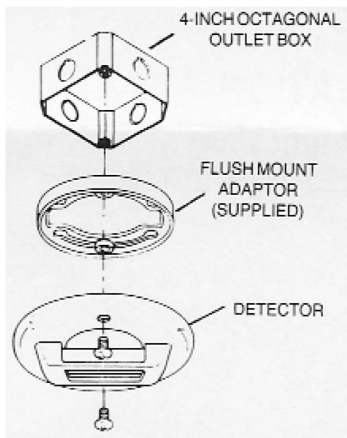

1. It is recommended that a standard 4-inch outlet box be used to mount the detector. Care should be taken that a neat 4-inch diameter hole be cut in ceiling to allow mounting clearance for detector. An oversized or ragged hole may show around the mounted unit.
2. Attach supplied flush mount adaptor to outlet box. Adaptor may be rotated in screw slots to position detectors as desired.
3. Connect system wiring to terminals on detector per Figure 3 observing applicable electrical codes.
4. Mount detector to adaptor with two #8-32 screws supplied.

DETECT-A-FIRE is a registered trademark of Kidde-Fenwal, Inc., or its parents, subsidiaries, or affiliates. Kidde is a registered trademark of Kidde-Fenwal, Inc., or its parents, subsidiaries, or affiliates.

Specifications are subject to change without notice. This literature is provided for informational purposes only. KIDDE-FENWAL, INC. assumes no responsibility for the product's suitability for a particular application. The product must be properly applied to work correctly. If you need more information on this product, or have a particular problem or question, contact KIDDE-FENWAL, INC.

Figure 3: System Wiring

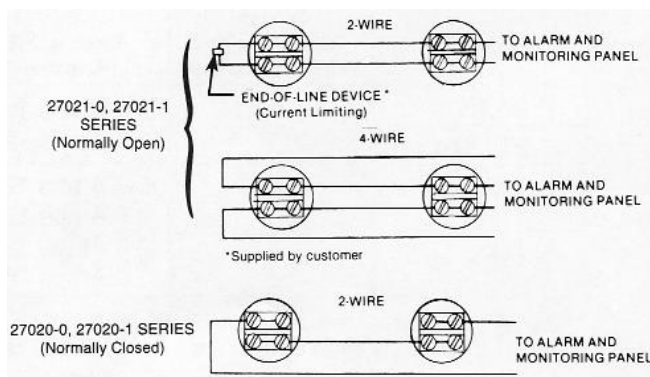

1. In order to function properly, the sensing shell of the unit must remain free from paint, grease, oil, etc. Should such a build up occur, DO NOT, under any circumstances, attempt to remove it. Replace the unit.
2. Detectors mounted in an area subject to physical abuse or damage, must be suitably protected without obstructing the thermal airpath to the unit.
3. Do not install the unit where the shell would be physically damaged by sand, grain, rocks, etc.
4. Any detector that has been involved in a fire or damaged must be replaced.
5. Consult the factory for special precautions necessary for outdoor use or moist environments.



ANY OF THE ABOVE COULD CHANGE THE FACTORY TEMPERATURE SETTING, WHICH MAY RESULT IN PROPERTY DAMAGE AND/OR PERSONAL INJURY OR DEATH.

IT IS POSSIBLE FOR A UNIT TO HAVE BEEN ABUSED OR DAMAGED AND NOT DISPLAY ANY OUTWARD INDICATION OF THE DAMAGE. ALL UNITS SHOULD BE TESTED PERIODICALLY IN ACCORDANCE WITH NATIONAL FIRE PROTECTION ASSOCIATION REQUIREMENTS (72e) OR THE AGENCY HAVING LOCAL JURISDICTION.

EXPORT INFORMATION (USA)

Jurisdiction: EAR

Classification: EAR99

This document contains technical data subject to the EAR.

TECHNICAL ARTICLE

DETECT-A-FIRE[®] Test Procedures

VISUAL INSPECTION

As part of the recommended maintenance procedure, perform a visual inspection of the DETECT-A-FIRE[®] unit in accordance with NFPA 72 guidelines. During the visual inspection, verify that the sensing shell is free of dents, dings or build up of foreign matter of any kind. If the shell is dented or shows signs of any physical damage, replace the unit immediately. If a build up of dust has accumulated on the unit, clean the unit with a vacuum or soft dry cloth. If the shell has been painted, replace the unit. Be careful not to damage the unit in any way.

Note: Some units are factory coated. Do not confuse these with units that were painted by the owners.

OPERATIONAL VERIFICATION

Perform the following to verify the operation of the DETECT-A-FIRE unit:

1. Disconnect the unit from the system.
2. Using a a heat gun, hair dryer, or similar heat source, apply heat evenly to the complete sensing shell. The heated air temperature must be above the alarm set point temperature of the unit.

Note: Depending on the model type, the internal contacts will either close or open which can be verified with a standard OHM meter. Remove the heat immediately after activation.

FUNCTIONAL TEST

If the DETECT-A-FIRE unit is used with automatic fire extinguishing systems, perform the following functional test:

1. Disconnect the initiator/solenoid leads from the panel.
2. Connect a 24 VDC bulb to the initiator terminals in the control unit.
3. Using a a heat gun, hair dryer, or similar heat source, heat the unit.
4. When the bulb in the control unit changes state, remove the heat source and allow the unit to cool.
5. Reset the control unit. The test lamp must change state and stay changed after the system is reset.

Note: Do not reconnect initiator/ solenoid leads until all DETECT-A-FIRE units have cooled below the set point as indicated by test lamp.

(Continued in next column)

DETECT-A-FIRE is a registered trademarks of Kidde-Fenwal, Inc., or its parents, subsidiaries or affiliates. All other trademarks are the property of their respective owners.

FUNCTIONAL TEST (CONTINUED)

When DETECT-A-FIRE units are used in other types of systems, perform the following functional test:

1. Disconnect the unit from the system.
2. Connect a 24 VDC lamp and power source in series with the units.
3. Using a a heat gun, hair dryer, or similar heat source, heat the unit.
4. When the bulb in the control unit changes state, remove the heat source and allow the unit to cool.

Note: Make sure that contacts have reset to normal condition before reconnecting to system circuit.

CALIBRATION VERIFICATION

Accurately recording the temperature setting of a DETECT-A-FIRE unit requires a special calibration test kit. A test kit with an aluminum block is required as it simulates factory test equipment. Heat transfer mediums such as liquid and air, or test equipment such as air, liquid or sand baths are not recommended for temperature verification. Please contact technical support at 1-800-FENWAL-1 for information on suitable test kits.

WARNINGS

- **DO NOT** overshoot the set point of the unit by more than 100°F (55°C), this could result in a shift of the set point temperature.
- **DO NOT** contact the sensing shell with a heating device such as a soldering iron or blowtorch as this will damage the unit and cause a shift in the set point temperature.
- **IT IS ABSOLUTELY ESSENTIAL** that the deluge systems be disengaged prior to any tests.
- The calibration verification procedures pertain only to the Fenwal Controls DETECT-A-FIRE Vertical (Probe) type, models 2712X-XX and 2802X-X. Horizontal type models, 2702X-X must be verified at the factory.
- While the DETECT-A-FIRE unit is a self resetting device, replacement is recommended should the unit be subjected to the intense heat of a fire.

ANY OF THE ABOVE COULD CHANGE THE FACTORY TEMPERATURE SETTINGS, WHICH MAY RESULT IN PROPERTY DAMAGE AND/OR PERSONAL INJURY OR DEATH. IT IS POSSIBLE FOR A UNIT TO HAVE BEEN ABUSED OR DAMAGED AND NOT DISPLAY ANY OUTWARD INDICATION OF THE DAMAGE. ALL UNITS SHOULD BE TESTED PERIODICALLY IN ACCORDANCE WITH NATIONAL FIRE PROTECTION ASSOCIATION REQUIREMENTS (72E) OR THE AUTHORITY HAVING LOCAL JURISDICTION.

PREFACE

Traditionally there are two types of heat detectors: fixed temperature and rate-of-rise. There may be circumstances where neither of these methods is optimal and another method is needed. The Fenwal Controls rate-compensated heat detector has unique characteristics that may make it ideal in your situation. This document explains the principles of the Detect-A-Fire® (D-A-F) rate compensated heat detector.

Fixed Temperature

Fixed temperature devices activate when the entire detector unit is completely heated to the operating temperature. Under fast rate fire conditions and sudden temperature rise, there could be a lag in response time before some types of fixed temperature detectors have fully heated and activate.

Rate-of-Rise

Rate-of-Rise devices activate when ambient temperature increases at a predetermined rate (typically 15°F per minute). False alarms can happen when there is a sudden rush of heated air such as the rush of warm air from process ovens when doors open. These types of devices may also fail to activate if there is steady but slow rise in heat below the 15°F per minute rate, such as in a smoldering fire.

Combination Fixed & Rate-of-Rise

A combination of both technologies can also be unreliable. An example of this would be if you had a temperature increase of 10°F per minute. This would be slow enough to not trigger the rate of rise activation and still be fast enough to cause a lag in activation.

Rate Compensated

Rate compensated devices such as the D-A-F act as a fixed temperature device that compensates for both ambient temperature changes and fast rate-of-rise situations. This design allows the detector to “anticipate” fire conditions and thus activate before the fixed temperature is reached in a fast fire. The functionality of the detector is generally not affected by transient temperature changes when being installed in typical outdoors environments where the temperature can vary from extreme cold to warm and will reliably activate at it’s designed fixed temperature.

PRINCIPLES of OPERATION

Design

The D-A-F's inner assembly has silver electrical contacts that are mounted on, but electrically insulated from, two curved struts which have a low coefficient of expansion. This assembly is mounted under compression inside an outer stainless-steel shell which has higher coefficient of expansion than the inner struts. The unit is then calibrated and hermetically sealed at the factory.



Figure 1 – Cutaway of Typical D-A-F

Operation

The inner struts and the outer shell expand at different rates, this creates two variables that affect when the contacts will mate and activate the detector. An increase in temperature causes the shell to expand decreasing compression on the struts bringing the contact closer together. That same increase in temperature on the inner struts causes them to expand and become farther apart.

In a very slow rate of rise condition, about 1°F per minute, the unit heats up evenly throughout. This results in both the shell and internal strut assembly expanding to the point where the unit operates close to its set point temperature.

In faster rate of rise conditions, the outer shell expands faster than the internal strut assembly. This causes the anticipation or rate-compensation effect allowing the detector to activate even though the temperature may be below the set point.

The D-A-F detectors are optimized to work in situations where the rate of rise is between 10°F and 40°F per minute. An increase in heat greater the 40°F per minute is usually classified as explosive.

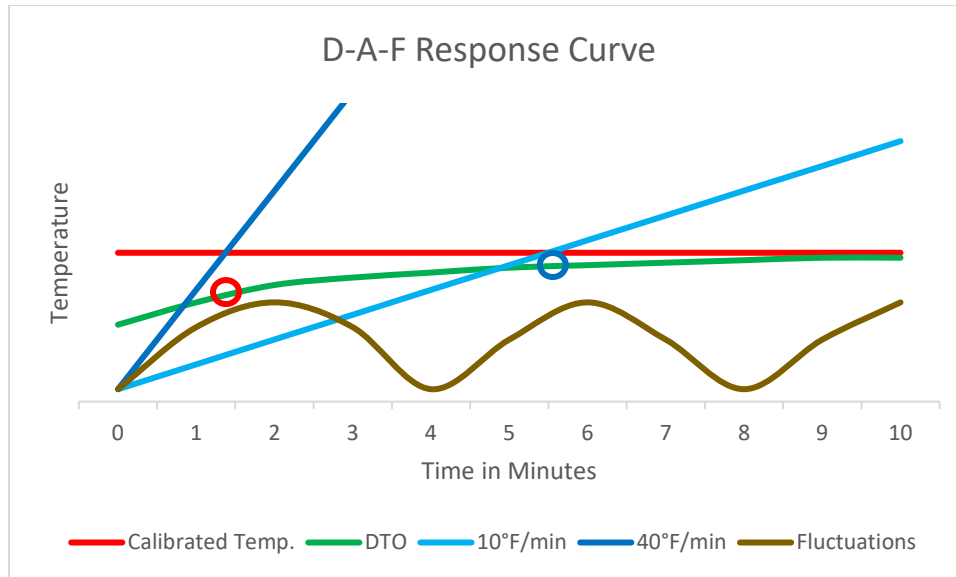

Figure 2 – Response Curve

D-A-F Response

In figure 2, the red line represents the calibrated temperature of the D-A-F. The dark blue line is a temperature rise of 40°F/min while the light blue line is a rise of 10°F/min, most typical fires fall within this range. The green line represents the device temperature at operation (DTO) which you can see is lower than the calibrated temperature as part of the rate compensated design. The faster the rate of rise, the lower the temperature the D-A-F activates.

In reviewing figure 2, you can see that in a rate of rise condition of 40°F/min, that the D-A-F is activating approximately 10% below the calibrated activation temperature (noted by the red circle). The D-A-F activates in anticipation of the activation temperature because the surrounding air heats faster than the internal strut assembly of the D-A-F.

Additionally, in reviewing figure 2, you can see that in a rate of rise condition of 10°F/min, that the D-A-F is still activating below the calibrated activation temperature (noted by the blue circle). The D-A-F is still anticipating the activation temperature but by a smaller percentage because the internal strut assembly of the DAF more closely matches the air temperature.

The brown line in figure 2 represents fluctuations in air temperature that can be caused by exposure to the sun or heat from an oven door being opened. A typical rate of rise detector may activate due to the sudden change of temperature, but the D-A-F will not activate if the temperature is safely below the calibrated activation temperature. Fenwal Controls recommends the activation temperature to be 100°F above the normal maximum ambient temperature.

Calibration, Verification, and Testing

At the factory, calibration of the D-A-F starts by placing the uncalibrated units into a temperature controlled heat block and preheating them at the calibration set temperature for 45 minutes. The system then performs an initial setting to the calibration temperature. The units are then “burned-off” by sending a 10A current at 24VAC through the electrical contacts for 6 cycles of open and close of the circuit, this cleans the electrical contacts inside the D-A-F. The units are then calibrated to the set temperature of the heat block and allowed to cool off to room temperature.

Verification of the D-A-F calibration is completed in a separate automated test system that utilizes a single station aluminum heat block for each unit. The power to the heater internal to the heat block is controlled by the switch contacts of the unit itself and monitored electronically through the automated test system. The power to the heater is set dependent on the unit’s set temperature in order to achieve the ideal “50% on - 50% off duty cycle”. This means that the block’s heat and cool cycle is measured to be the same time with the unit heating up and cooling down at roughly the same time interval. This process is repeated 10 times to stabilize the product and then another 5 times for the official verification of calibration. The final 5 actuation temperatures are then recorded and the average of the 5 readings is then compared to the set temperature and required tolerance. If the unit is outside the required tolerance, the D-A-F is rejected. The final 5 actuation temperatures are also compared from cycle to cycle for repeatability. If the cycle temp varies by more than 3 degrees from one cycle to the next cycle, the D-A-F is rejected.

Note: It is important to know that heat transfer varies by medium and using air or oil will provide different results than the aluminum block used at our factory.

Since it is difficult to test in a manner similar to the factory, we recommend when testing to always ensure that you are heating slower than the 1°F per minute or your results will be affected by the anticipation factor of the D-A-F.



Fenwal Controls, Kidde-Fenwal Inc.
400 Main Street
Ashland, MA 01721
Tel: 800-FENWAL-1
Fax: 508-881-7619
fenwalcontrols.com

This literature is provided for informational purposes only. KIDDE-FENWAL, INC. assumes no responsibility for the product's suitability for a particular application. The product must be properly applied to work correctly. If you need more information on this product, or if you have a particular problem or question, contact KIDDE-FENWAL, INC., Ashland, MA 01721.