

BIT25 INSTRUCTIONS FOR USE

Thank you for having chosen an LAE electronic product. Before installing the instrument, please read this instruction booklet carefully in order to ensure safe installation and optimum performance.

DESCRIPTION



Fig.1 - Front panel

- Info / Setpoint button.
- Manual defrost / Decrease button.

INDICATIONS

- Thermostat output
- Fan output
- Defrost output
- Activation of 2nd parameter set
- Alarm
- Increase button / Manual activation.
- Exit / Stand-by button.

INSTALLATION

- The BIT-25 controller has a size 86x82x44 mm (WxHxD).
- Make sure that electrical connections comply with the paragraph "wiring diagrams". To reduce the effects of electromagnetic disturbance, keep the sensor and signal cables well separate from the power wires.
- Place the probe T1 inside the room in a point that truly represents the temperature of the stored product.
- If present, place the probe T2 on the evaporator where there is the maximum formation of frost.
- If probe T3 is connected to DI2, its function is determined by the parameter T3M. With T3M=DSP the probe measures the temperature to be displayed. With T3M=CND the probe measures the condenser temperature, it must therefore be placed between the fins of the condensing unit.

OPERATION

DISPLAY

During normal operation, the display shows either the temperature measured or one of the following indications:

dEF	Defrost in progress	h _i	Room high temperature alarm
oFF	Controller in stand-by	L _o	Room low temperature alarm
cL	Condenser clean warning	E ₁	Probe T1 failure
d _o	Door open alarm	E ₂	Probe T2 failure
h _c	Condenser high temperature alarm	E ₃	Probe T3 failure
ALr	Generic Alarm		

INFO MENU

The information available in this menu is:

t ₁	Instant probe 1 temperature	t _{L_o}	Minimum probe 1 temperature recorded
t ₂ *	Instant probe 2 temperature	cnd**	Compressor working weeks
t ₃ *	Instant probe 3 temperature	Loc	Keypad state lock
t _h	Maximum probe 1 temperature recorded		

*: displayed only if enabled (see §Configuration Parameters) ** : displayed only if ACC > 0

Access to menu and information displayed.

- Press and immediately release button **I**.
- With button **▼** or **▲** select the data to be displayed.
- Press button **I** to display value.
- To exit from the menu, press button **⊗** or wait for 10 seconds.
- Reset of THI, TLO, CND recordings**
- With button **▼** or **▲** select the data to be reset.
- Display the value with button **I**.
- While keeping button **I** pressed, use button **⊗**.

SETPOINT : display and modification

- Press button **I** for at least half second, to display the setpoint value.
- By keeping button **I** pressed, use button **▼** or **▲** to set the desired value (adjustment is within the minimum SPL and the maximum SPH limit).
- When button **I** is released, the new value is stored.

STAND-BY

Button **⊗**, when pressed for 3 seconds, allows the controller to be put on a standby or output control to be resumed (with **SB**=YES only).

KEYPAD LOCK

The keypad lock avoids undesired, potentially dangerous operations, which might be attempted when the controller is operating in a public place. In the INFO menu, set parameter **LOC**=YES to inhibit all functions of the buttons. To resume normal operation of keypad, adjust setting so that **LOC**=NO.

SELECTION OF SECOND PARAMETER GROUP

It's possible to select control parameters between two different pre-programmed groups, in order for the fundamental control parameters to be adapted quickly to changing needs. Changeover from Group I to Group II (and vice versa) may take place MANUALLY by pressing button **M** for 2 seconds (with **IISM**=MAN), or AUTOMATICALLY when **IISM**=DI2 and the AUXILIARY INPUT DI2 is activated (the activation of DI2 selects Group II). If **IISM**=NON, switchover to Group II is inhibited. The activation of Group II is signalled by the lighting up of the relevant LED on the controller display.

SETPOINT ADJUSTMENT VIA POTENTIOMETER

With **DI2**=SET the setpoint is set via a 10KΩ potentiometer connected to DI2. The setpoint changes between **SPL** (10KΩ) and **SPH** (0Ω) proportionally. With **SB**=YES, **SPH** matches 2KΩ and for values lower than this the controller is set to standby. If the second parameter group is active, the setpoint used will be **IISP**.

DEFROST

Automatic defrost. Defrost starts automatically when the defrost timer matches the time value set with **DFT**.

- Timed defrost.** With **DFM**=TIM defrosts take place at regular intervals of **DFT** hours. For example, with **DFM**=TIM and **DFT**=06, a defrost will take place every 6 hours.
- Optimized defrost.** With **DFM**=FRO the timer is increased only when the condition for frost to form in the evaporator occurs. Once the **DFT** value is reached, defrost takes place. If the evaporator works at 0°C, defrost frequency depends on the thermal load and climatic conditions. With setpoints much lower than 0°C, defrost frequency mainly depends on the refrigerator operating time.
- Defrost time count backup.** At the power-up, if **DFB**=YES, the defrost timer resumes the time count from where it was left off before the power interruption. Vice versa, with **DFB**=NO, the time count re-starts from 0. In stand-by, the accumulated time count is frozen.
- Manual or remote defrost start.** It's possible to manually start a defrost, by pressing button **⊗** for 2 seconds, or defrost may be started remotely, if **DI1**=RDS (**DI2**=RDS), through the making of the auxiliary contact DI1 (DI2).

Defrost type. Once defrost has started, Compressor and Defrost outputs are controlled according to parameter **DTY**. If **FID**=YES, the evaporator fans are active during defrost.

Defrost termination. The actual defrost duration is influenced by a series of parameters.

- Time termination:** **T2**=NO, the evaporator temperature is not monitored and defrost will last as long as time **DTO**.
- Temperature termination:** **T2**=YES. In this case, if the sensor T2 measures the temperature **DLI** before the time **DTO** elapses, defrost will be terminated in advance.

Resuming thermostatic cycle. When defrost is over, if **DRN** is greater than 0, all outputs will remain off for **DRN** minutes, in order for the ice to melt completely and the resulting water to drain. Moreover, the fans will re-start only when the evaporator temperature is lower than **FDD** (if **T2**=YES), or after **FTO** minutes have elapsed.

Caution: if **DFM**=NON all defrost functions are inhibited; if **DFT**=0, automatic defrost functions are excluded; during a high pressure alarm or a DI1 (DI2) generic alarm, defrost is suspended; during defrost, high temperature alarm is bypassed.

CONFIGURATION PARAMETERS

- To get access to the parameter configuration menu, press button **⊗** + **I** for 5 seconds.
- With button **▼** or **▲** select the parameter to be modified.
- Press button **I** to display the value.
- By keeping button **I** pressed, use button **▼** or **▲** to set the desired value.
- When button **I** is released, the newly programmed value is stored and the following parameter is displayed.
- To exit from the setup, press button **⊗** or wait for 30 seconds.

PAR	RANGE	DESCRIPTION
SPL	-50...SPH	Minimum limit for SP setting.
SPH	SPL...110°C	Maximum limit for SP setting.
SP	SPL... SPH	Setpoint (value to be maintained in the room).

HYS	1.0...10.0°C	OFF/ON thermostat differential.
CRT	0...30min	Compressor rest time. The output is switched on again after CRT minutes have elapsed since the previous switchover. We recommend to set CRT=03 with HYS<2.0°.
CT1	0...30min	Thermostat output run when probe T1 is faulty. With CT1=0 the output will always remain OFF.
CT2	0...30min	Thermostat output stop when probe T1 is faulty. With CT2=0 and CT1>0 the output will always be ON. <i>Example:</i> CT1=4, CT2= 6. In case of probe T1 failure, the compressor will cycle 4 minutes ON and 6 minutes OFF.
CSD	0...30min	Compressor stop delay after the door has been opened (active only if D1=DOR or DI2=DOR).
DFM	NON; TIM; FRO	Defrost start mode NON : defrost function is disabled (<i>the following parameter will be</i> FCM). TIM : regular time defrost. FRO : the defrost time count is only increased when the conditions occur for frost to form on the evaporator (optimised time increase).
DFT	0...99 hours	Built-in timer value for an automatic defrost to take place.
DFB	NO/YES	Defrost timer backup. With DFB=YES, after a power interruption, the timer resumes the count from where it was left off with ±30 min. approximation. With DFB=NO, after a power interruption, the defrost timer will re-start to count from zero.
DLI	-50...110°C	Defrost end temperature.
DTO	1...120min	Maximum defrost duration.
DTY	OFF; ELE; GAS	Defrost type OFF : off cycle defrost (Compressor and Heater OFF). ELE : electric defrost (Compressor OFF and Heater ON). GAS : hot gas defrost (Compressor and Heater ON).
DPD	0...240sec	Evaporator pump down. At the beginning of defrost, defrost outputs (determined by DTY) are OFF for DPD seconds.
DRN	0...30min	Pause after defrost (evaporator drain down time).
DDM	RT; LT; SP; DEF	Defrost display mode. During defrost the display will show: RT : the real temperature; LT : the last temperature before defrost; SP : the current setpoint value; DEF : "dEF".
DDY	0...60min	Display delay. The display shows the information selected with parameter DDM during defrost and for DDY minutes after defrost termination.
FID	NO/YES	Fans active during defrost.
FDD	-50...110°C	Evaporator fan re-start temperature after defrost (referred to T2 probe).
FTO	0...120min	Maximum evaporator fan stop after defrost.
FCM	NON; TMP; TIM	Fan mode during thermostatic control. NON : The fans remain ON all the time; TMP : Temperature-based control. The fans are ON when the compressor is ON. When the compressor is turned OFF, the fans remain ON as long as the temperature difference T2-T1 is greater than FDT. The fans are turned ON again with FDH differential. (T1 = Air temperature, T2 = Evaporator temperature); TIM : Timed-based control. The fans are ON when the compressor is ON. When the compressor is OFF, the fans switch ON and OFF according to parameteres FT1, FT2, FT3.
FDT	-12.0...0.0°C	Evaporator-Air temperature difference for the fans to turn OFF after the compressor has stopped.
FDH	1.0...12.0°C	Temperature differential for fan re-start. <i>Example:</i> FDT = -1.0, FDH=3.0. In this case, after the compressor has stopped, the fans are OFF when T2 > T1 - 1.0 (FDT), whereas the fans are ON when T2 < T1 - 4.0 (FDT-FDH).
FT1	0...180sec	Fan stop delay after compressor stop.
FT2	0...30min	Timed fan stop. With FT2=0 the fans remain on all the time.
FT3	0...30min	Timed fan run. With FT3=0, and FT2 > 0, the fans remain off all the time.
ATM	NON; ABS; REL	Alarm threshold management. NON : all temperature alarms are inhibited (<i>the following parameter will be</i> ADO). ABS : the values programmed in ALA and AHA represent the real alarm thresholds. REL : the values programmed in ALR and AHR are alarm differentials referred to SP and SP+HYS.
		 Temperature alarm with relative thresholds (ATM=REL).
ALA	-50... 110°C	Low temperature alarm threshold.
AHA	-50... 110°C	High temperature alarm threshold.
ALR	-12.0...0.0°C	Low temperature alarm differential. With ALR=0 the low temperature alarm is excluded.
AHR	0.0... 12.0°C	High temperature alarm differential. With AHR=0 the high temperature alarm is excluded.
ATI	T1; T2; T3	Probe used for temperature alarm detection.
ATD	0... 120min	Delay before alarm temperature warning.
ADO	0... 30min	Delay before door open alarm warning.
AHM	NON; ALR; STP;	Operation in case of high condenser alarm NON : high condenser alarm inhibited (<i>the following parameter will be</i> ACC). ALR : in case of alarm, "HC" flashes in the display and the buzzer is switched on. STP : in addition to the alarm symbols displayed, the compressor is stopped and defrosts are suspended.
AHT	-50...110°C	Condensation temperature alarm (referred to T3 probe).
ACC	0...52 weeks	Condenser periodic cleaning. When the compressor operation time, expressed in weeks, matches the ACC value programmed, "CL" flashes in the display. With ACC=0 the condenser cleaning warning is disabled and CND disappears from Info Menu.
IISM	NON; MAN; DI2	Switchover mode to second parameter set NON : inhibition to use the second parameter group (<i>the following parameter will be</i> SB). MAN : button M switches the two parameter groups over. DI2 : switchover to the second parameter group when the auxiliary DI2 input makes.
IISL	-50... IISH	Minimum limit for IISP setting.
IISH	IISL... 110°C	Maximum limit for IISP setting.
IISP	IISL... IISH	Setpoint in mode 2.
IIHY	1.0... 10.0°C	OFF/ON differential in mode 2.
IIFC	NON;TMP; TIM	Fan control in mode 2. See FCM.
IIDF	0...99 hours	Built-in timer value for an automatic defrost to take place, in mode 2.
SB	NO/YES	Stand-by button ⊗ enabling.

DI1	NON; DOR; ALR; RDS.	DI1 digital input operation NON : digital input 1 not active. DOR : door input. ALR : when contact opens an alarm is generated (if AHM=STP, the compressor is stopped and defrosts are suspended). RDS : when contact makes a defrost is started (remote control).
DI2	NON; DOR; ALR; RDS; IISM; T3; SET	DI2 digital input operation NON : digital input 2 not active. DOR : door input. ALR : when contact opens an alarm is generated (if AHM=STP, the compressor is stopped and defrosts are suspended). RDS : when contact makes a defrost is started (remote control). IISM : when contact makes the second parameter group is active. T3 : probe T3 input. SET : potentiometer setpoint input.
T3M	DSP; CND.	Auxiliary probe T3 operation DSP : temperature T3 to be displayed. CND : condenser temperature measurement.
OS3	-12.5..12.5°C	Probe 3 offset.
LSM	NON; MAN; D1O; D2O; D2C.	Light control mode NON : light output not controlled. MAN : light ouput controlled through button M D1O : when DI1 is open, light output is on. D2O : when DI2 is open, light output is on. D2C : when DI2 is closed, light output is on.
OA1	NON; FAN; DEF; LGT; 0-1; ALO; ALC	AUX 1 output operation NON : output disabled (always off). FAN : output enabled for fan control. DEF : output enabled for defrost control. LGT : output enabled for light control. 0-1 : the relay contacts follow the on/standby state of controller. ALO : contacts open when an alarm condition occurs. ALC : contacts make when an alarm condition occurs.
OA2	See OA1	AUX2 output operation. See OA1.
OS1	-12.5..12.5°C	Probe T1 offset.
T2	NO/YES	Probe T2 enabling (evaporator).
OS2	-12.5..12.5°C	Probe T2 offset.
TLD	1...30 min	Delay for minimum temperature (TLO) and maximum temperature (THI) logging.
SCL	1°C; 2°C; °F	Readout scale. 1°C : measuring range -50...110°C (0.1°C resolution within -9.9 + 19.9°C interval, 1°C outside) 2°C : measuring range -50...110°C °F : measuring range -58...180°F
SIM	0...100	Display slowdown.
ADR	1...255	BIT25 address for PC communication.

WIRING DIAGRAMS

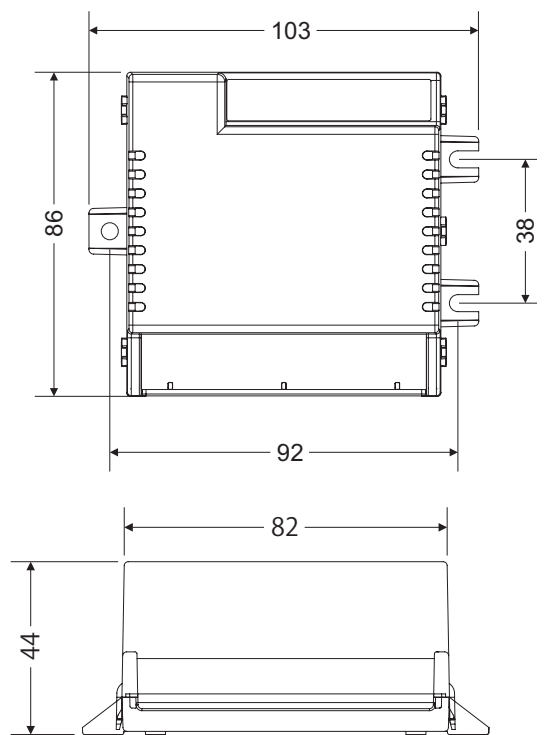
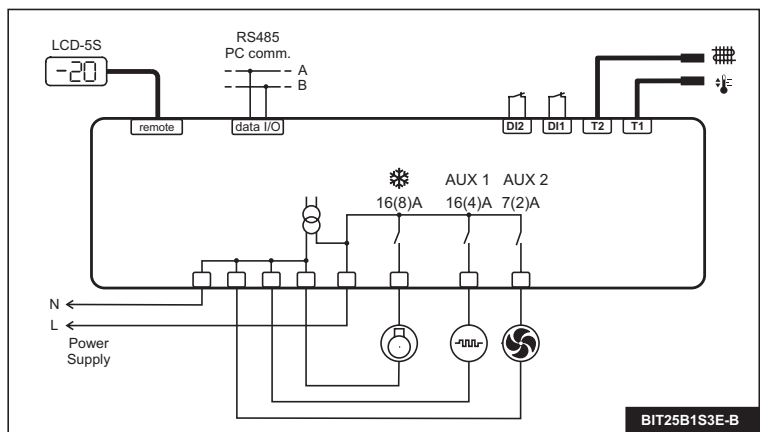

TECHNICAL DATA

Power supply
BIT25...E 230Vac±10%, 50/60Hz, 3W
BIT25...U 115Vac±10%, 50/60Hz, 3W
BIT25...W 115...230Vac±10%, 50/60Hz, 3W

Relay output max loads
Compressor 16(8)A 240Vac
Auxiliary loads 1 16(4)A 240Vac
Auxiliary loads 2 7(2)A 240Vac

Input
NTC 10KΩ@25°C LAE Part No. SN4...

Measurement Range

-50 / -9.9 ... 19.9 / 110°C
-50...110°C, -58...180°F

Measurement accuracy

<0.5°C within the measurement range

Operating conditions

-10 ... +50°C; 15%...80% r.H.

CE - UL (Approvals and Reference norms)

EN60730-1; EN60730-2-9; EN55022 (Class B); EN50082-1

lae
ELECTRONIC

VIA PADOVA, 25
31046 ODERZO (TV) /ITALY
TEL. +39 - 0422 815320
FAX +39 - 0422 814073
www.lae-electronic.com
E-mail: sales@lae-electronic.com