

Industrial Air Heater Product Guide



Contents

Pages 3-13

History, Applications, Air Sources, Heater Selection, Calculations
Control, Connections, Controllers

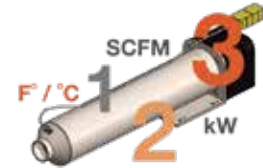

Pages 14-15

Series I, II, III - Basic Quartz Insulated Heaters



Pages 16-18

Hot Air Tools - Compact Steel Insulated Heaters with Built-in
Type K Thermocouple



Pages 19-22

Serpentine II, VI - Triple Pass Exchanger Housings



Pages 23-28

Threaded Inline - High Heat, High Pressure Heaters



Pages 29-34

Jet, Max - Precise Control, Over-temp Protection with
2 Built-in Type K Thermocouples



Pages 35-37

Max HT - Precise Control, Over-temp Protection for High
Heat Applications with 2 Built-in Type K Thermocouples



Pages 38-39

Troubleshooting, Glossary, Reference Data



Pages 40-42

Warranty, Contact Information, Global Map



Process Heat Products



Serpentine™

Tutco SureHeat understands industrial facilities are dependent upon productivity, safety, and efficiency. Every component, machine, and process impacts operational cost. In today's industrial environments, meeting productivity goals can mean the difference between success and failure. As the need for higher temperatures has increased so has productivity demands. This is a problem for most air heaters. Reaching and maintaining temperatures quickly can result in dramatically reduced heater component life. The Tutco SureHeat process heat engineering team developed the innovative Serpentine™ heating element to exceed the demands and overcome the challenge. Its manufacturing processes ensure better heat transfer, faster, and higher temperatures and a longer heating element life unmatched in the marketplace.

Tutco SureHeat electric air heaters are proudly engineered and manufactured in the USA. With over 200 variations of catalog products available, Tutco SureHeat products are used in aerospace, automotive, industrial, electronic, food, medical, packaging, plastic, pharmaceutical, printing, and numerous other applications throughout the world.

Applications

Tutco SureHeat has developed hundreds of specialty products for the most demanding applications. With air temperatures quickly and accurately controllable to 1652°F (900°C), our air heaters are perfect solutions for critical industrial hot-air processes.



Aerospace

- Combustion
- Valve / Flow Simulation
- Component Testing
- Maintenance Repair & Overhaul



Automotive

- Bonding Body Panels
- Curing Adhesives
- Vacuum Forming
- Testing and Simulation



Electronics

- Wave Soldering Air Knife
- Soldering / De-soldering
- PCB Drying Processes



Packaging

- Sealing / Curing
- Heat-shrinking
- Forming



Medical

- Pharmaceutical Manufacturing
- Packaging Processes
- Medical Hardware Sterilization



Plastics

- Salt Removal From Rubber Extrusions
- Bending / Forming of Parts
- Bonding Molded Parts



Textiles

- Welding plastic or vinyl fabrics
- Heat-treating specialty fabrics



Paper Printing

- Speed drying coated paper
- Adhesive activation and curing
- Ink drying

Air Sources



To ensure longer heater life and safe operation, it is recommended that all guidelines are followed. Please read and understand the heater operating manual before use. Failure to follow guidelines can result in heater damage, failure or personal injury.

Only use air or inert gases with electric air heaters. Never use volatile or combustible gases. Compressed air or regenerative blowers are required to supply air flow and prevent failure of the heater element. The air source should be clean and dry. Dirt, grease, oil, oil vapors and corrosive or reactive gases will damage the heater.

Regenerative Blowers

Regenerative blowers are compact and inexpensive clean air sources. They can provide large amounts of low-pressure air for heating applications. Blower size is based on the maximum amount of airflow (CFM or LPM) it can produce without any inlet or exit restrictions. When a heater or other restriction is attached to a blower, the flow decreases. If the blower is severely restricted, the blower motor can overheat and fail. When designing your heating system, try to minimize air restrictions and select a blower sufficient to overcome the back-pressure generated by the heater, flare nozzle and associated piping. Smaller diameter heaters such as the Series I, II, III, Hot Air Tool, Serpentine II, and smaller diameter threaded inlines should not be used with regenerative blowers.

Compressed Air

Compressed air is commonly available in most factories. It is high-pressure regulated air (typically to 100 psi), and often contains oil for lubricating pneumatic valves and equipment. Oil must be filtered to prevent fouling and damage to the electric air heater elements. When measuring compressed airflow rates, be sure you are measuring Standard CFM or Standard LPM units. “Standard” means that the units are at standard temperature and pressure. Many flow meters are labeled SCFM, but this is actually incorrect at the high pressures produced by air compressors. For accurate flow measurements, consult your flow meter manual for converting CFM to “Standard” CFM. In the diagram below, the flow meter reading is converted to SCFM using Dwyer ball-type flow meter conversion instructions.

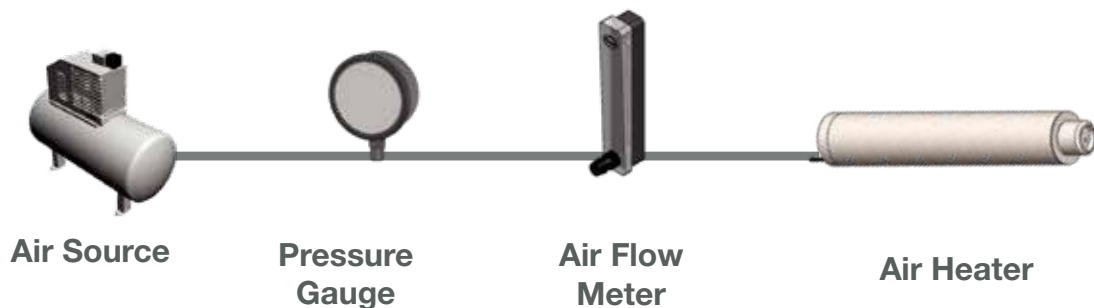

Steps to Selecting an Air Heater

An electric air heater works by transferring electrical energy into a passing air stream. The power and amount of air flow needed determine how hot the air heater will get.

Step 1:

Determine Standard Flow-rate (SCFM)

$$\text{SCFM} = \text{CFM} \times \sqrt{(P + 14.7) / 14.7}$$

Step 2:

Calculate Power Requirement (kW)

$$\text{kW} = \text{SCFM} \times (\text{Exit Temp} - \text{Inlet Temp}) / 2500$$

or

$$\text{kW} = \text{SCFM} \times (\text{Exit Temp} - \text{Inlet Temp}) / 3000 \times 1.2$$

Step 3:

Check Performance Curve

Step 4:

Determine Heater Pressure Rating

Step 5:

Other Considerations

- Supply Voltage
- Physical Size
- Mechanical Connections

ACFM = Flow Rate (Cubic Feet / Minute) at Actual Conditions

P = Pressure

T= Exit Temp = Desired Temperature (°F)

kW = Power

SCFM = Flow Rate (Cubic Feet / Minute) at Standard Temperature and Pressure

Inlet Temp = Inlet Temperature (typically 70°F)

2500 = Unit Conversion Factor (20% Heat Loss)

Tutco SureHeat offers an air heater calculator and product recommendation tool online. This simple tool calculates and converts commonly used data to help determine the correct air heater products based on calculated results. Check it out on our website at www.tutcosureheat.com.

Air Heater Calculation Examples

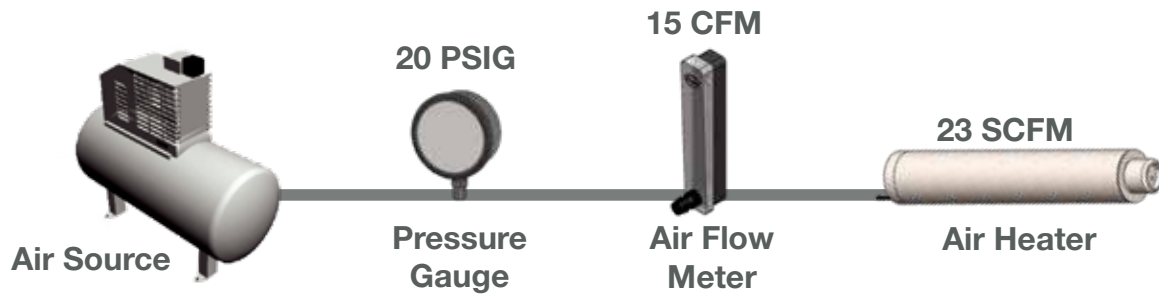

Use the above information to calculate SCFM.

$$\begin{aligned} \text{SCFM} &= 15 \times \sqrt{(20 + 14.7) / 14.7} \\ \text{SCFM} &= 15 \times \sqrt{2.36} \\ \text{SCFM} &= 15 \times 1.54 = \underline{23} \end{aligned}$$

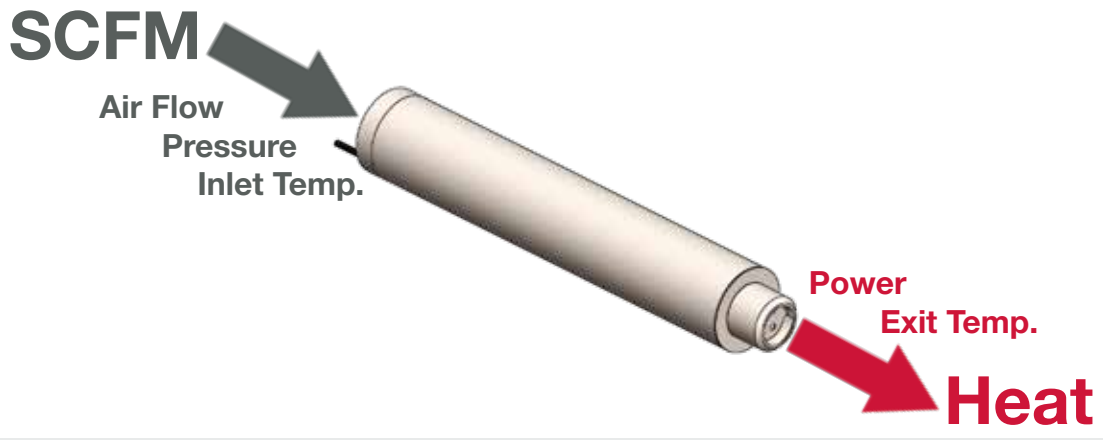

To calculate power requirements; use the above example and desired exit temperature of 800°F.

$$\text{kW} = 23 \times (800^\circ\text{F} - 70^\circ\text{F}) / 2500 = \underline{6.72\text{kW}}$$

Recommended Heater Controls



Heater control systems are critical for proper heater set-up and longer element life. Before turning the power on to any heater, it is essential to have the proper air flow through the heater. Only qualified professionals should install electric air heaters and controllers. Follow all applicable electrical codes and recommended wiring.

Open-Loop (Manual) Control

This simple method of control uses a manually operated power controller to apply a fixed voltage to the heating element. Using this system, the operator manually adjusts the controller to change heater temperature. If the airflow is suddenly interrupted, the element could fail. This is a common and inexpensive controller and often used with simple single phase standard catalog products.

Closed-Loop (Feedback) Control

Closed-loop heater control systems use a power controller, temperature controller and thermocouple to monitor and provide a constant output temperature, regardless of changes in airflow. The typical temperature controller provides a convenient display of the **air temperature**. (not the element temperature)

Power Controller

SCR (Silicon Controlled Rectifier) power controls will provide the smoothest power regulation for electric air heaters. Please contact Tutco SureHeat before using other power controllers, such as SSR (Solid State Relays) or other fast-switching controllers.

Temperature Controller

Use only digital temperature controls with Type K thermocouple inputs. The temperature control output must match the input of the power control (i.e., 4-20mA or 0-10VDC). A standard PID-type control with a wide proportional band setting will work best to minimize temperature overshoot. PID parameters may be auto-tuned, but only at temperature specifications below the maximum of the heater. Monitor the heater temperature rise and turn power off immediately if it rises above the heater specification during the auto-tune cycle.



Thermocouple

Use only a fine wire (0.030" max. wire diameter), exposed junction, Type K thermocouple placed within 1" of the heater exit for accurate temperature readings. Other thermocouple styles, or varying the distance from the heater exit, will result in temperature measurement errors and thus the potential for heater failure.

Heater Control Connection Examples:

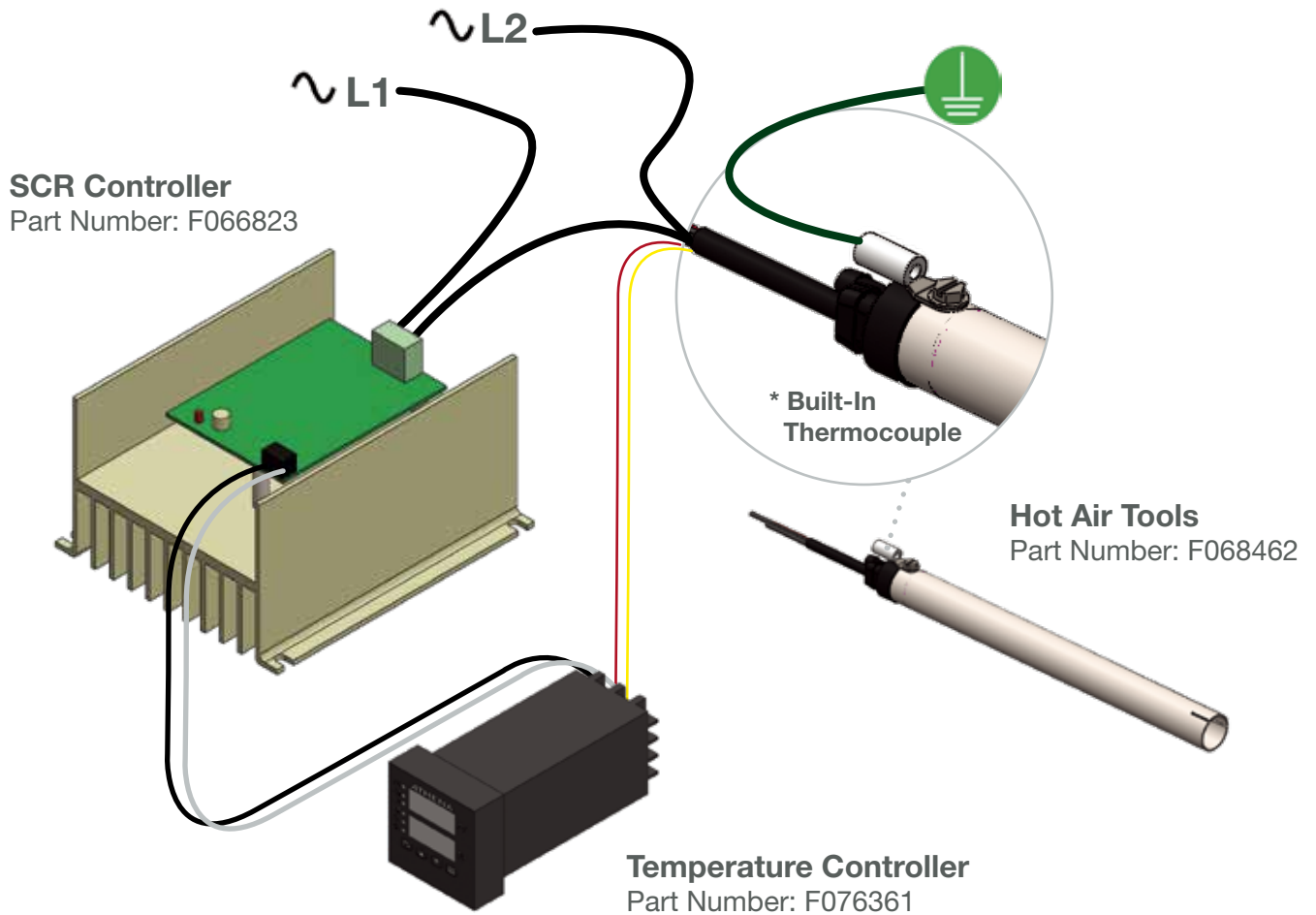

Thermocouple Placement

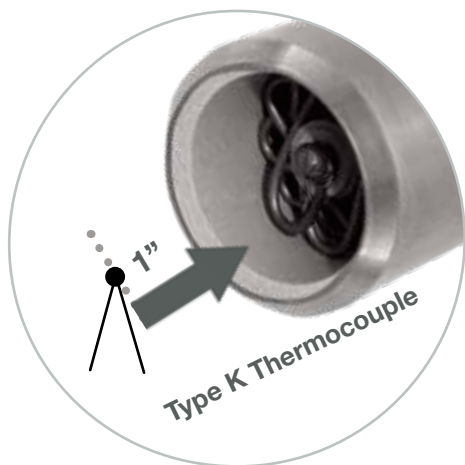







TC placement is very important. The exposed TC junction should be no further than 1" from the Serpentine element (Left).

Take precaution to have the exposed element slightly above the center of the ceramic tube (Right).



Heater Controls

Product Picture	Part Number	Description
	F057081	<ul style="list-style-type: none"> - Single phase voltage regulator - 0-10 scale potentiometer - Open-loop (manual) power control - Input: 120-277VAC, 50/60Hz, 25A - Output: 17-99% of input voltage - UL recognized
	F066823	<ul style="list-style-type: none"> - Phase-angled SCR power controller - Regulate air heaters up to 6000W - Inputs: 120/240VAC, 50/60Hz, 30A, and 4-20mADC - Large Aluminum heat-sink for cooling - For use with digital temperature controller F076361
	F072808	<ul style="list-style-type: none"> - 2 zone temp switch for SSR or SCR power controllers - Reduces DC signal between temp controller and power controller - Adjustable set points 300°F (149°C) and 1405°F (763°C) - Input: 120VAC, 50 / 60Hz, 1Ø - UL recognized, CE
	F076361	<ul style="list-style-type: none"> - 1/16 DIN sized temperature controller - NEMA 4X front panel (IP65) - Type K Thermocouple input - Input: 120/240VAC, 50/60Hz, 1Ø - Output: 0-20mA for use with SCR power controllers - Relay alarm for heater element safety - UL recognized, CSA, CE
	F074835	<ul style="list-style-type: none"> - Analog safety switch for SureHeat® Jet and Max heaters - Switch interrupts main temp control - Adjustable set point 300-1405°F - Input: 120-240VAC, 50/60Hz - UL recognized, CSA, CE
	F075526	<ul style="list-style-type: none"> - Use with F074718 / F074719 / F074723 / F074727 - NEMA 4X enclosure - Input: 240V, 50/60Hz, 40A - Includes: Digital temperature controller, Inlet limit controller, SSR power controller, Circuit breaker, Power-ON indicator - RS-232 Serial Communication - UL recognized, CE

Product Picture

Part Numbers**Description**

Control Panels

F078135

- **240VAC or 480VAC / 30A / 3 ϕ / 50-60Hz**
- **Max Heaters:** F074723 / F074724 / F074726 / F074728 / F074731 / F074734
- **Max HT Heaters:** F077083
- **Thread Inline Heaters:** F038823 / F038824 / F038825 / F038826 / F076418
- NEMA 12 painted steel enclosure
- 24"H x 24"W x 10"D (610x610x254)
- UL508 approved panel, CE on request



F078216

- **380/400V / 30A / 3 ϕ / 50-60Hz**
- **Max Heaters:** F074725 / F074729
- **Max HT Heaters:** F077082
- NEMA 12 painted steel enclosure
- 24"H x 24"W x 10"D (610 x 610 x 254)
- UL508 approved, E-Stop, CE



F078136

- **240VAC or 480VAC / 60A / 3 ϕ / 50-60Hz**
- **Max Heaters:** F074727 / F074732 / F074736
- **Max HT Heaters:** F077081 / F077085
- **Threaded Inline Heaters:** F077028 / F077065 / F063007 (1 ϕ only)
- NEMA 12 painted steel enclosure
- 24"H x 24"W x 10"D (610 x 610 x 254)
- UL508 approved panel, CE on request







F078217

- **380/400V / 60A / 3 ϕ / 50-60Hz**
- **Max Heaters:** F074735 / F074733
- **Max HT:** F077084
- NEMA 12 painted steel enclosure
- 24"H x 24"W x 10"D (610 x 610 x 254)
- UL508 approved, E-Stop, CE

All Max & Max HT Control Panel have the following components

- Solid state power controller SSR type
- 1/16 Din PID temp controller
- ON/OFF switch
- Power ON LED
- Reset button
- 3-Pole circuit breaker with door mounted operating handle
- LAN connectivity
- High limit temp controller for low airflow
- Custom options are available per request

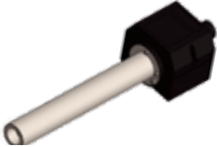
Air Heater Products

Product	Description	Power (kW)
Series I,II,III 	<ul style="list-style-type: none"> - Inexpensive Spot-Heating Applications - Quartz Insulator Tube - Open or Nozzle End - Single phase 	0.6 - 2.4
Hot Air Tools 	<ul style="list-style-type: none"> - Compact Size - Built-in Type K Thermocouple - Precise Temp Control +/- 1°F - Single phase 	1.5 - 3.5
Serpentine II, VI 	<ul style="list-style-type: none"> - Triple Pass Exchanger - Improved Safety & Efficiency - Easy to Service & Replace Element - Single phase 	2.0 - 8.0
Threaded Inline 	<ul style="list-style-type: none"> - High-Pressure Applications - Optional Power Connections - Critical High-Heat Processes - Single or 3 phase 	1.6 - 24.0
Jet 	<ul style="list-style-type: none"> - All-Purpose Single Phase Heater - (2) Built-in Type K Thermocouples - Built-in Over-temp Protection - Single phase 	3.0 - 8.0
Max 	<ul style="list-style-type: none"> - All-Purpose Three Phase Heater - (2) Built-in Type K Thermocouples - Built-in Over-temp Protection - Single or 3 phase 	6.0 - 36.0
Max HT 	<ul style="list-style-type: none"> - High Temperature Applications - (2) Built-in Type K Thermocouples - Built-in Over-temp Protection - 3 phase 	18 - 36.0

Max. Air Temperature °F (°C)	Max. Air Pressure psi (bar)	Use with Blower?
1600 (871)	7 (0.5)	No
1400 (760)	60 (4.0)	No
1500 (815)	25 (1.7)	No
1400 (760)	150 (10.0)	No
1400 (760)	60 (4.0)	Yes
1400 (760)	60 (4.0)	Yes
1652 (900)	60 (4.0)	Yes

Series I, II, III Air Heaters

General Description

Series heaters are general purpose compact electric air heaters using Serpentine™ wire heating elements within a Quartz open-end (Style A) or nozzle (Style B) for spot-heating applications. The Series products are typically powered by open-loop (manual) power controllers. The air inlet is a high-temperature silicone rubber adapter with male spade power connectors and a ground. Mounting in existing or new equipment is made easy by the included bracket.

Open-Loop Connection Diagram

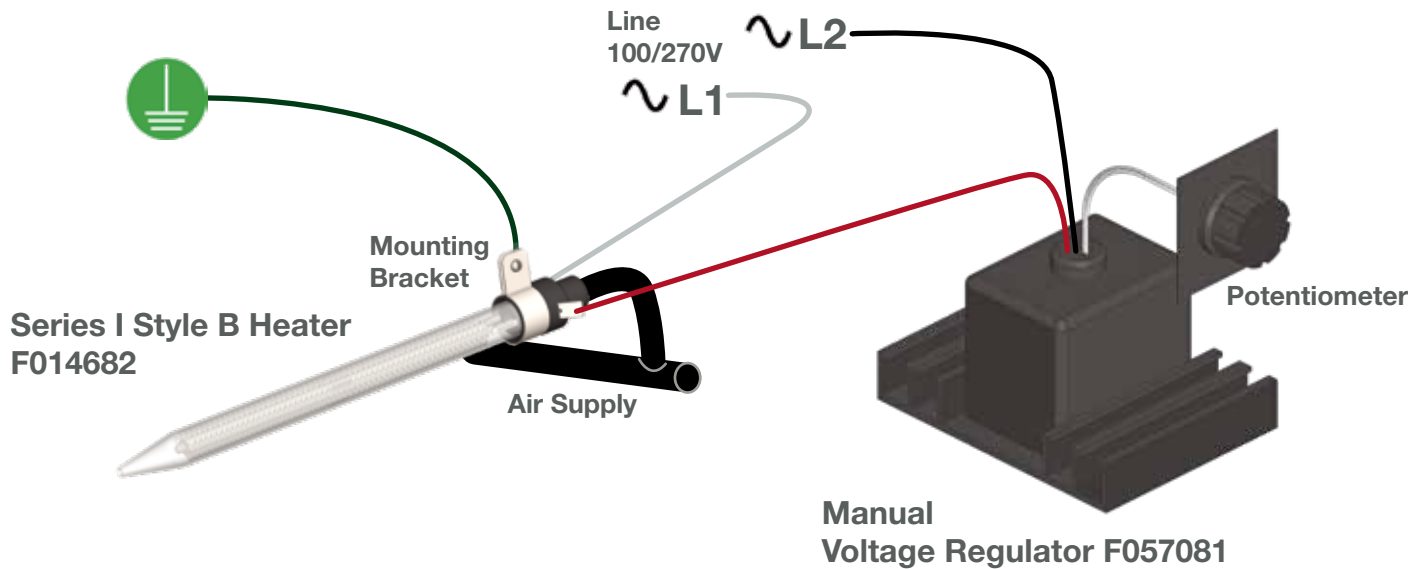

Minimizing Series Element Failures

- Always ensure air is flowing before powering the heating element
- Slowly regulate the ramp up time using the potentiometer to control AC voltage

Series I	Series II	Series III
<ul style="list-style-type: none"> – Small diameter – Long Quartz tube – Max. 1400°F – Up to 300 SCFH @ 1000°F 	<ul style="list-style-type: none"> – Same diameter as Series I – Smaller Quartz tube length – Nominal line voltages – 60V at Max. 1200°F – 300 SCFH @ 1000°F 	<ul style="list-style-type: none"> – Larger diameter – Temperatures to 1600°F – Delivers up to 600 SCFH @ 825°F

Stainless Steel Outer Shields – Style A Open-Ended

F015509	Series I P/N F014372
	Series I P/N F010226
	Series II P/N F016501, F016503

Dimensions / Installation Reference

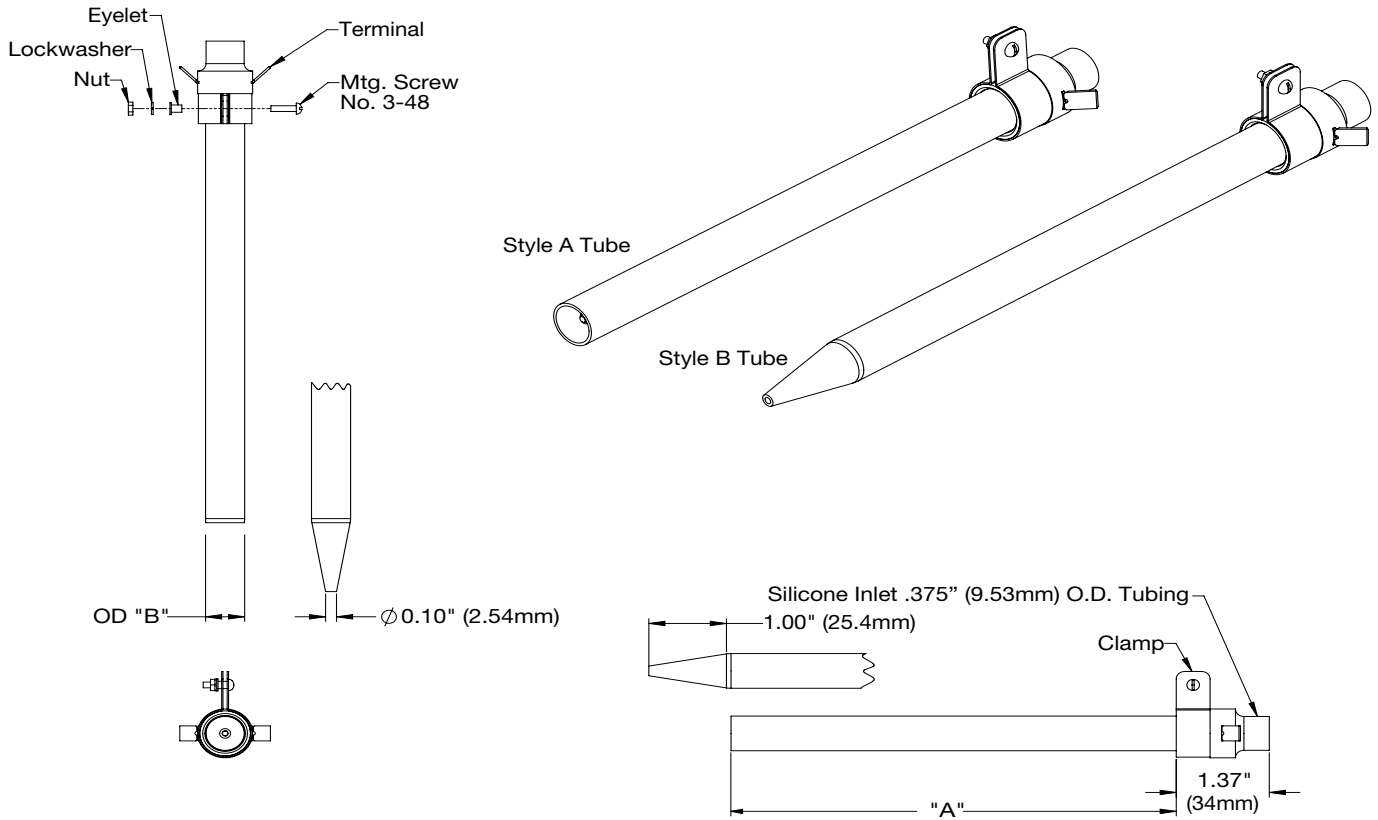

Part Number	Style	Max. Watt	Max. Volts	Max. Amps	Length "A"	Diameter "B"
-------------	-------	-----------	------------	-----------	------------	--------------

Series I

F010226	A	1050W	180V	5.83A	6.88" (175mm)	.41" (10mm)
F014372	A	1000W	130V	7.69A	7.75" (197mm)	.41" (10mm)
F014682	B	680W	145V	4.69A	7.88" (200mm)	.41" (10mm)
F014683	B	650W	105V	6.19A	8.75" (222mm)	.41" (10mm)

Series II

F016501	A	1125W	130V	8.65A	3.88" (98mm)	.41" (10mm)
F016503	A	850W	80V	10.62A	3.88" (98mm)	.41" (10mm)
F016502	B	600W	95V	6.32A	4.88" (124mm)	.41" (10mm)
F016504	B	650W	70V	9.29A	4.88" (124mm)	.41" (10mm)

Series III

F017558	A	2050W	160V	12.81A	6.88" (175mm)	.59" (15mm)
F017575	B	1450W	135V	10.74A	7.88" (200mm)	.59" (15mm)



Hot Air Tools

General Description

Hot Air Tools are multi-purpose electric heaters with a built-in thermocouple for precise temperature control. The compact size makes this product perfect for single phase OEM applications. Its 304 stainless steel body construction is slotted for flared accessories and is made to withstand pressures up to 60 psi (4 bar) and temperatures up to 1400°F (760°C)

Closed-Loop Connection Diagram

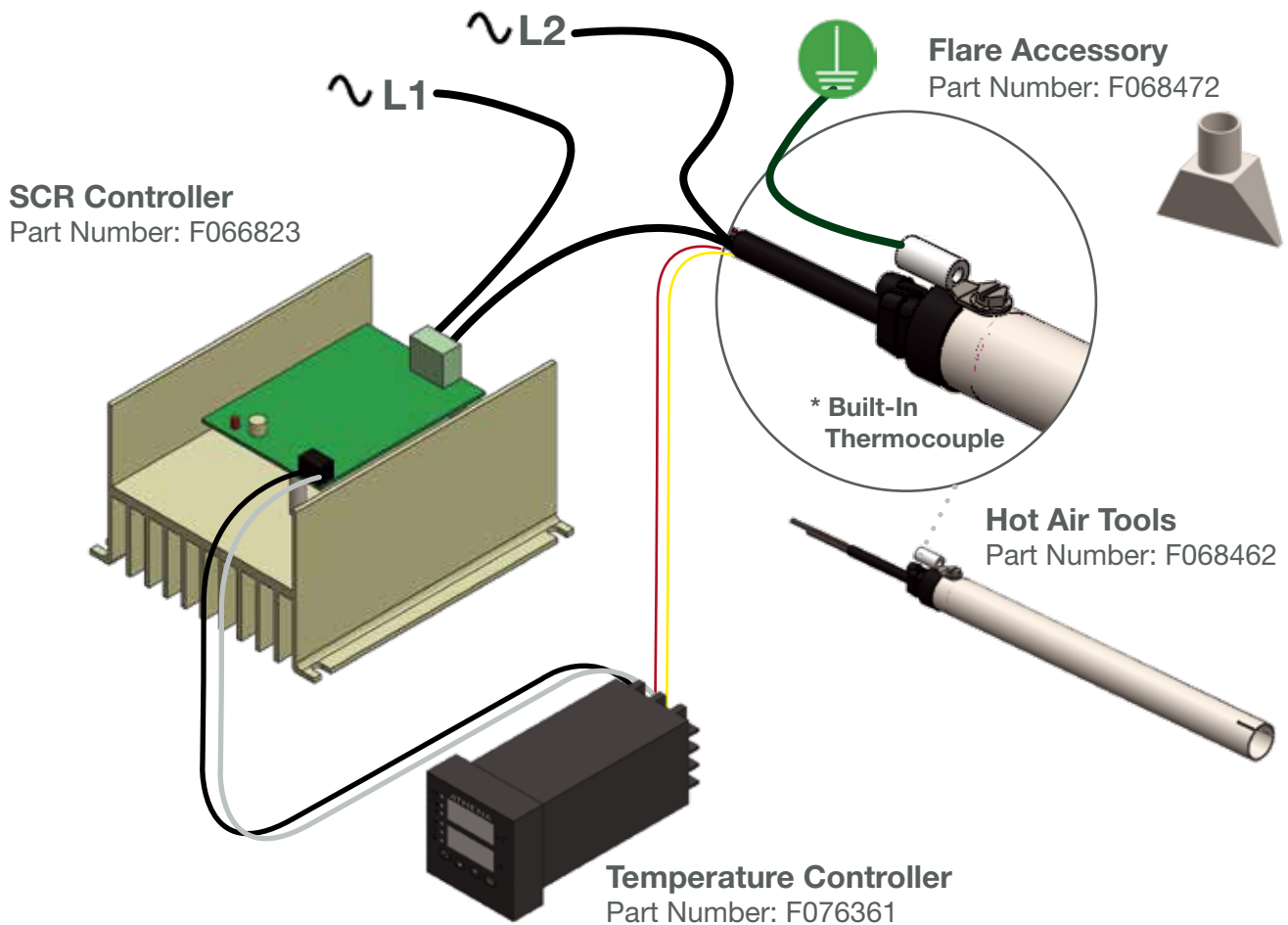

Minimizing Hot Air Tools Element Failures



1. Always ensure air is flowing before powering the heating element
2. Slowly regulate the ramp up time using the potentiometer to control the AC voltage
3. Use a temperature controller with 100ms cycle time

Dimensions / Installation Reference

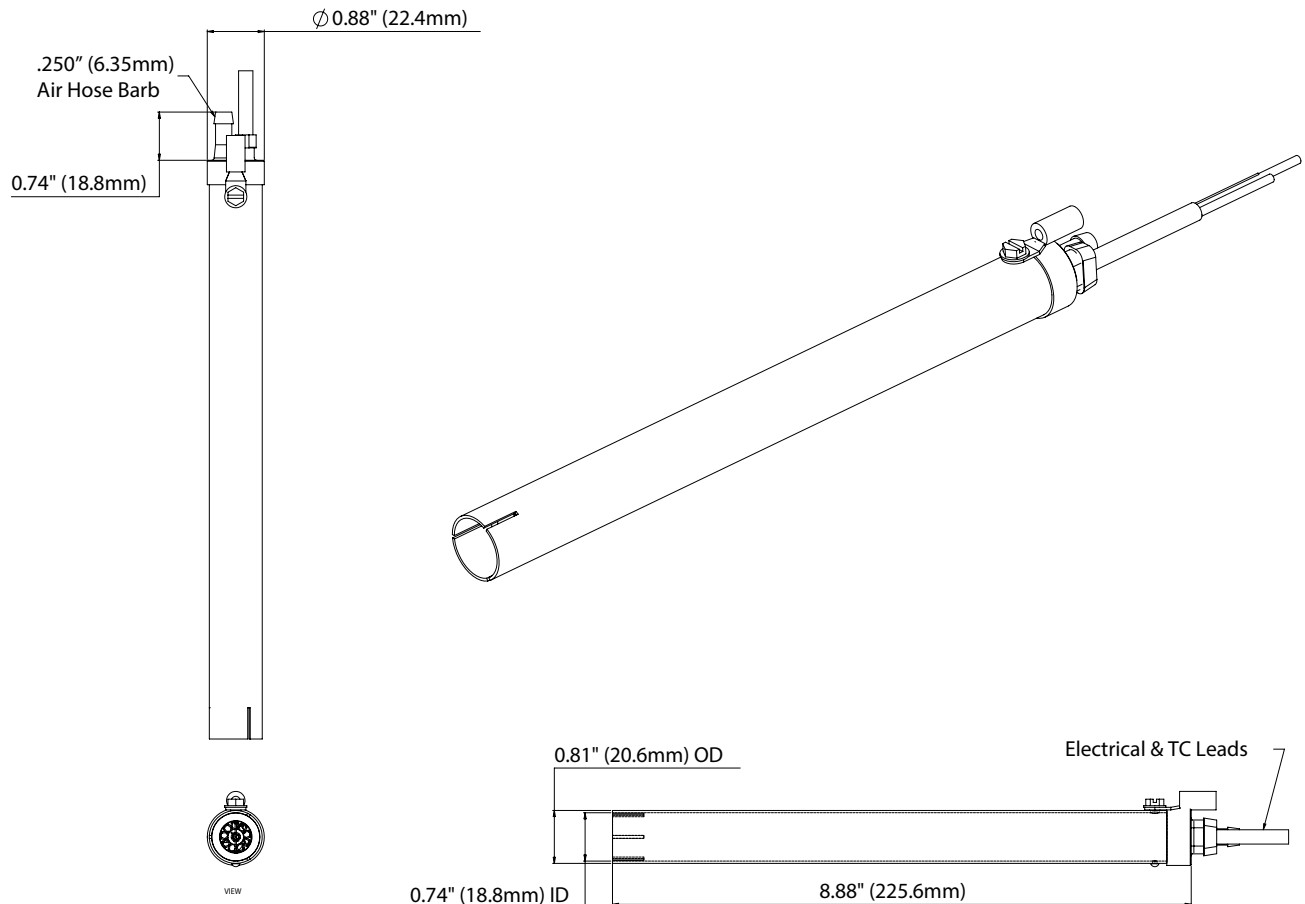

Hot Air Tools

Part Number	Max. Watt	Max. Volts	Max. Amps
F068462	1.5kW	120V	12.5A
F068463	2.0kW	240V	8.3A
F068464	3.5kW	240V	14.6A

Hot Air Tools Accessories

Part Number	Description
F068472	Flare Attachment Accessory
F066823	Closed-Loop SCR Power Controller
F076361	Digital Temperature Controller

Hot Air Tools Performance Curves

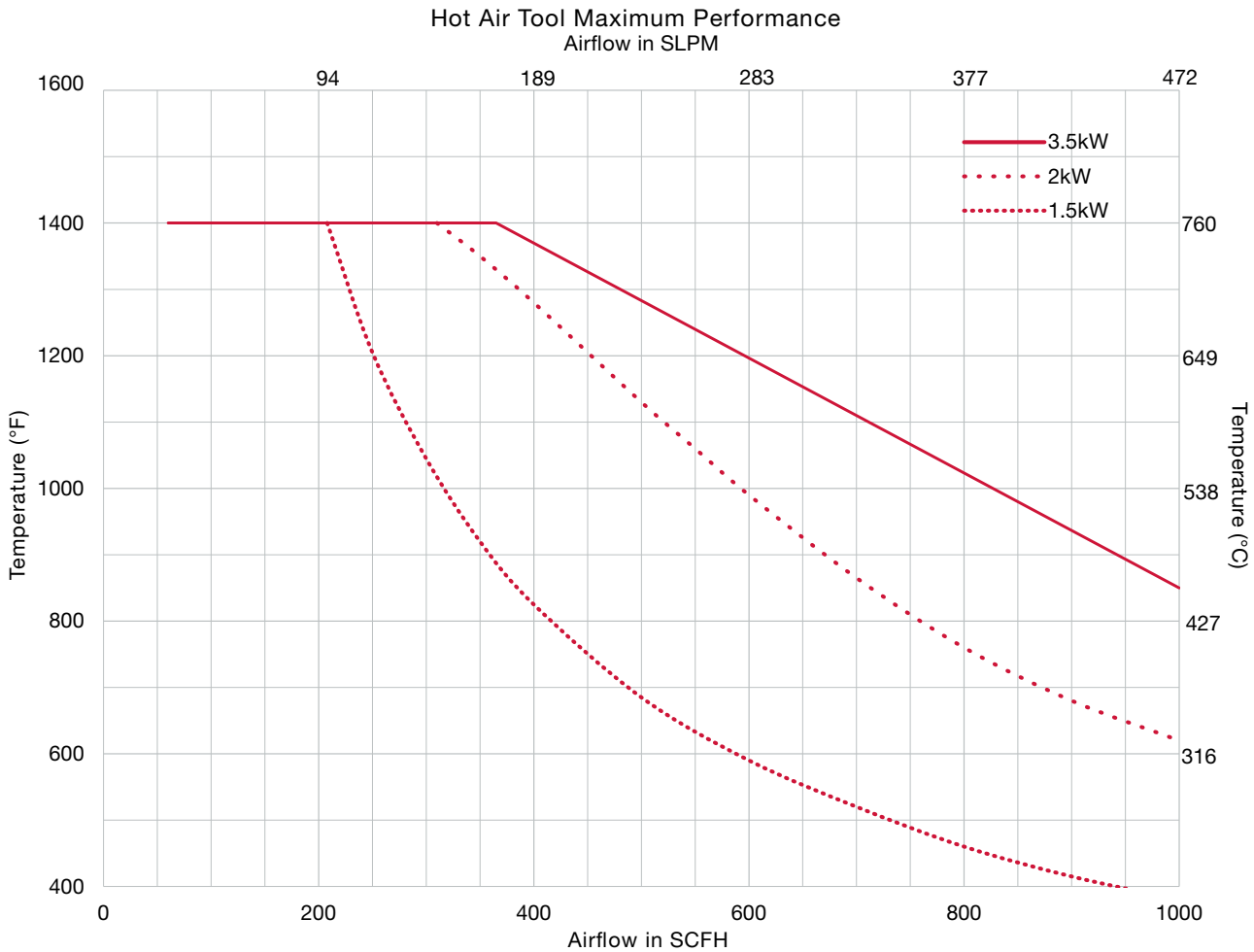

Notes:

- Temperatures are measured by internal 'K' T/C sensors. Use of other sensor types and / or locations can result in heater damage.
- Minimum airflow for accurate control is 60 SCFH
- Maximum air temperature is 1400°F (760°C) with supplied "K" T/C. Operating above this curve will void the product warranty.



Serpentine II, VI Triple Pass Air Heaters

General Description

The Serpentine Triple Pass heaters are modular field replaceable products. The heater unit consists of a Serpentine™ electric heater element that fits into a stainless steel “triple-pass” exchanger housing and makes electrical connections through fittings pressed into the base. The housing uses the incoming air to cool the outer shell prior to passing through the heater element. This minimizes radiant heat loss and provides a safe to the touch product to minimize injury to operators who come in contact with the heater.

Closed-Loop Connection Diagram

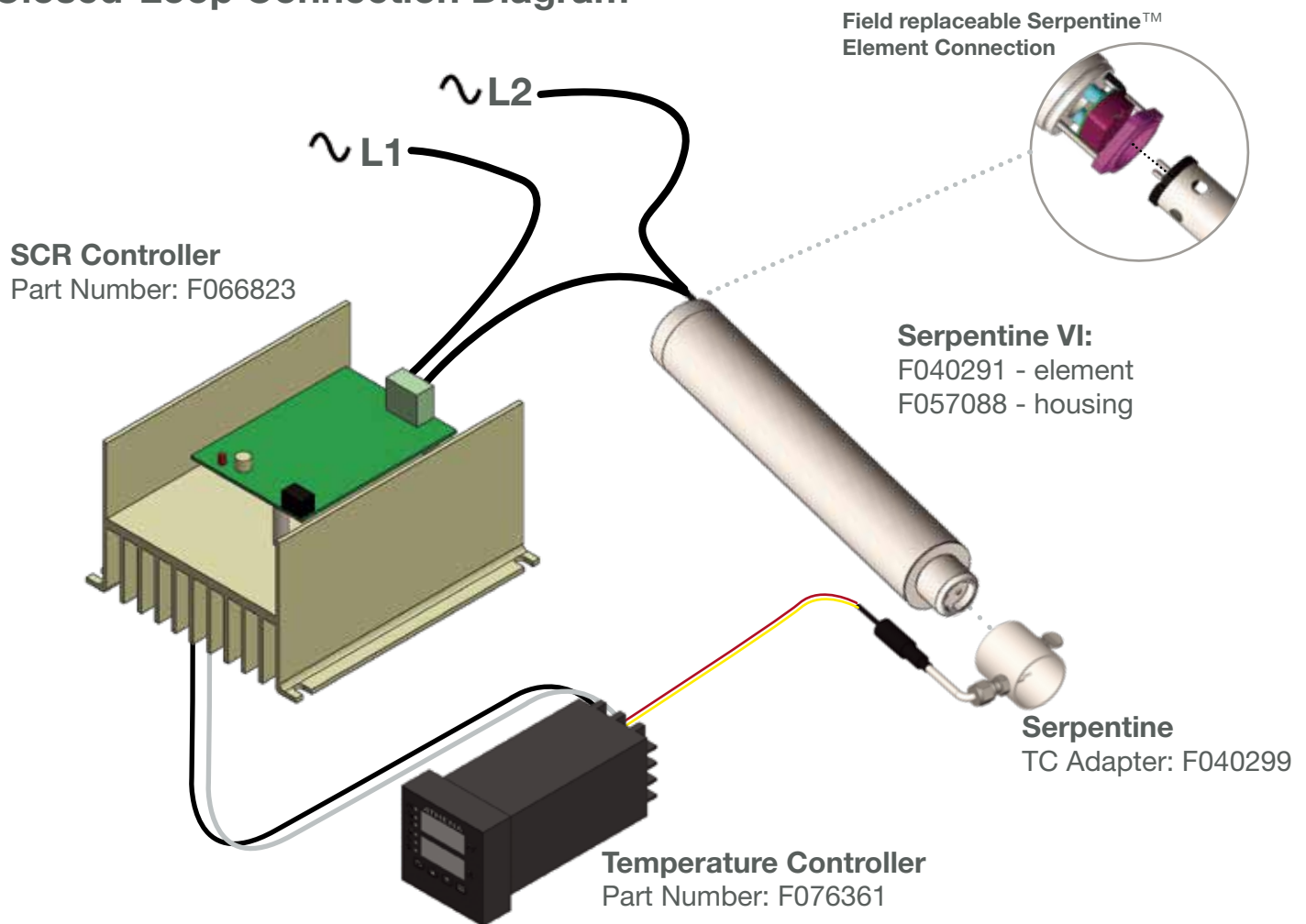

Serpentine II, VI Accessories

Part Number	Description
F039739	Serpentine II Base Adapter Assembly
F042339	Serpentine VI Base Adapter Assembly
F029485	Serpentine II TC Holder (includes TC)
F040299	Serpentine VI TC Holder (includes TC)
F039272	Type K thermocouple probe

Dimensions / Installation Reference

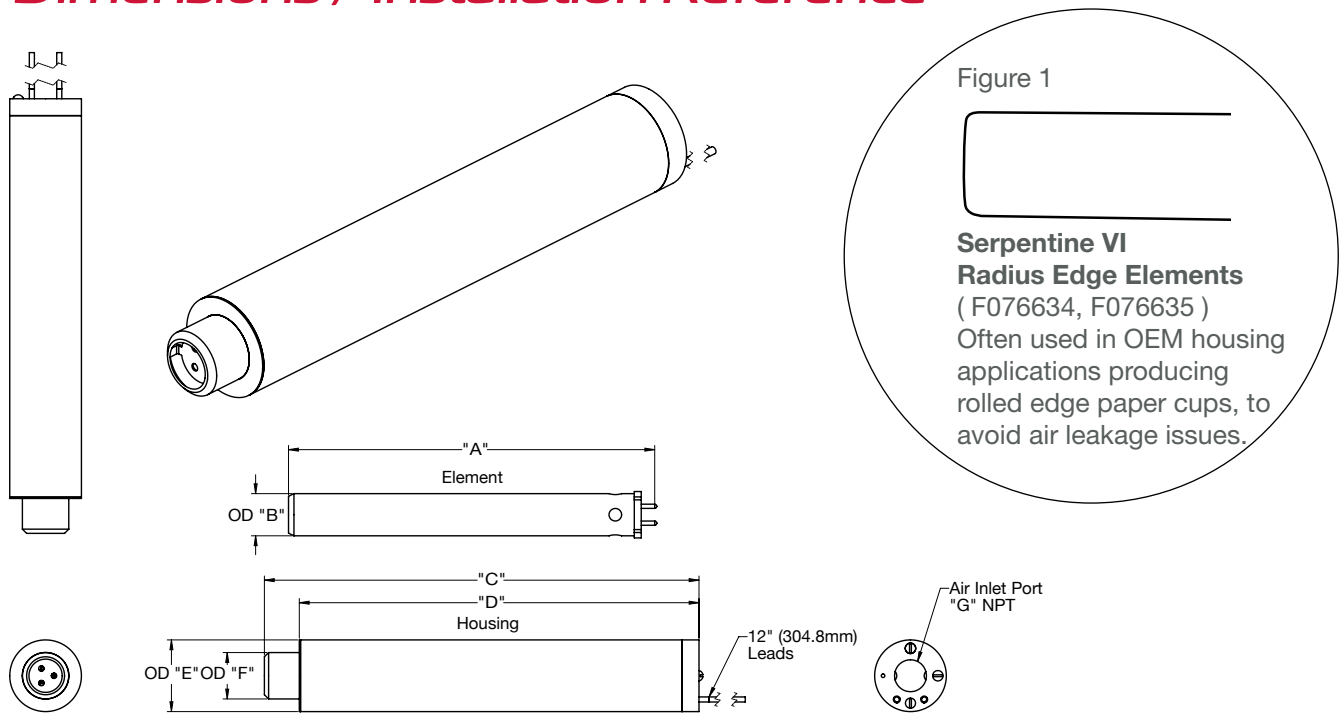

Serpentine Elements

Part Number	Max. Watts	Max. Volts	Max. Amps	Length "A"	Diameter "B"
Serpentine II Elements					
F029765	2.0kW	240V	8A	8.20" / 208mm	0.63" / 16mm
F029766	2.8kW	240V	12A	8.20" / 208mm	0.63" / 16mm
F029767	3.6kW	240V	15A	8.20" / 208mm	0.63" / 16mm
F060418	3.6kW(2-stage)	240V	15A	8.63" / 219mm	0.63" / 16mm

Serpentine VI Elements

F040291	5.0kW	240V	21A	10.88" / 276mm	1.25" / 32mm
F040292	6.0kW	240V	25A	10.88" / 276mm	1.25" / 32mm
F076634 (see fig.1)	6.0kW	240V	25A	10.88" / 276mm	1.25" / 32mm
F061429	6.0kW(2-stage)	240V	25A	10.88" / 276mm	1.25" / 32mm
F056548	8.0kW	240V	33A	10.88" / 276mm	1.25" / 32mm
F076635 (see fig.1)	8.0kW	240V	33A	10.88" / 276mm	1.25" / 32mm

Serpentine Housing Assemblies

Part Number	Dimensions				
	"C"	"D"	"E"	"F"	"G"
Serpentine II Housing F029763	10.0" / 254mm	9.0" / 229mm	1.6" / 40mm	0.7" / 18mm	3/8" NPT
Serpentine VI Housing F057088	12.9" / 327mm	11.9" / 302mm	2.1" / 54mm	1.4" / 35mm	3/4" NPT

Serpentine II Performance Curves

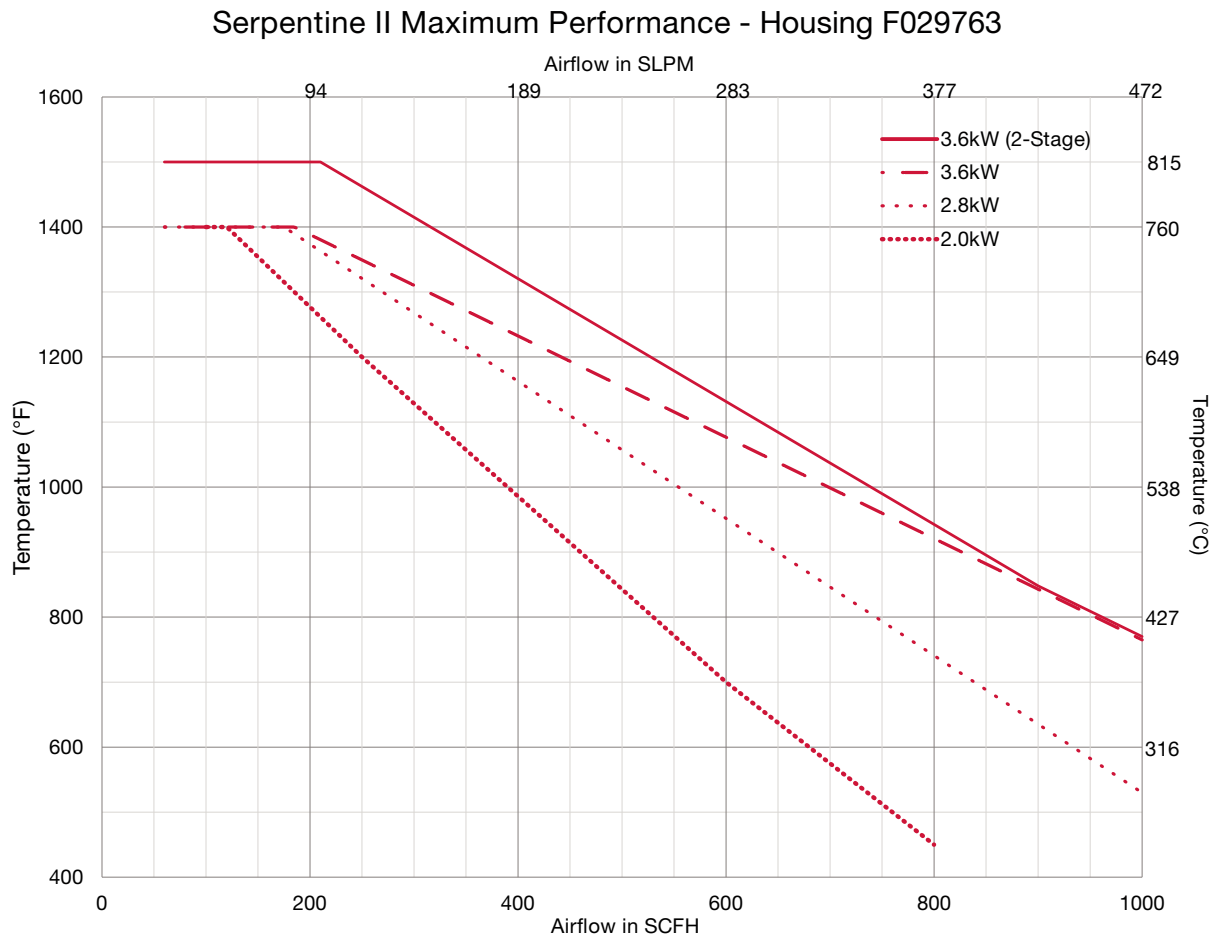

Notes:

- Temperatures are measured by internal 'K' T/C sensors.
- Use of other sensor types and locations can result in heater damage.
- Minimum airflow for accurate control is 60 SCFH
- Maximum air temperature is 1500°F (815°C)
- Operating above this curve will void the product warranty

Serpentine VI Performance Curves

Serpentine VI Maximum Performance - Housing F057088

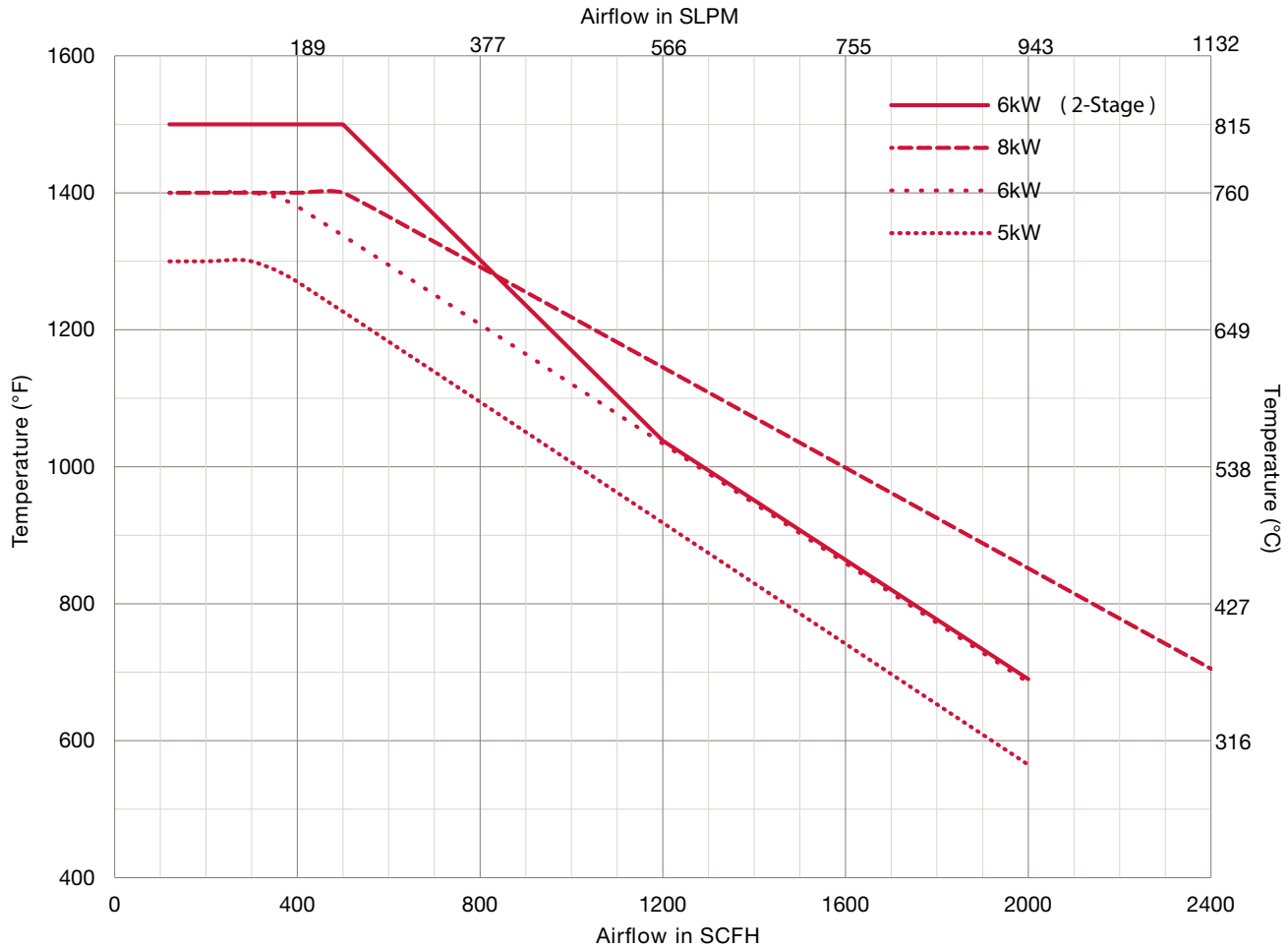

Notes:

- Temperatures are measured by 3/16" "K" T/C sensor Part #039272 mounted inside TC holder #040299
- TC Holder mounted on exit of #F057088
- Housing Assembly
- Use of other sensor types and mounting locations can result in heater damage
- Minimum airflow for accurate control is 60 SCFH
- Maximum air temperature is 1500°F (815°C)
- Operating above this curve voids the product warranty



Threaded In-line Heaters

General Description

Threaded in-line air heaters are UL Recognized products designed for industrial process heating applications requiring high-heat and high air pressure. Serpentine™ heating elements are installed into a 304 stainless steel housing and threaded at both ends. Tutco SureHeat threaded in-line heaters offer two styles, Style “A” and Style “B”. Style “A” should be used when an absolute leak-proof air system is required. Need a custom solution? We have supplied hundreds of customer specified variations. Contact us for more information.

Closed-Loop Connection Diagram

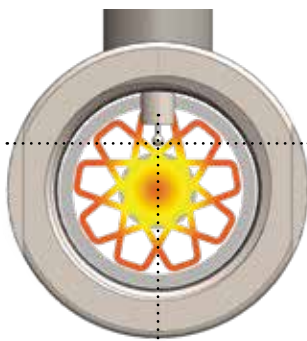
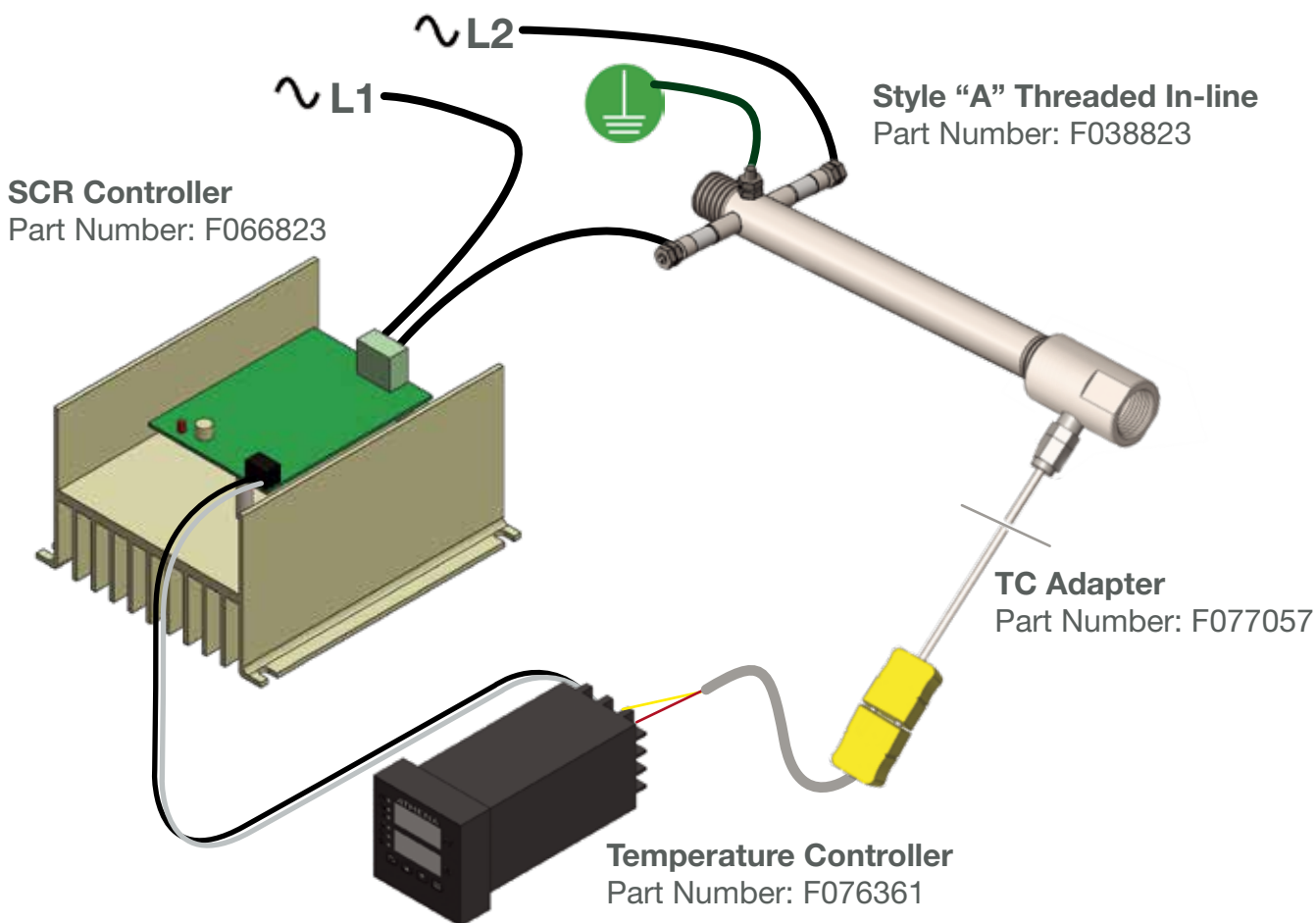

Make sure to properly mount the TC coupling so that the TC is slightly above the ceramic rod running through the center of the Serpentine™ heating element. The open end of the TC should be in the heated air stream as shown left.

Threaded In-line Thermocouple Adapters

THREADED INLINE TC ADAPTERS

MODELS NOT TO SCALE

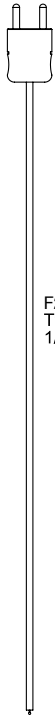

F206119
Type 'K' TC - Exposed Tip
1/8" OD x 12" Long

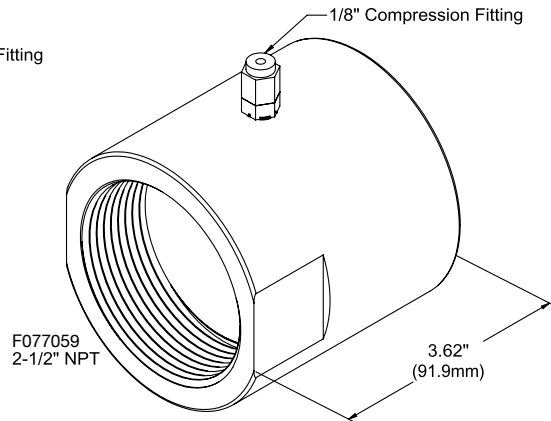
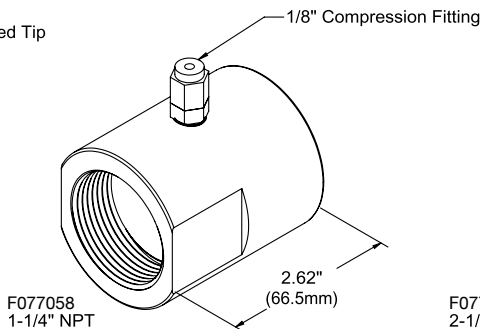
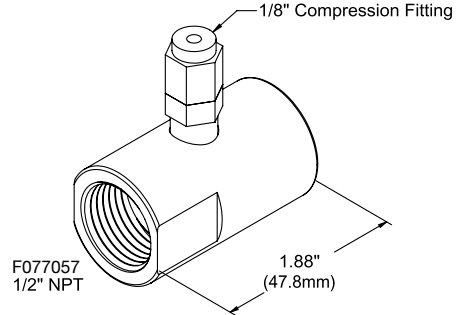
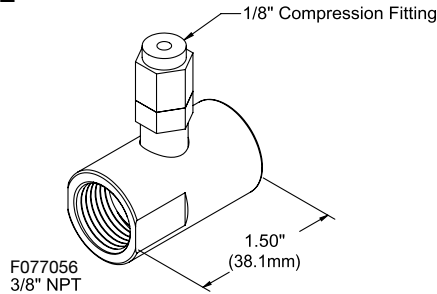

Threaded In-line Thermocouple Adapters

Part Number	Description
F077056	TC Adapter 3/8" Threaded In-line
F077057	TC Adapter 1/2" Threaded In-line
F077058	TC Adapter 1-1/4" Threaded In-line
F077059	TC Adapter 2-1/2" Threaded In-line
F206119	1/8" TC Type K 12" Probe

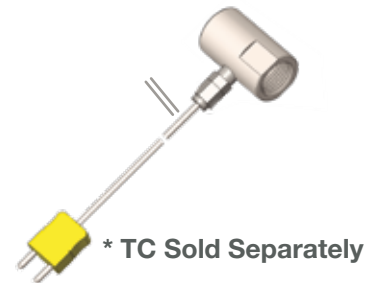

Notes:

- Threaded In-line thermo couple adapter material is 316 stainless steel
- Better resistance to oxidation at higher temperatures
- Type K thermocouple F206119 sold separately
- Use of other sensor types and mounting locations can result in heater damage
- Thermocouple mounting depth location is critical. Follow all mounting instructions.
- If replacing a Thermocouple, take note of the depth by measuring the distance to the compression fitting on the old Thermocouple.

Thermocouple Installation Reference

2-1/2" NPT Threaded In-line
Heater Assembly Part Number:
F074439

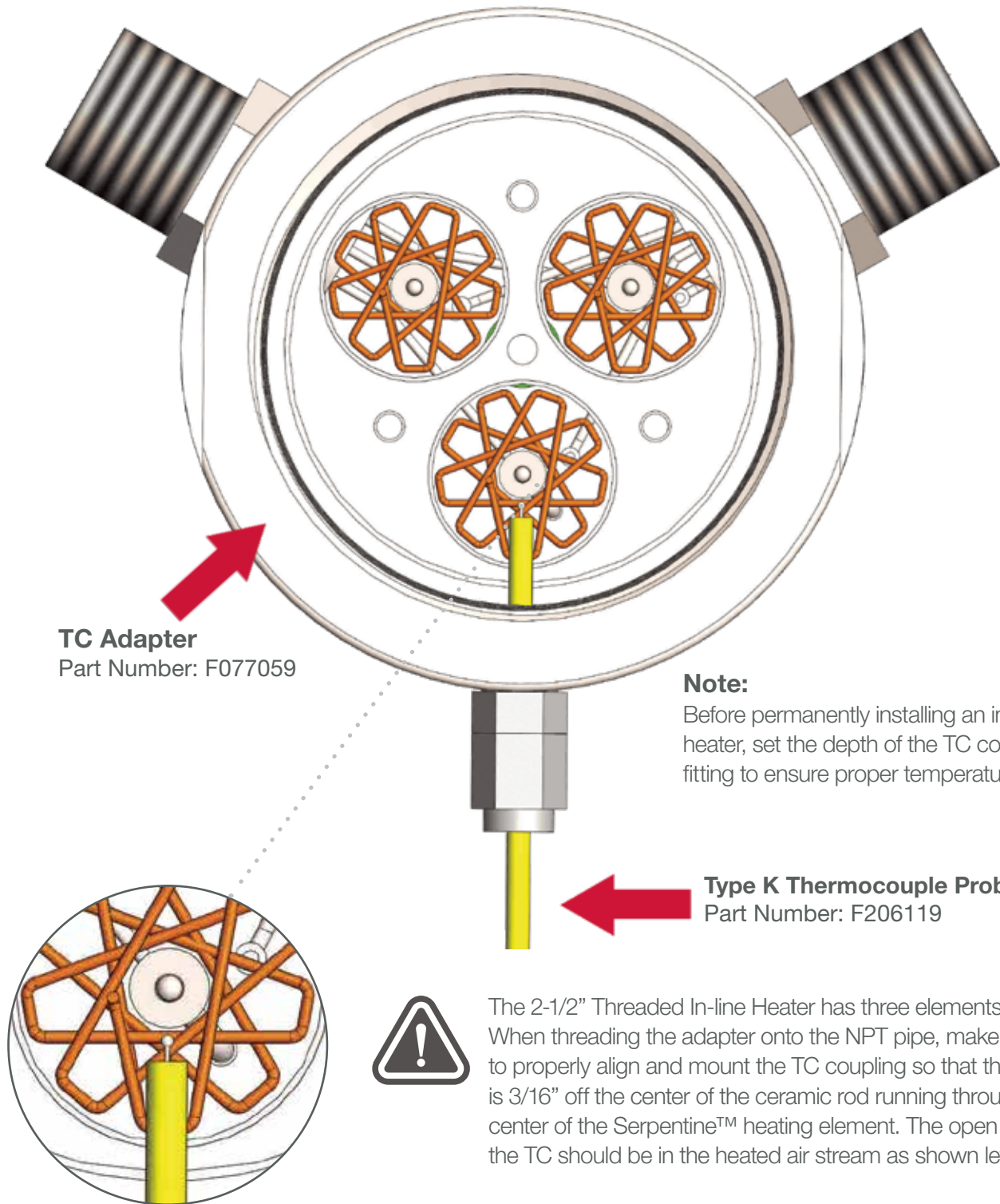

TC Adapter
Part Number: F077059

Note:
Before permanently installing an in-line heater, set the depth of the TC compression fitting to ensure proper temperature control.

Type K Thermocouple Probe
Part Number: F206119



The 2-1/2" Threaded In-line Heater has three elements. When threading the adapter onto the NPT pipe, make sure to properly align and mount the TC coupling so that the TC is 3/16" off the center of the ceramic rod running through the center of the Serpentine™ heating element. The open end of the TC should be in the heated air stream as shown left.

Dimensions / Installation Reference

3/8" THREADED INLINES

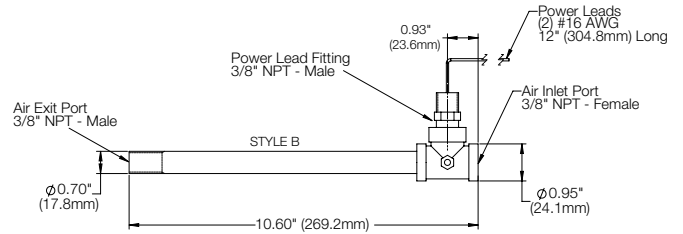
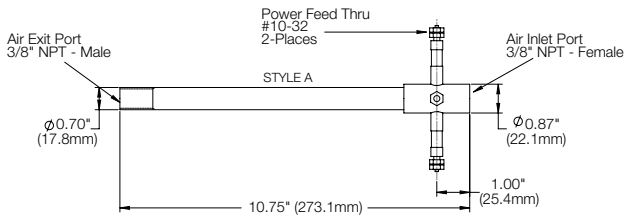

1/2" THREADED INLINES

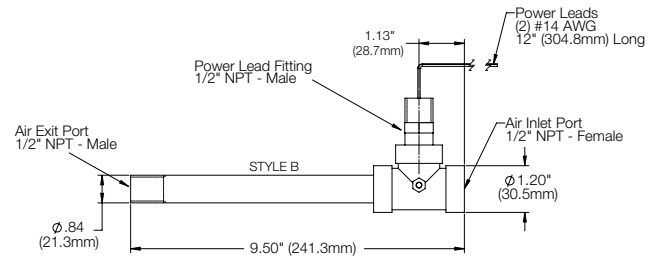
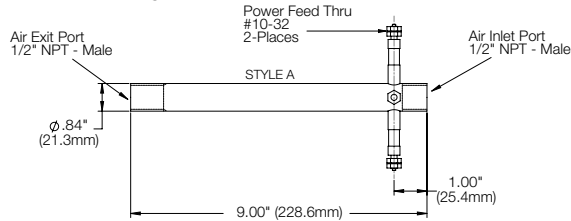

1-1/4" THREADED INLINES

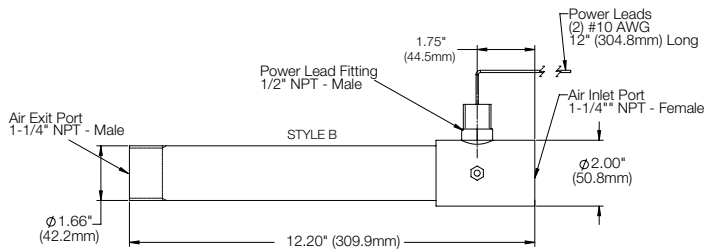
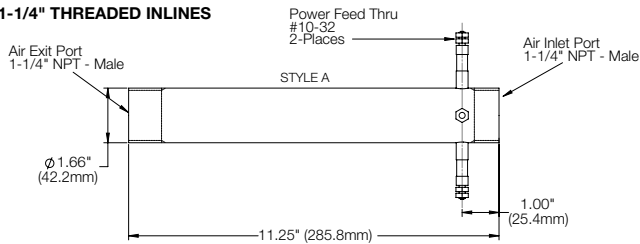

2-1/2" THREADED INLINES

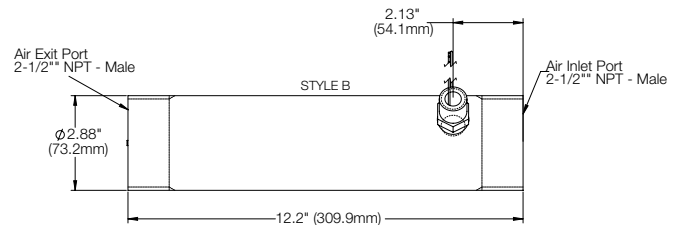
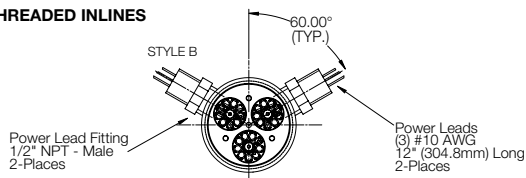

Threaded In-line Products

Size (NPT)	Max. Power	Max.Volts	Max. Amps	P/N, Style "A"	P/N, Style "B"
3/8"	1.6kW	170	9.4	F038821	F038822
1/2"	4.0kW	220	18.2	F038823	F038824
1-1/4"	6.0kW	220	27.3	F038825	F038826
1-1/4"	8.0kW	240	33.3	F077065	F077028
2-1/2"	18.0kW	240	75.0 (1ø)/44.0 (3ø)	N/A	F063007
2-1/2"	18.0kW	480	21.7 (3ø)	N/A	F076418
2-1/2"	24.0kW	240	100.0 (1ø)/57.8 (3ø)	N/A	F074439

Style A / Style B Installation Reference

Style A Threaded In-line Products

- UL Recognized
- High-pressure power feed throughs
- Leak-proof to 150 psi (10 bar)
- Maximum inlet temperatures 900°F (482°C)
- Torque Specification for power connections 20 lb-in (2.26 N-m)



The inlet side of the heater is located closest to the power feed throughs. Installation orientation is critical. Positioning the heater in the wrong direction will cause damage. Like all Tutco SureHeat products, do not operate without air flow.



Style B Threaded In-line Products

- UL Recognized
- 12" (305mm) flexible wire power leads
- Not recommended for leak-proof systems due to slight leakage through wire strands
- Maximum inlet temperatures 200°F (93°C)

Threaded In-line Performance Curves

Threaded Inline Maximum Performance

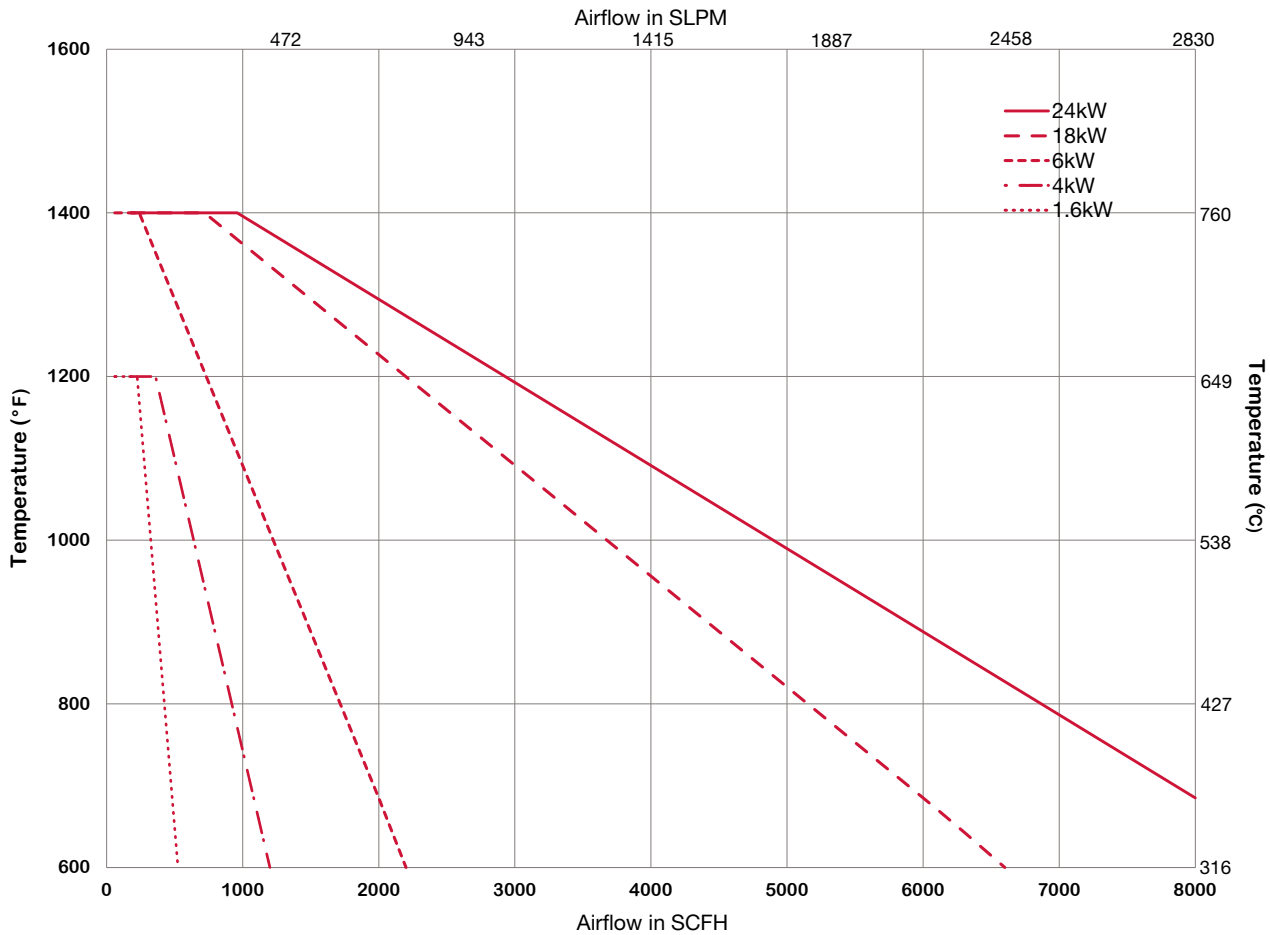

Notes:

- Temperatures are measured by 3/16" "K"
- Use of other sensor types and mounting locations can result in heater damage
- Minimum airflow for accurate control is 60 SCFH
- Maximum air temperature is 1400°F (760°C)
- Operating above this curve voids the product warranty



Jet Air Heater

General Description

The JET provides a compact and efficient heater solution for air temperatures up to 1400°F (760°C). Available in a 3.0kW or 8.0kW, 240V 1Ø unit, the Jet offers two type “K” thermocouples with a convenient terminal block for easy wiring. To ensure safety, power and perfect control, connect with the optional Jet Control Panel. Each heater has a convenient method for mounting the housing and offers a ground stud located at the inlet of the heater.

Closed-Loop Connection Diagram

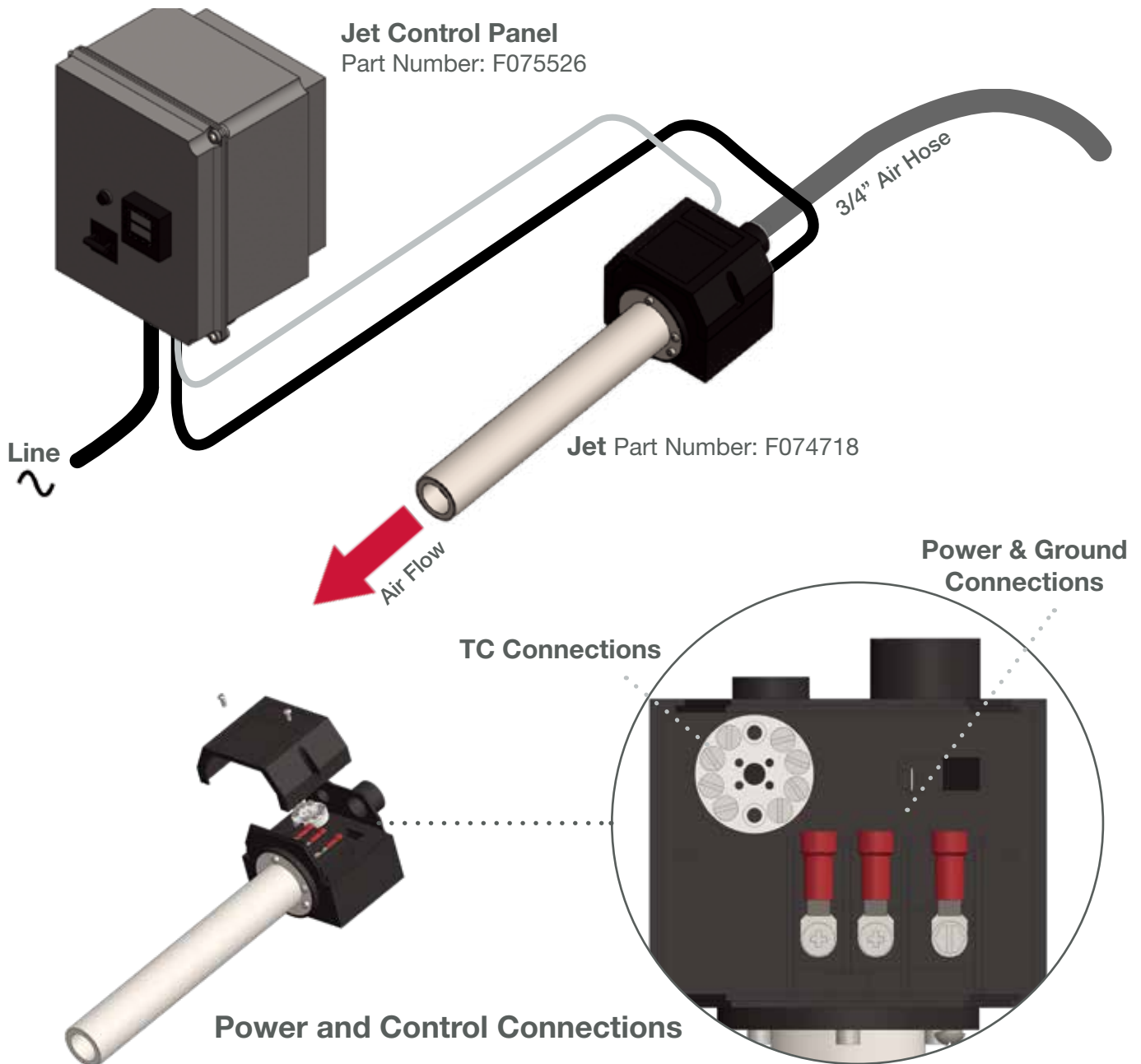

Dimensions / Installation Reference

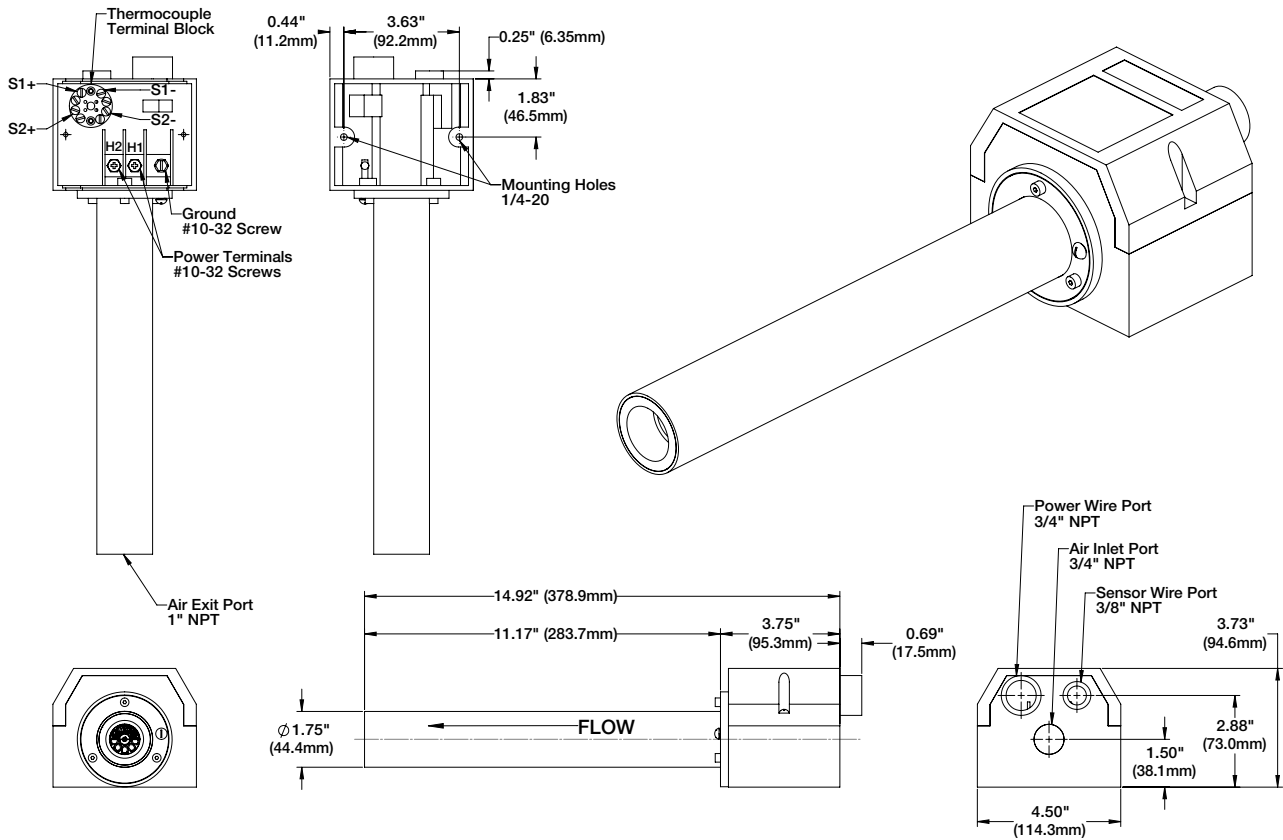

Jet Products

Part Number	Power kW	Max. Volts / ø	Max. Amps
F074718	3.0	240 / 1	12.5
F074719	8.0	240 / 1	33.3

Jet Control Products

F075526	8.0	240 / 1	40
---------	-----	---------	----

Jet Performance Curve

Jet Maximum Performance

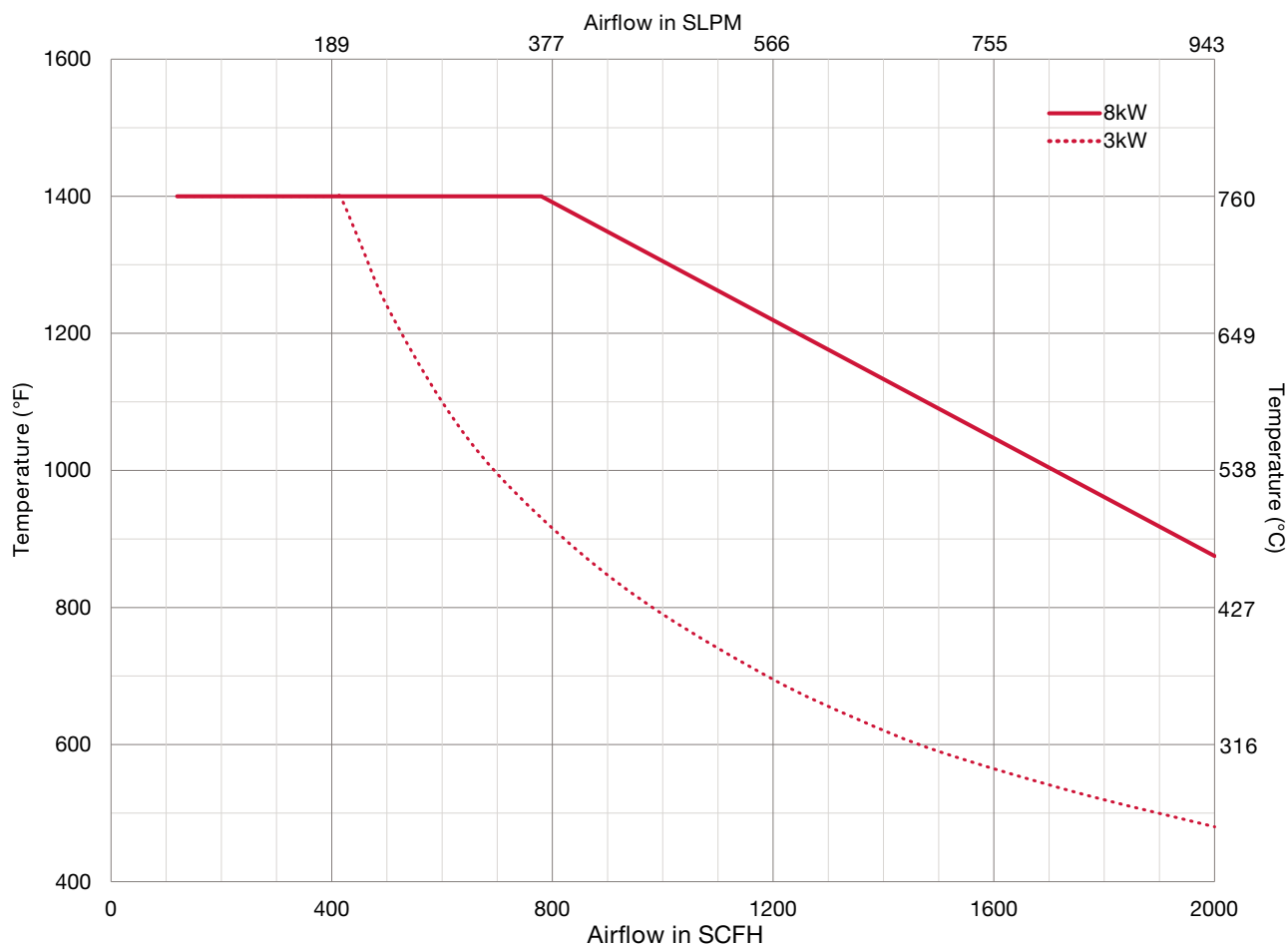

Notes:

- Temperatures are measured by internal “K” T/C sensors located inside the Jet Housing
- Use of other sensor types and/or locations can result in heater damage
- Minimum airflow for accurate control is 2 SCFM
- Maximum air temperature is 1400°F (760°C)
- Operating above temperature voids the product warranty



Max Air Heater

General Description

The Max provides a compact and efficient heater solution for air temperatures up to 1400°F (760°C). Available in a 6.0kW to 36.0kW, 240V/380V/480V 1 ϕ / 3 ϕ units, the Max offers two type “K” thermocouples with a convenient terminal block for easy wiring. To ensure safety, power and perfect control, connect with the optional Max Control Panel. Each heater has a convenient method for mounting the housing and offers a ground stud located at the inlet of the heater.

Closed-Loop Connection Diagram

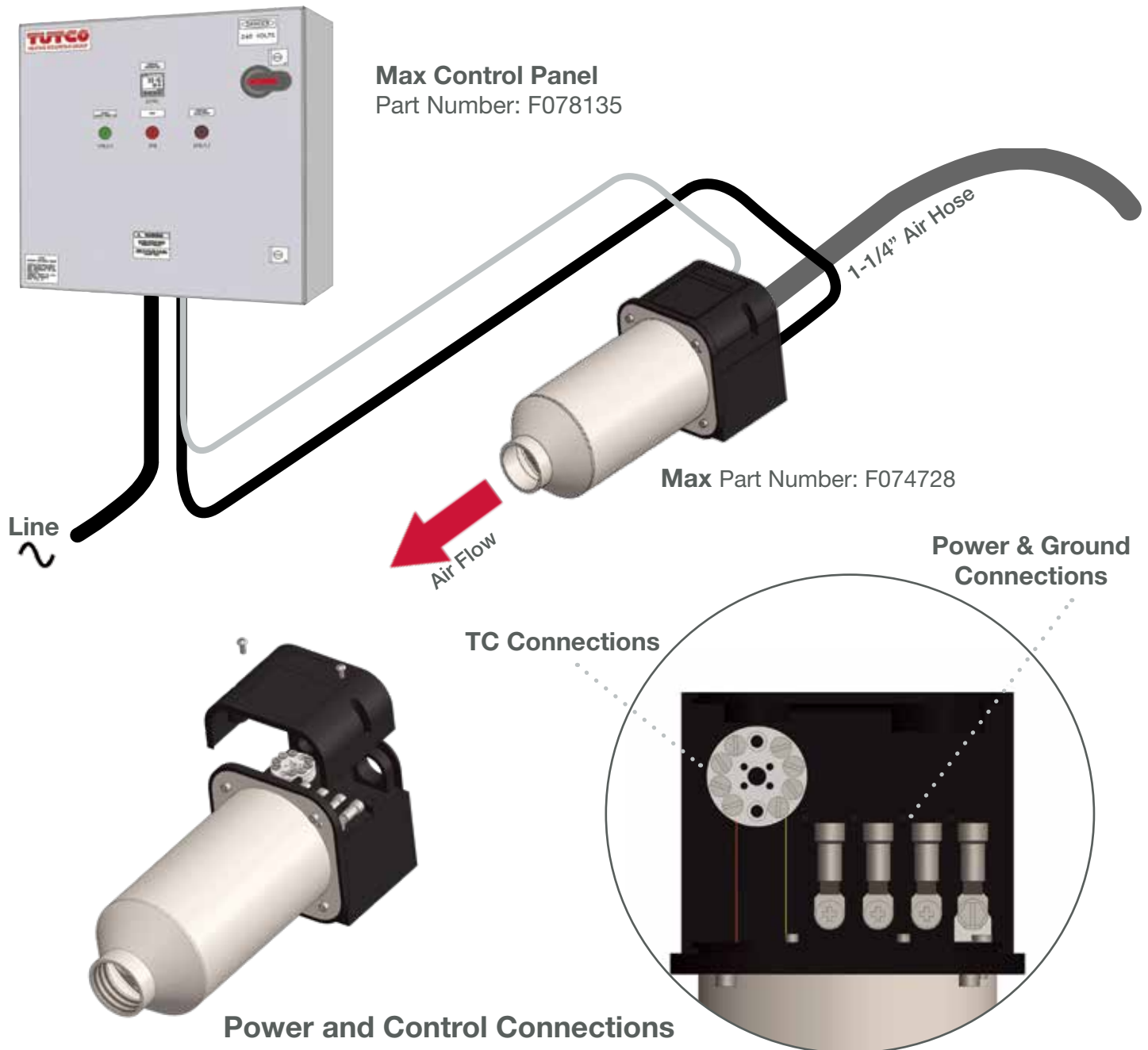

Dimensions / Installation Reference

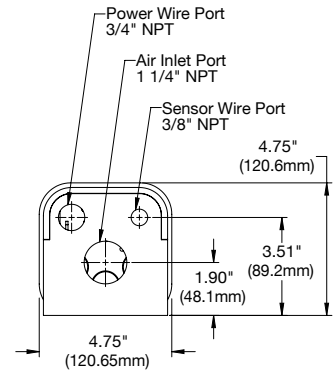
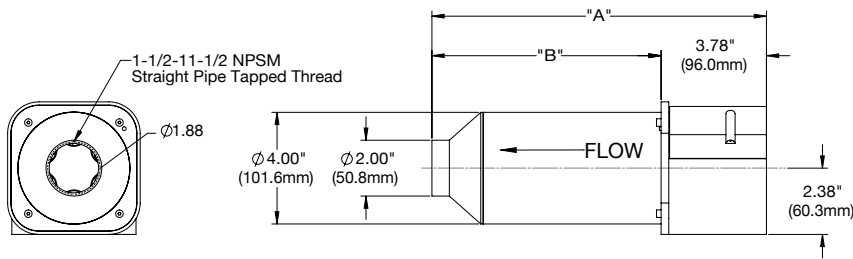
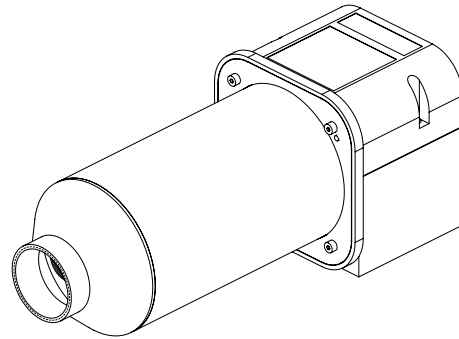
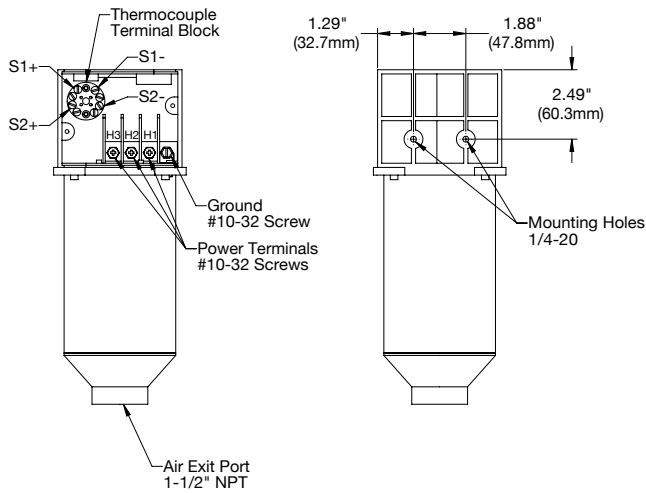

SureHeat® Max Products

Part Number	Power kW	Max. Volts / ϕ	Max. Amps	Dim "A" "(mm)	Dim "B" "(mm)
F074723	6.0	240 / 1	25	12 (304.8)	8.21 (208.53)
F074724	6.0	240 / 3	14.5	12 (304.8)	8.21 (208.53)
F074725	6.0	380 / 3	9.1	12 (304.8)	8.21 (208.53)
F074726	6.0	480 / 3	7.2	12 (304.8)	8.21 (208.53)
F074727	10.0	240 / 1	41.7	12 (304.8)	8.21 (208.53)
F074728	10.0	240 / 3	24.1	12 (304.8)	8.21 (208.53)
F074729	10.0	380 / 3	15.2	12 (304.8)	8.21 (208.53)
F074731	10.0	480 / 3	12.0	12 (304.8)	8.21 (208.53)
F074732	18.0	240 / 3	43.4	16 (406.4)	12.21 (310.2)
F074733	18.0	380 / 3	27.4	16 (406.4)	12.21 (310.2)
F074734	18.0	480 / 3	21.7	16 (406.4)	12.21 (310.2)
F074735	30.0	380 / 3	45.6	16 (406.4)	12.21 (310.2)
F074736	36.0	480 / 3	43.4	16 (406.4)	12.21 (310.2)

Max Performance Curve

MAX Maximum Performance

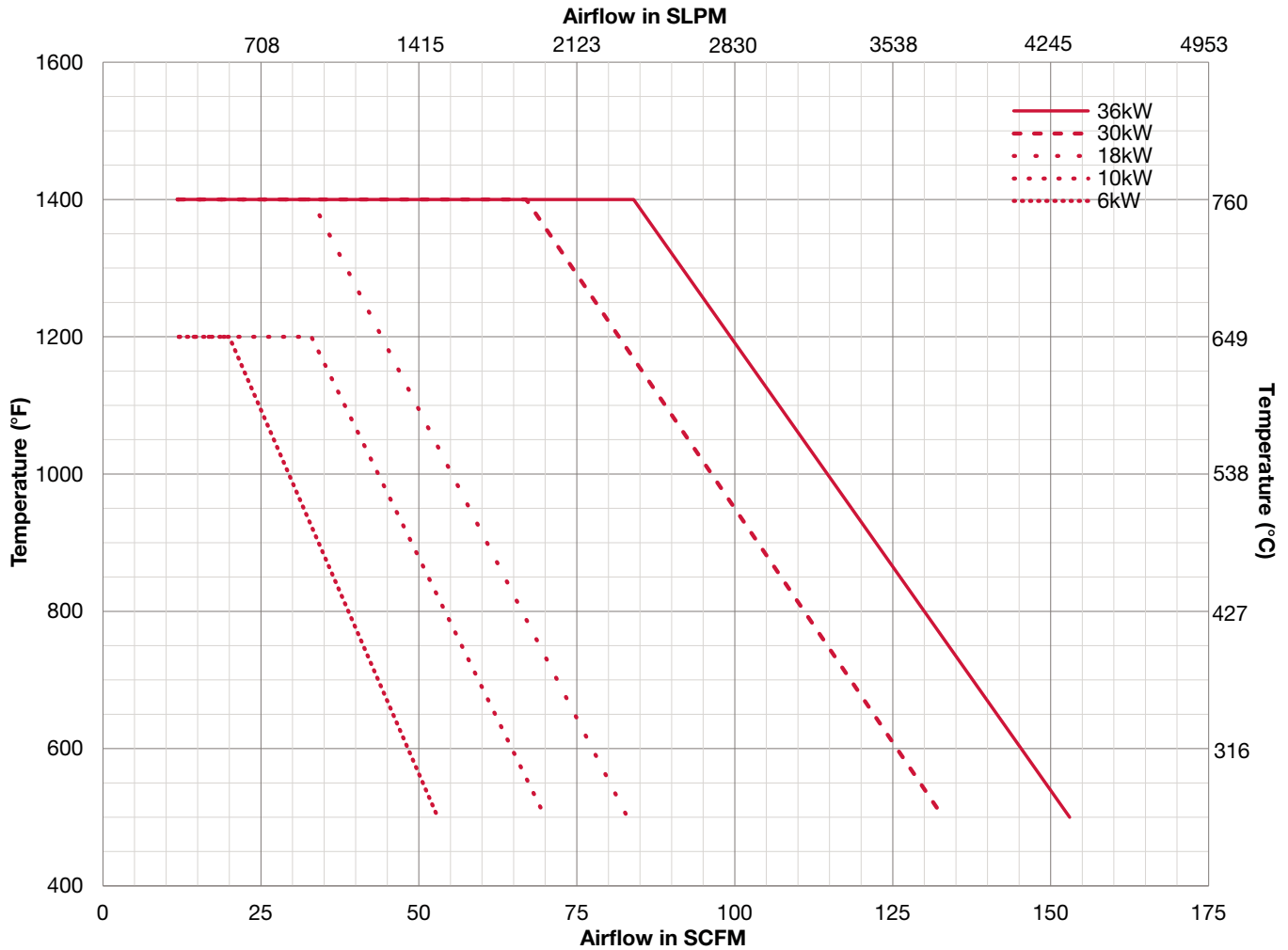

Notes:

- Temperatures are measured by internal “K” T/C sensors located inside the Max Housing
- Use of other sensor types and/or locations can result in heater damage
- Minimum airflow for accurate control is 12 SCFM
- Maximum air temperature up to 1400°F (760°C)
- Operating above temperature will void the warranty



Max HT Air Heater

General Description

The Max HT provides a compact and efficient heater solution for high temperature applications up to 1652°F (900°C). A dual type “K” thermocouple with a convenient terminal block is included for ease of wiring. Each exposed thermocouple is used to measure inlet and exit air temperature. One is typically used for process temperature control and the other to monitor high temperature limit. Each heater has a convenient method for mounting the housing and offers a ground stud located at the inlet of the heater.

Closed-Loop Connection Diagram

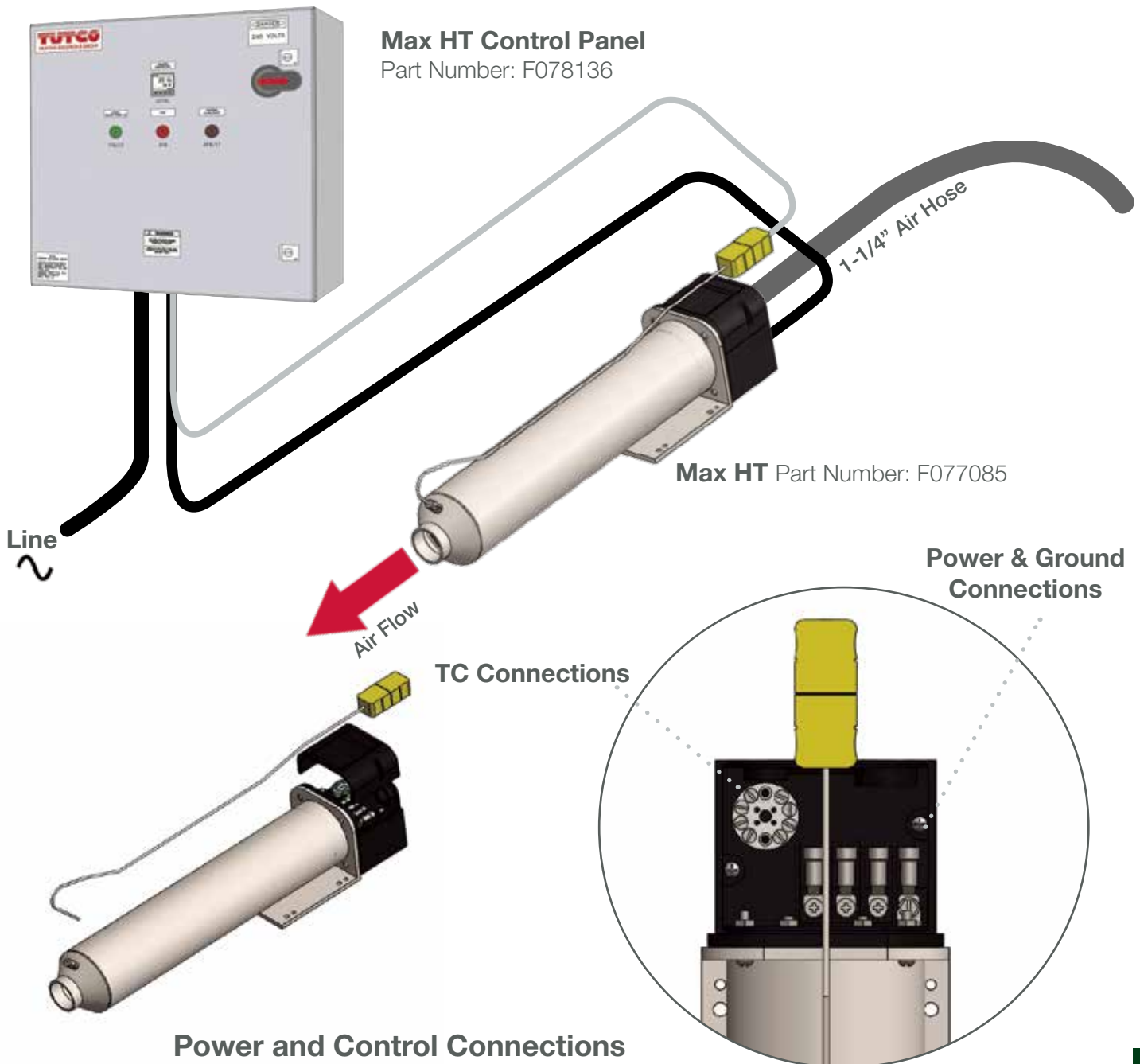

Dimensions / Installation Reference

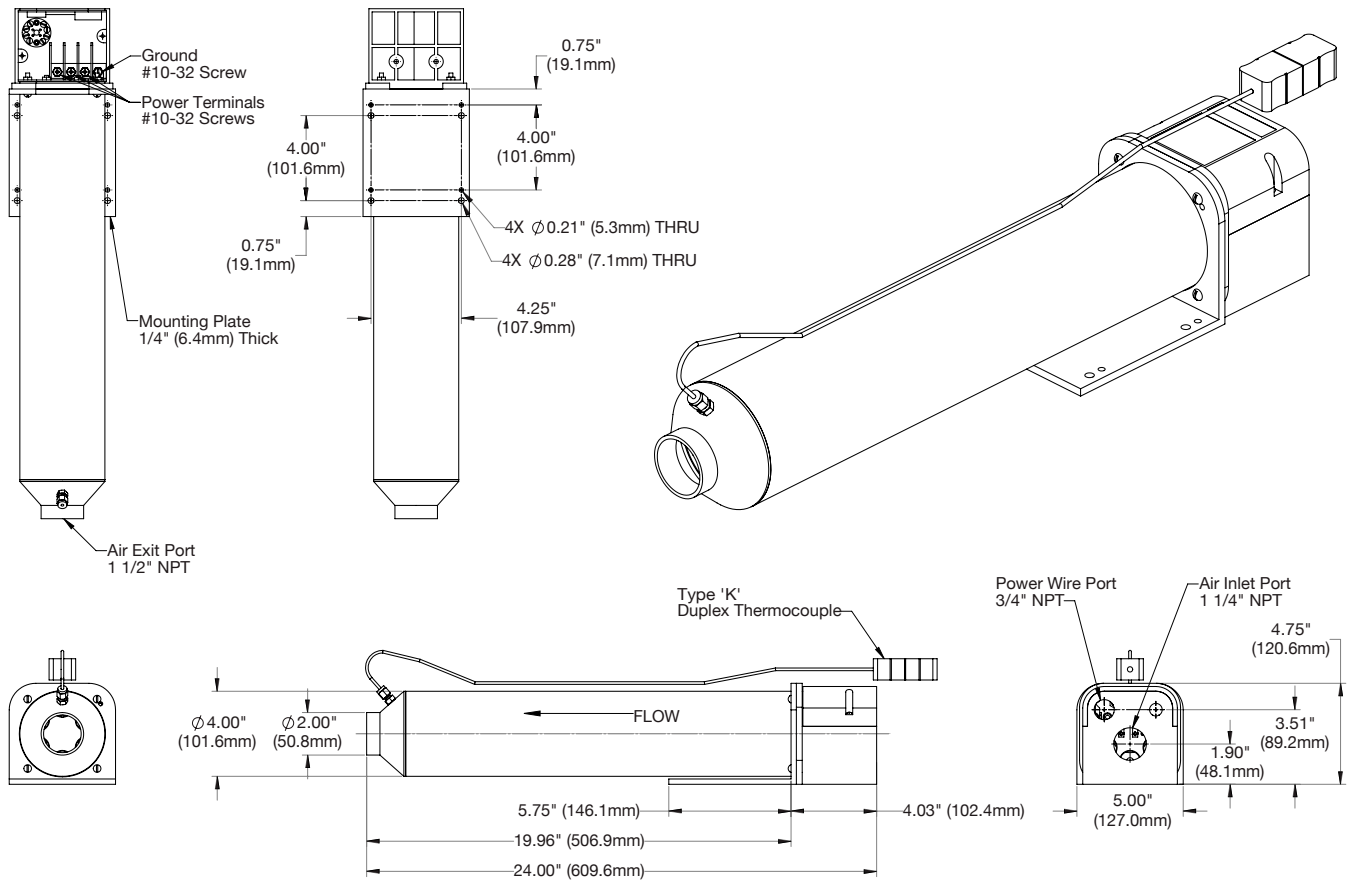

SureHeat® Max HT Products

Part Number	Power kW	Max. Volts / ϕ	Max. Amps	Replacement Element
F077081	18.0	240 / 3	43.4	F206707
F077082	18.0	380 / 3	27.4	F206662
F077083	18.0	480 / 3	21.7	F206663
F077084	30.0	380 / 3	45.6	F206664
F077085	36.0	480 / 3	43.4	F206598



SureHeat[®] Max HT Performance Curve

MAX-HT Maximum Performance

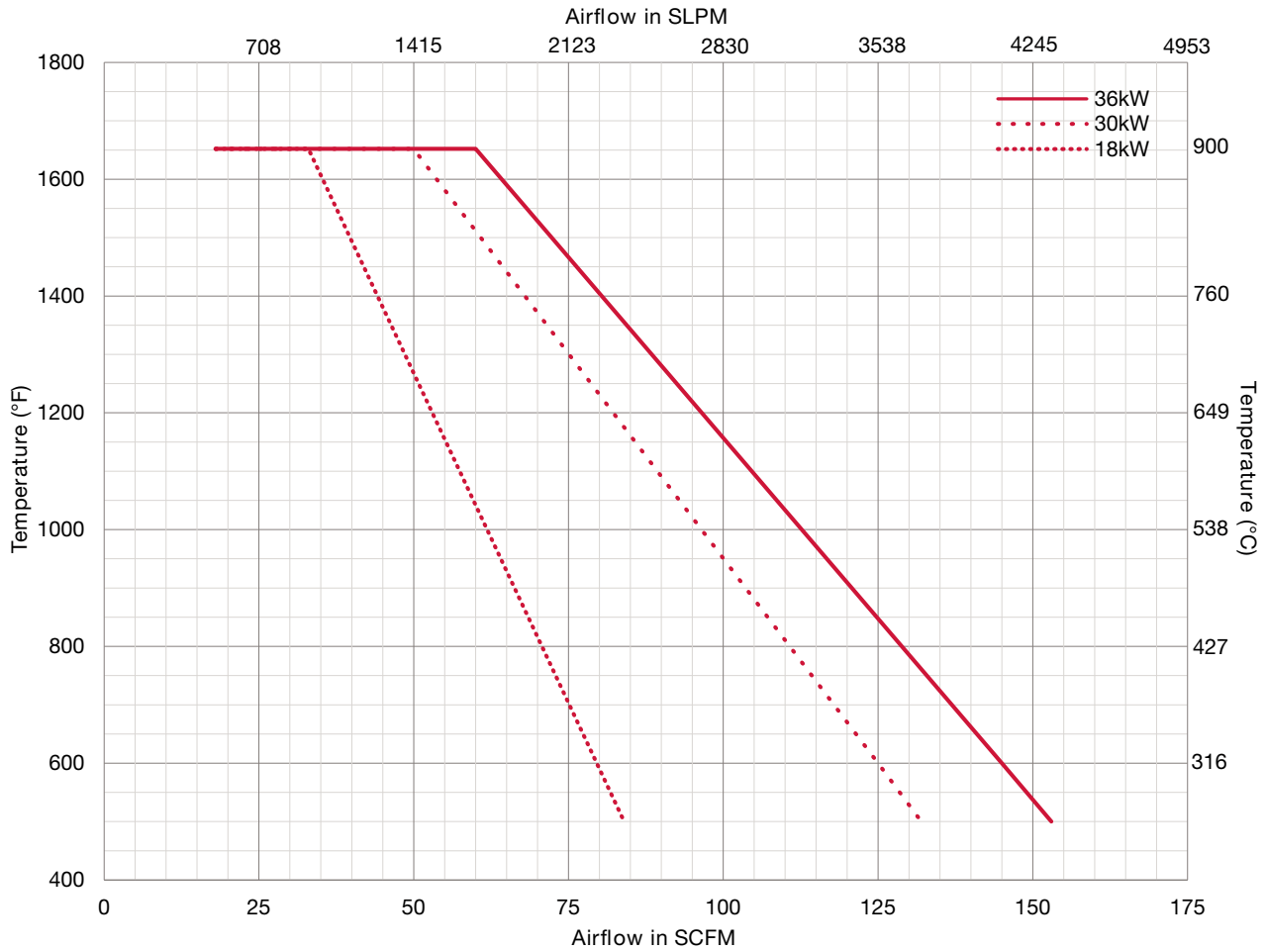

Notes:

- Temperature is measured by a dual “K” T/C sensor located inside the Max HT Housing
- Use of other sensor types and/or locations can result in heater damage
- Minimum airflow for accurate control is 18 SCFM
- Maximum air temperature is 1652°F (900°C)
- Operating above temperature will void the warranty



Troubleshooting Heaters

1. Heater element life is dependent on proper control and element wire temperature. The estimated life-cycle is based on the heater element operating at or below temperatures specified. Most element failures are due to low air flow or damage associated to power control and voltage ramp up rates.
2. If an element has failed prematurely, it should be inspected to determine the cause of the failure.
3. Determining the cause will prevent the same problem from reoccurring.
4. When replacing or troubleshooting heaters, turn off the power and be sure to follow all lock-out / tag-out electrical panel procedures.
5. With the power off, and the heater disconnected, use a multimeter to check continuity between the heater power terminals. (H1/H2, H2/H3 and H1/H3)
6. If there is no continuity, please contact Tutco SureHeat technical support for assistance.
7. If there is continuity on all of the above tests, please check the system wiring.
8. Crossed thermocouple wires, reversed thermocouple wiring and incorrect air inlet temperature settings can cause undesired operation. If you discover a wiring issue, resolve it, reconnect and test the heater.
9. Verify thermocouple wiring, (+ yellow and - red)
10. Verify that the inlet air temperature is below the set point on the inlet temperature controller.

Identifying Overshoot Element Damage

Overshoot damage with airflow present



Note:

Overshoot can occur even with airflow present. Damage by overshoot is easily identified because it occurs near the air exit end of the heater. See photo examples to the left.

Overshoot damage without airflow present



Before installing a replacement, it is important to correct the voltage overshoot.

Determining Process Air Heater Needs

Custom solutions are available

Please use the form below to determine your air heater requirements.

Type of Application:					
Mass Airflow Rate:	<input type="checkbox"/> SCFM	<input type="checkbox"/> Lbs/min	<input type="checkbox"/> Kg/sec	<input type="checkbox"/> Other _____	
Air (Gas) Supply:	<input type="checkbox"/> Air Compressor	<input type="checkbox"/> Blower / Fan			
System Air Pressure:	<input type="checkbox"/> PSI	<input type="checkbox"/> Bar	<input type="checkbox"/> Other _____		
Inlet Air Temperature:	<input type="checkbox"/> °F Fahrenheit	<input type="checkbox"/> °C Celsius	<input type="checkbox"/> °K Kelvin		
Exit Air Temperature:	<input type="checkbox"/> °F Fahrenheit	<input type="checkbox"/> °C Celsius	<input type="checkbox"/> °K Kelvin		
Type of Air (Gas) Heated:					
Power Available:	<input type="checkbox"/> 120V	<input type="checkbox"/> 208V-240V	<input type="checkbox"/> 380V-400V	<input type="checkbox"/> 480V	<input type="checkbox"/> Other _____
	<input type="checkbox"/> 1Ø	<input type="checkbox"/> 3Ø			

Optional Information

While not required, this information can help you consider variables and challenges during the installation phase.

Max. System Air Pressure Drop:	<input type="checkbox"/> PSI	<input type="checkbox"/> Bar	<input type="checkbox"/> Other _____
Expected Heater Run-Time: (hrs/day)			
Required Heater Ramp-Up Time:			
Heater Mounting Requirements:			
Heater Nozzle Requirements:			
Special Safety Requirements:			
Submit to: support@tutcosureheat.com			

Reference Data

Air Heater Power Requirement

$$kW = SCFM \times (\text{Exit Temp} - \text{Inlet Temp}) / 2500$$

or

$$kW = SCFM \times (\text{Exit Temp} - \text{Inlet Temp}) / 3000 \times 1.2$$

Air Flow Conversions

$$SCFM = SCFH / 60 = SLPM / 28.3$$

$$SLPM = SCFH / 2.12$$

$$SCMH = SCFH / 35.3$$

$$SCFM = (\text{pounds of air per minute}) / (0.076 \text{ lbs} / \text{ft}^3)$$

$$SCFM = \text{grams} / \text{sec} \times 1.74$$

$$SCFM = \text{kg} / \text{min} \times 28.9$$

Single Phase Wiring

$$V = I \times R \text{ (Volts = Amps} \times \text{Ohms)}$$

$$I = W / V \text{ (Amps = Watts / Volts)}$$

$$W = V^2 / R \text{ (Watts = (Volts} \times \text{Volts) / Ohms)}$$

Three Phase Delta Wiring

$$R = R_1 = R_2 = R_3$$

$$W_{\text{delta}} = 3 (V_L^2) / R$$

$$W_{\text{delta}} = 1.73 \times V_L \times I_L$$

$$IP = I_L / 1.73$$

$$VP = V_L$$

Three Phase Wye Wiring

$$R = R_1 = R_2 = R_3$$

$$W_{\text{wye}} = (V_L^2) / R = 3 (V_P^2) / R$$

$$W_{\text{wye}} = 1.73 \times V_L \times I_P$$

$$IP = I_L$$

$$VP = V_L / 1.73$$

Temperature Conversions

$$^{\circ}\text{F} = 9/5 (^{\circ}\text{C} + 32) \text{ or } ^{\circ}\text{F} = ^{\circ}\text{C} \times 1.8 + 32$$

$$^{\circ}\text{C} = 5/9 (^{\circ}\text{F} - 32) \text{ or } ^{\circ}\text{C} = ^{\circ}\text{F} - 32 / 1.8$$

Air Flow Abbreviations

SCFM = standard cubic feet per minute
 SCFH = standard cubic feet per hour
 SLPM = standard liters per minute
 SCMH = standard cubic meters per hour

Thermocouple Wiring / Configuration Type K

(+) = Yellow = Alumel (non-magnetic)
 (-) = Red = Chromel (magnetic)

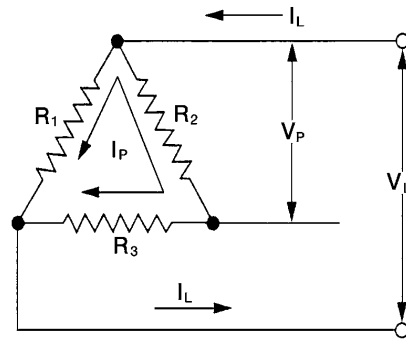

Delta Wiring Configuration

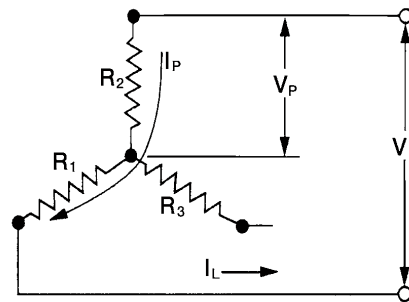

Wye Wiring Configuration

Contact Information

For Orders and Product Information



22 Industrial Drive
Exeter, NH 03833

Direct: +1.603.418.7662
Toll-Free: +1.800.258.8290

Support Email: support@tutcosureheat.com
For Orders and Sales Inquiries: orders@tutcosureheat.com

Limited Liability Warranty

Tutco SureHeat warrants that all products to be delivered hereunder will be free from defects in material and workmanship at the time of delivery. Tutco SureHeat's obligation under this warranty shall be limited to (at its option) repairing, replacing, or granting a credit at the prices invoiced at the time of shipment for any of said products. This warranty shall not apply to any such products which shall have been repaired or altered, except by Tutco SureHeat.

Tutco SureHeat shall be liable under this warranty only if (A) Tutco SureHeat receives notice of the alleged defect within sixty (60) days after the date of shipment; (B) the adjustment procedure hereinafter provided is followed, and (C) such products are, to Tutco SureHeat's satisfaction, determined to be defective.

THE WARRANTY SET FORTH IN THE PRECEDING PARAGRAPH IS EXCLUSIVE AND IN LIEU OF ALL OTHER WARRANTIES, EXPRESS OR IMPLIED, INCLUDING, WITHOUT LIMITATION, ANY IMPLIED WARRANTY OF FITNESS FOR A PARTICULAR PURPOSE OR OF MERCHANTABILITY.

The information contained in this manual is based on data considered to be true and accurate. Reasonable precautions for accuracy has been taken in the preparation of this manual, however Tutco SureHeat assumes no responsibility for any omissions or errors, nor assumes any liability for damages that may result from the use of the product in accordance with the information contained in this manual.

Please direct all warranty/repair requests or inquiries to the place of purchase, and provide the following information, in writing:

- (A) Order number under which products were shipped
- (B) Model/Serial Number of product
- (C) Reason for rejection

Products can not be returned to Tutco SureHeat without authorization. Replacement, repair, or credit for products found to be defective will be made by the place of purchase. All products found to be not defective will be returned to the buyer; transportation charges collect or stored at buyers expense.

Worldwide Locations



Tutco Heating Solutions Group North American Headquarters

500 Gould Drive
Cookeville, TN 38506
www.tutco.com

Tutco SureHeat

22 Industrial Drive
Exeter, NH 03833
www.tutcosureheat.com

Your Tutco SureHeat Distributor:

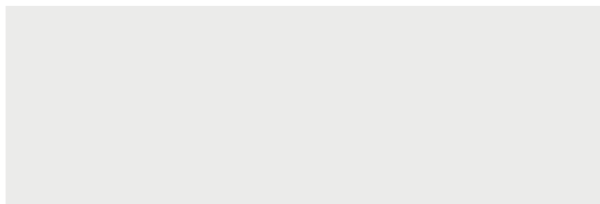

Distribution Locations:

Albania	Hong Kong	Romania
Austria	India	Russia
Australia	Indonesia	Saudi Arabia
Belarus	Italy	Shanghai
Belgium	Japan	Singapore
Bosnia	Kenya	Slovak Republic
Canada	Korea	Slovenia
China	Latvia	South Africa
Chile	Lithuania	Spain
Croatia	Luxembourg	Sweden
Denmark	Mexico	Switzerland
Estonia	Moldova	Taiwan
Finland	Netherlands	Thailand
France	Norway	Turkey
Germany	North Africa	Ukraine
Great Britain	Philippines	United Arab Emirates
Greece	Poland	United States of America
Hungary	Portugal	Vietnam

Tutco is a registered trademark of Smiths Group
SureHeat is a registered trademark of the Tutco Heating Solutions Group
All other trademarks are those of their respective owners
© 2020 Tutco SureHeat .

The information and recommendations in this publication are based upon data collected by Tutco SureHeat and believed to be correct. However, no guarantees or warranties of any kind, expressed or implied, is made with respect to the information contained herein, and Tutco SureHeat assumes no responsibility for the results of the use of products and processes described herein. No statements or recommendations made herein are to be construed as inducements to infringe any relevant patent, now or hereafter in existence.