

VRF outdoor units



Selection guide

VRF system

1 OUTDOOR UNITS

2 COOLING CAPACITY

OUTDOOR UNITS	Hp													
	4	5	6	8	10	12	14	16	18	20	22	24	72	96
Micro VRF (IVX Prime & IVX Comfort)  Refrigerant R32 (4-6 Hp) Refrigerant R410A (4-12 Hp)	•	•	•	•	•	•								
SET FREE Mini  Refrigerant R410A	•	•	•	•	•	•								
SET FREE Sigma Standard  Refrigerant R410A				•	•	•	•	•	•	•	•	•	•	•
SET FREE Sigma High-performance  Refrigerant R410A		•	•	•	•	•	•	•	•	•	•	•	•	
VRF IVX Centrifugal  Refrigerant R410A	•	•	•	•	•									

Controls

Individual controls



PC-ARFP1E (hard wired)



PC-ARH1E (simplified wired)



PC-AWR (infrared)

Central controls



PSC-A32MN (touch)



PSC-A64GT (touch)



Aircloud Pro



CSNET Lite (web)



CSNET Screenless (web)







CSNET Manager 2T10 (web and touch)



CSNET Manager 2T15 (web and touch)

3 FEATURES

4 INDOOR UNITS

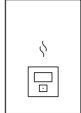
Technology	Supply voltage	Connection rate range	Max. number of connected indoor units	Min. power of connected indoor units	Max. pipe length	Max. level difference between outdoor unit and indoor unit (outdoor unit above / below)	Max. level difference between indoor units	Operating ranges	INDOOR UNITS
Single split or 2-pipe VRF	400V/3/50Hz and 230V/1/50Hz (depending on the model)	90 - 115%* depending on the application	4	0.8 Hp (2 kW cooling)	50 to 100 m	30 m / 20 m	3 m	Heating -20° ~ 18°C WB cooling -5°C (-15°C: optional) ~46°C DB	<div style="display: flex; justify-content: space-around;"> <div style="border: 1px solid black; border-radius: 50%; padding: 2px;">1.1 to 56 kW</div> <div style="border: 1px solid black; border-radius: 50%; padding: 2px;">+100 models</div> </div>  <p>Cassette units</p>
2-pipe & 3-pipe heat recovery VRF (depending on the model)	400V/3/50Hz and 230V/1/50Hz (depending on the model)	50 - 130%	39	0.4 Hp (1.1 kW cooling)	85 to 125 m	50 m / 40 m (depending on the model)	15 m	Heating -20° ~ 15°C WB Cooling -5° ~ 48°C DB	 <p>Ducted</p>
2-pipe & 3-pipe heat recovery VRF	400V/3/50Hz	50 - 130%	64	0.4 Hp (1.1 kW cooling)	165 m	50 m / 40 m	30 m	Heating -20° ~ 15°C WB Cooling -10° ~ 48°C DB	 <p>Wall unit</p>
2-pipe & 3-pipe heat recovery VRF	400V/3/50Hz	50 - 150%* depending on the application	64	0.4 Hp (1.1 kW cooling)	165 m	50 m / 40 m	30 m	Heating -20° ~ 15°C WB Cooling -10° ~ 52°C DB	 <p>Console</p>  <p>Ceiling unit</p>
Single split or 2-pipe VRF	400V/3/50Hz	75 - 120%	6	0.8 Hp (2 kW cooling)	75 to 100 m (depending on the model)	30 m / 20 m	10 m	Heating -15° ~ 15°C WB Cooling -5° ~ 46°C DB	 <p>Hydrafree module</p>

* Please refer to the technical documentation for more details on the combinations allowed.

Communication protocol



MODBUS



BACNET



KNX



LONWORKS

Hitachi exclusive features

Set Free Mini VRF with heat recovery (8 to 12Hp)

The most compact 3-pipe VRF in the world!

EXCLUSIVE TO
HITACHI

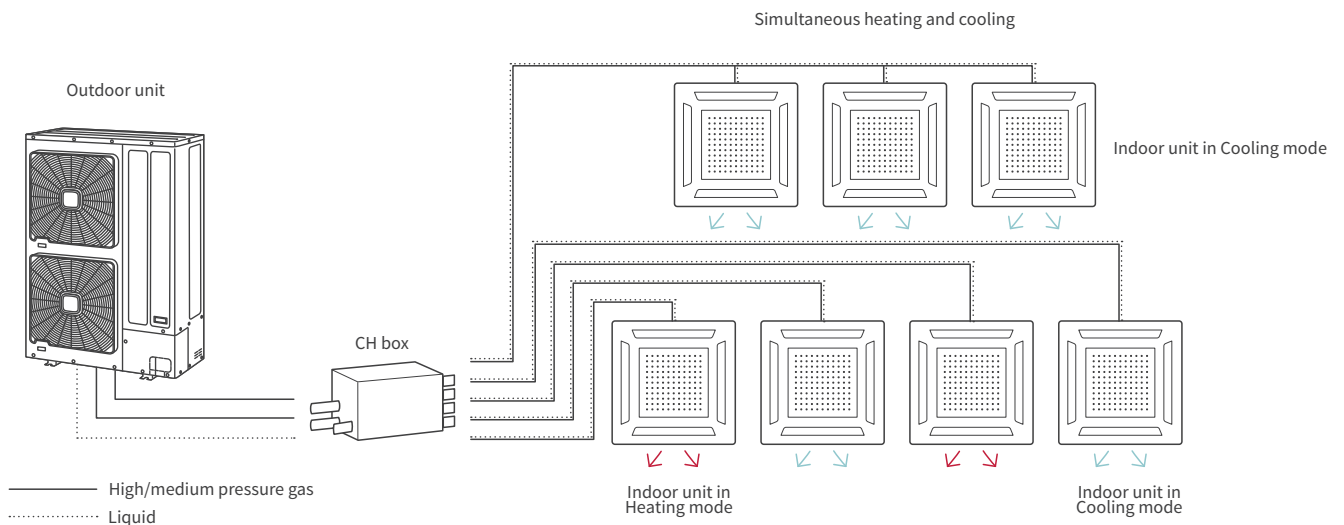

The + points of the Hitachi solution

Energy recovery box

- No addressing to do on our CH boxes.
- **Low noise level: down to 31 dB(A) on multi-box and 33 dB(A) on single-box.**
- **The most compact on the market: Single box HxWxD: 191x301x214, multi box HxWxD: 260x303x352.**
- **Install in a corridor to ease distribution to indoor units.**
- Positioning the CH box close to the units reduces the complexity of the pipe networks and therefore uses less refrigerant.
- Electronic expansion valves in the boxes: more gradual opening to limit noise levels.
- **Optimal operation:** the CH box provides heating and cooling air simultaneously without the need for a minimum % of units being in each mode. 1 unit can be in cooling mode while the rest are in heating mode. Traditional solutions need a cooling demand of 25% or 30% to unlock simultaneous controls.
- **No condensate connection!**
- Box connections provided with flare connection: ideal for sensitive areas where there is a risk of fire ... can be brazed onsite if necessary.

Set Free Mini 8 to 12Hp

- Outdoor unit with low amount of refrigerant: 8Hp (pre-charged with 4.2kg), 10 and 12Hp (pre-charged with 5.5kg).
- Meets EN 378 relating to the level of gas concentration in the premises.
- Small footprint: up to 37% less compared to top flow VRF.
- Easy to install: on a balcony, big-foot support, wall-mounted on the façade with brackets.
- Great flexibility: up to 500m length of piping.
- Low noise level.
- Reducing the cost of installation.
- Compatible with single branch boxes and Multi-branch boxes.

Centrifugal VRF (4 to 10Hp)



The + points of the Hitachi solution

- No outdoor units visible on the façade of the building so ideal for listed buildings where planning permission is normally required.
- Connect up to 6 indoor units.
- Available pressure of 120Pa on the fan.
- Install in a suspended ceiling or technical room.
- Height < 600mm.
- Individual control of indoor units.
- Ideal for city-center high street businesses as no need to obtain permits to shut the road for a crane lift.
- Compatible with all ranges of HITACHI VRF indoor unit and DX KIT.

Smart oil management

Controls compressor oil level without sensors

Oil returns by suction:

the oil flows to the bottom of the casing, then rises by a difference in pressure between the HP and LP to the bearings and rollers.

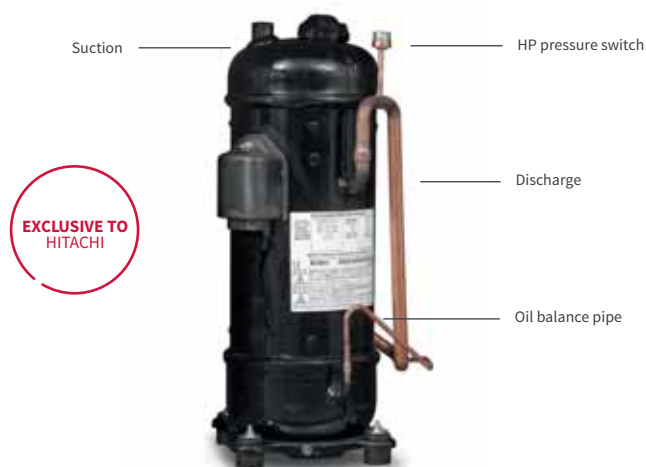

The + points of the Hitachi solution

Optimal lubrication

- Maintain the perfect oil level in the operating compressor, and in shutdown.
- Ensure the right oil level when restarting the compressor.
- Hitachi's high pressure scroll ensures oil naturally migrates from high pressure side to low pressure side lubricating the bearings.
- If any liquid returns to the compressor the high pressure, high temperature environment evaporates it ensuring the liquid doesn't damage the compressor.
- Reduce energy costs.
- Less wear and tear on the compressor.

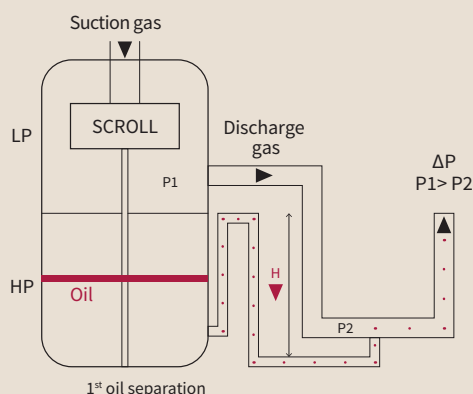

Smooth Drive control 2.0

Inverter frequency adjusted by 0.1 Hz for accuracy.

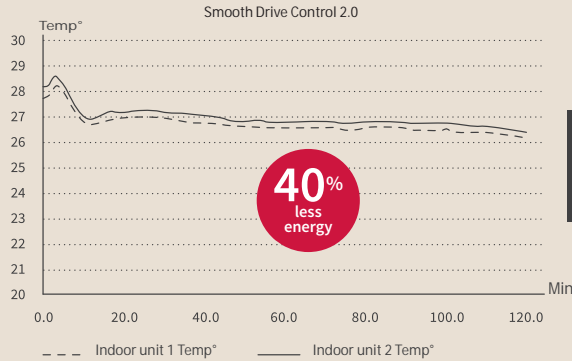
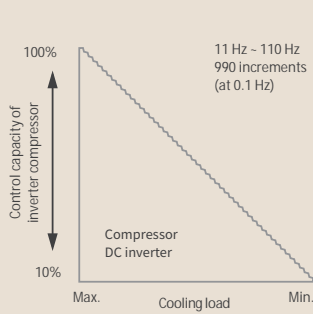

Performance at 25% partial load
 Cooling capacity = 7.88 kW
 Power input = 1.13kW
 EER = 6.96

The + points of the Hitachi solution

- Ambient temperature monitored in 0.1K increments compared to a 1K increment with Smooth Drive Control 1.0.
- Compressor power will ramp down to a minimum of 10% ensuring just 1 unit in a system can be operated.
- Improved partial-load performance: EER up to 6.96 (25% load).
- The setpoint temperature is quickly reached and maintained with frequent monitoring, at an accuracy of 0.1Hz.

Variable evaporating temperature

Smart Control automatically changes the evaporation temperature of the refrigerant according to the actual thermal requirements of the premises and the outside temperature.

The + points of the Hitachi solution

- Increased seasonal energy efficiency.
- High COPs and EERs at partial loads.
- Ultimate comfort.

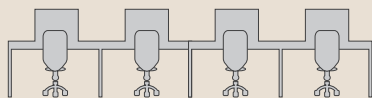
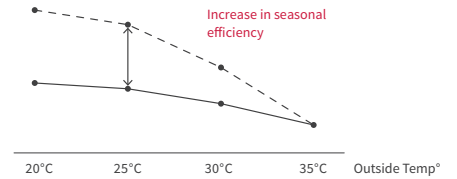
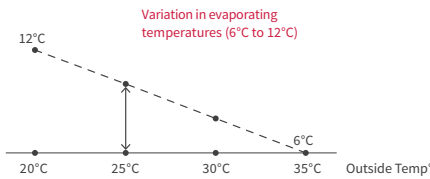
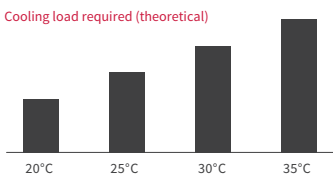

A meeting room in mid-season

High cooling needs: variable occupancy, computers, and sun.

- The evaporating temperature is decreased.
- The air off temperature = 8°C.
 - Cooling capacity - 100% load, with nominal energy consumption.



A separate office

Low cooling needs: stable occupancy.

- The evaporating temperature is increased.
- The air off temperature = 16°C.
 - Cooling capacity = 53% load, with 30% energy savings.

Smart defrost for continuous comfort

Smart defrost

- Continuous analysis of defrosting cycle durations and the system self-adapts to minimize them to between 3 to 9 min max.
- System optimized to detect the amount of ice on the outdoor unit's coils. (SIGMA, Set Free mini, Micro VRF and IVX Prime).

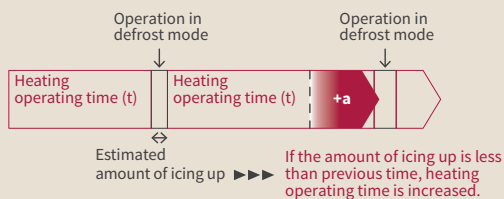

The + points of the Hitachi solution

- Runs for up to 4 hours without defrosting!
- Defrosting time limited to 3 to 9 min to maintain comfort.
- Indoor unit fans stop during defrost, then start again when air off T's > 30°C (user comfort maintained).
- Maintains the lower part of the external heat exchanger at temperatures between 5°C and 20°C.

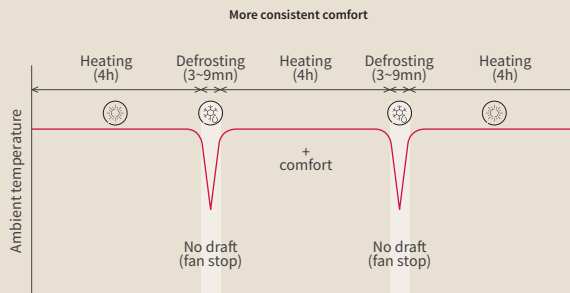

Defrost prevention

The system monitors the level of ice buildup in Heating mode. The refrigerant returning from the indoor unit defrosts the lower part of the outdoor unit heat exchanger. In Heating mode, the refrigerant returns to the outdoor unit at an average temperature of 5-20°C. This temperature is sufficient to carry out a preliminary defrost and by radiation it heats the upper part of the heat exchanger. Finally, the expansion valve of the outdoor unit decreases the pressure to complete the refrigeration cycle.

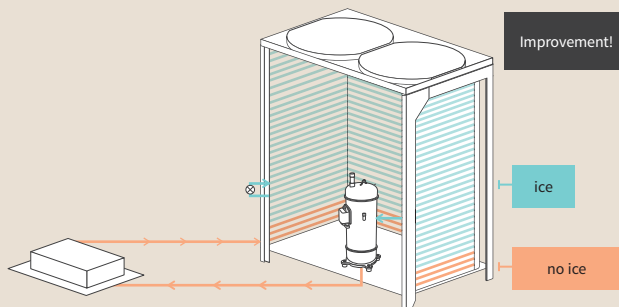

Enhanced protection from corrosion - 3 layers



3 coating layers

- 3 - Epoxy resin layer
- 2 - Waterproof film layer
- 1 - Lubricant layer
- Aluminum
- Lubricant layer
- Waterproof film layer
- Epoxy resin layer

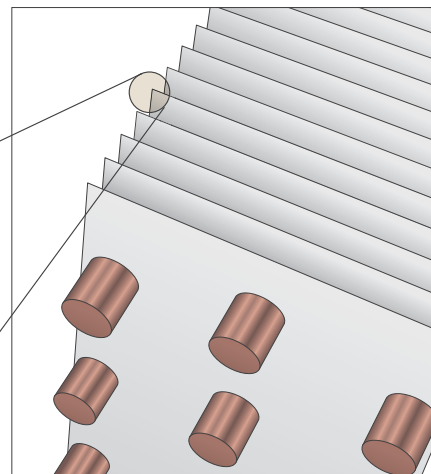
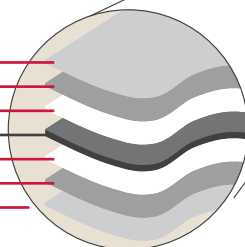

- Lubricant coating (1) protects against rust and limits corrosion.
- Hydrophilic coating (2) that prevents the concentration of water droplets and allows water to flow over the surface.
- Anti-corrosion coating (3) consisting of a chromium phosphate film or an epoxy resin to protect against corrosion.

The + points of the Hitachi solution

- Extending the life of the equipment.
- Maintaining energy performance over time.
- Protecting against aggressive environments: pollution in the city center, industrial sites, storage warehouses, salt spray.
- Units should still be installed more than **300 m from the ocean**, without specific Blygold treatment.
- Hitachi outdoor units (IVX, Set Free Mini, SIGMA) offer the best protection on the market.

Air off temperature control Gentle Cool

EXCLUSIVE TO
HITACHI

Potential for discomfort

GentleCool → No cold drafts

Ultimate
comfort



GentleCool: OFF



GentleCool: LOW



GentleCool: MEDIUM



GentleCool: HIGH



Min. Temp° control of the air off with the remote control PCARFP1E or the CSNET monitoring system

Rest of the market:

- Users feel cold drafts.
- Ducted units => Problems with condensation forming (poor quality of air).

The + points of the Hitachi solution:

- No more cold drafts
- Clean quality of air => No condensation in the ducts (ducted units), for improved quality of air inside.
- Available on all Hitachi indoor units.

FrostWash VRF SIGMA only

FrostWash's operating process is carried out in three stages: frosting, defrosting and cleaning the indoor unit's heat exchanger to remove built-up dirt and impurities. This improves air quality and maintains performance over time.



EXCLUSIVE TO
HITACHI

NEW

Available in 2022

The + points of the Hitachi solution

- Maintain the efficiency of the heat exchanger.
- Improve air quality by reducing the accumulation of dust and mold by up to 87%.
- Operation (<40 mins): Manual, Auto, and programmable.
- Only available on new outdoor units with Smooth Drive Control 2.0 (SIGMA).
- New remote control compatible with FrostWash function (PC-ARFG-E).

Compatible units:

- 800 x 800 cassette units: RCI-FSR
- 600 x 600 cassette units: RCIM-FSRE
- 2-way cassette units: RCD-FSR
- Ducted units: RPI(L/H)-FSRE
- Under ceiling unit: RPC-FSR

The biggest range of ducted units on the market (1.1kW to 56kW)

**DUCTED
THE MOST
COMPACT
ON THE MARKET!**
197 mm in height

Medium and high-pressure ducted unit

1.1 to 4kW: up to 100Pa
4 to 18 kW: up to 150Pa
11 to 18 kW: up to 200Pa

NEW



The + points of the Hitachi solution

- Extensive range of duties (1.1 to 18 kW in cooling).
- Low-height: 197 mm (RPIL-FSRE range: 100Pa).
- 30% fresh air intake.
- Refrigerant connections from the rear (RPIL model).
- “Gentle cool” regulated air off temperature setting to stop cold drafts and improve air quality.
- Easier filter removal (from below or from the side).
- Option to move the electrical box to other side of unit or to the wall (sizes 0.4 to 2Hp).
- Hitachi plenums available as an option.
- Compatible with Airzone plenums for zoning.
- Condensate pumps can be disconnected (RPIL)

High-pressure ducted unit

(220Pa) for high-power units “16 and 20Hp”

**EXCLUSIVE TO
HITACHI**



The + points of the Hitachi solution

- 30% fresh air intake.
- Highest capacity on the market at 56 kW in cooling mode.
- Highest air flow flow on the market under 220 Pa at 9,000 m³/h.
- 100% redundancy on RPI 16 and 20Hp with connection to two separate and independent units.
- Filtration as standard.
- Temperature control: average between return air sensors and remote control sensor.
- Suitable for large-scale applications: warehouses, supermarkets, etc.

SILENT ICONIC design panel for cassette units 800x800

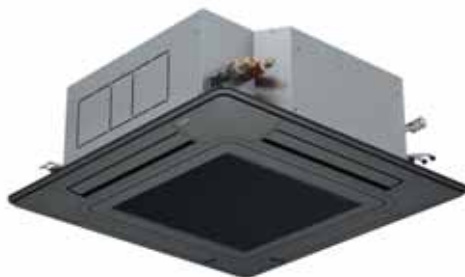

The + points of the Hitachi solution

- Sleak design that fits into the interior of any room.
- Design of the blades and shape of the louvers improve air distribution through the Coandă effect.
- Gentle Cool air off temperature setting for more comfort and energy savings.
- Compatible with R32 and R410A ranges (VRF and Utopia Prime air/air heat pump).
- Standard cassette version (white or black).
- Iconic Design cassette version (white or black).
- Installation in premises with high ceilings.

Size 0.4 Hp (1.1kW)

Available as a ducted unit



Available as a 600x600 cassette unit



Available as a wall unit



The + points of the Hitachi solution

- A response to new building standards with better insulated buildings.
- Heating and cooling capacity adapted to the thermal needs of small premises.
- More comfort: no overheating.
- Smaller units reduce the amount of refrigerant in the system which can eliminate the need for leak detection under EN378.
- Wall units, cassette units, ducted units have 4 speed settings.
- More air flow at the same capacity as competitor products: higher circulation rate.

Self-powered condensate pump (indoor units)

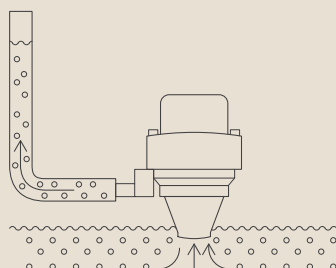

The + points of the Hitachi solution

- If the lift pump of one indoor units is faulty, the other units keep running.
- No impact on the facility as a whole.

Cooling accessories



Hitachi sanctions the use of pipework without brazing, LOKRING or others. However, the use of such technology for piping is the responsibility of the installer alone. And Hitachi cannot be held responsible for leakage problems.

Applicable pipe connections:

- Connections and reducers.
- Flare connections.
- Large radius elbows.
- Reduced elbows.

The use of original Hitachi Multikit components are mandatory.

Hitachi Multikit pipe kits



The + points of the Hitachi solution

- The shape of the multikit pipe kits promotes the flow of fluid compared to the widely used T-joint.
- **Energy performance guarantee.**
- Easier to install: the main line can be laid as a straight line.
- More space between the main line and the indoor unit line; makes it easier to use a pipe cutter to cut one of the pipes.

New remote control, hard wired design

PC-ARFG-E

Available from 2022



The + points of the Hitachi solution

- Elegant and modern design in a curved shape.
- Screen with parameters displayed in 5 different colours for ease of understanding.
- Functions: Cooling/heating mode, auto mode, dehumidification, fan speed, setpoint adjustment, weekly programming, show power consumption, Eco mode.
- More intuitive interface: easy access to menu functions, settings, FrostWash...
- Description of each function shown on the screen, no need to print out the manual.
- Special functions for hotel applications!
- Password-protected Service & Installation menu.

Solution for control and monitoring

NEW

Aircloud Pro



The + points of the Hitachi solution

- Connected central control solution via a server (Cloud) and web apps.
- Remote management functions and simple hourly programming, alarm notifications.
- Easy to maintain: alerts to show when the filter needs cleaning.
- Manage user accounts and multiple interfaces/sites for site managers.
- **More functions to be added over the year:** show energy consumption, compatibility with energy meter, 4G...
- IoT technology brings the power of the Cloud to your fingertips.

CSNET Manager 2 (version 2.0)



The + points of the Hitachi solution

- New features of version 2.0 of the CSNET software (managing the Yutaki, server room function, pulse meters on CSNET Lite, electricity and water metering for third-party systems...)
- Plug&Play management and monitoring solution.
- Modbus output available as standard.
- Air off temperature setting Gentle Cool.
- Local or remote management and monitoring.
- Alarm notifications by email.
- Visualization of the energy consumption.
- **No license required.**
- Large-scale systems: web version and touch tablet (CSNET Manager 2).
- Small systems: web version (CSNET Lite).

VRF outdoor units

Micro VRF (IVX Prime and IVX Comfort)



- New 4 to 6Hp range with R32 and R410A
- Available from 10 to 30 kW.
- Option to control up to 4 indoor units independently.
- Compact and lightweight units.
- Perfect for small application: residential and commercial.

VRF SET FREE Mini



EXCLUSIVE TO
HITACHI

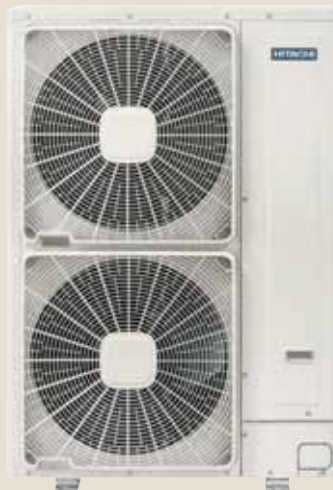

- 2-pipe: (4 to 12Hp)
- 3-pipe: (8 to 12Hp)
- Available from 12 to 33 kW.
- Available ESP: 30 Pa.
- Exclusive: large selection of compatible indoor units from 0.4 Hp.
- Connect up to 39 indoor units.
- Perfect for small, medium, and large-scale public applications.

VRF SET FREE Sigma



Sigma 2.5: available in 2022

- Available from 14 to 268 kW.
- 2-pipe / 3-pipe VRF solution available from the same universal outdoor unit.
- Standard range and high-efficiency range.
- Save space and money (single-module up to 67 kW).
- Exclusive comfort: GENTLE COOL function and smooth Drive Control.
- Available ESP: 80 Pa.
- Perfect for medium and large-scale commercial applications.

VRF IVX Centrifugal



EXCLUSIVE TO
HITACHI



- Available from 10 to 24 kW.
- Perfect solution for city center retail: invisible outdoor units, installed in suspended ceilings so ideal for listed buildings where permits would normally need to be obtained to shut the road for a crane lift.
- Option to individually control up to 6 indoor units.
- Perfect for small and medium projects in areas with restricted planning permission.

Benefits

Micro VRF (IVX Prime and IVX Comfort)

1 The smallest VRF on the market, in the most extensive range of its category.



Small businesses and offices have a variety of air-conditioning requirements and demand the best level of comfort. Available from 10 kW to 30 kW, the Micro VRF range meets the needs of any projects, no matter how much space is available.

2 External static pressure available on IVX for flexible installations

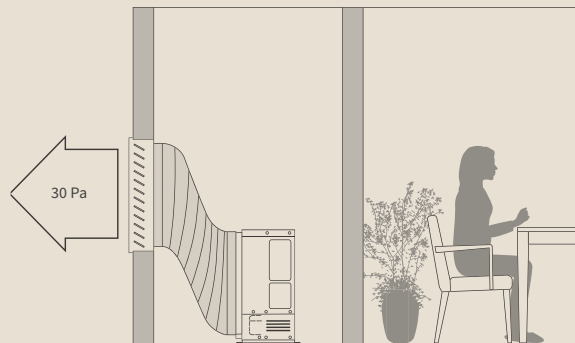

The new 4 to 6 Hp single-fan range features 30Pa of static pressure. A unit of 14kW (6 Hp), with a single fan, has a footprint of just 0.35 m². No static pressure available on IVX Comfort units (8 to 12Hp).

3 Independently control indoor units IVX Prime and IVX Comfort

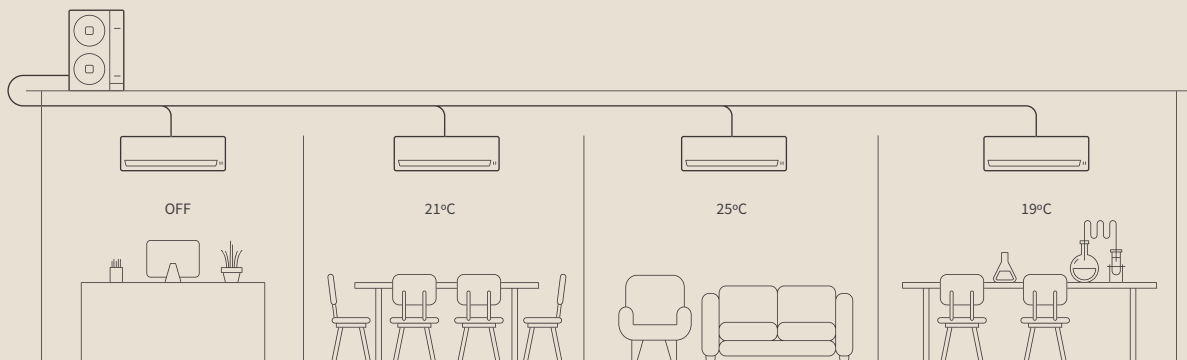

A comfortable indoor environment is achievable thanks to the ability to set different temperature set points. In many buildings, due to the orientation, the heating/cooling load may vary for each area. In such cases the option to individually set the temperature of each indoor unit is very useful.

Hitachi's Micro VRF range meets the comfort needs of every area, with individual temperature control. This solution is ideal for small and medium-sized commercial premises, with a single outdoor unit providing thermal comfort in 4 different rooms.

4

A wide choice of indoor units



In the same building, the requirements in terms of aesthetics, space, and temperature are different in each room. So it fits into any space, the Micro VRF range is compatible with all SYSTEM FREE indoor units: Wall, ducted, cassette, console and under ceiling units.

5

Less refrigerant piping,
more savings

The Micro VRF range is an interesting alternative to typical multi-split installations because it is easier to install. The refrigerant piping is in a single line with the same diameter throughout the main run. Multikits then branch off to the different indoor units, each with their own pipe sizes. This reduces the amount of refrigerant piping used and saves time as well as installation costs.

6

Even greater flexibility

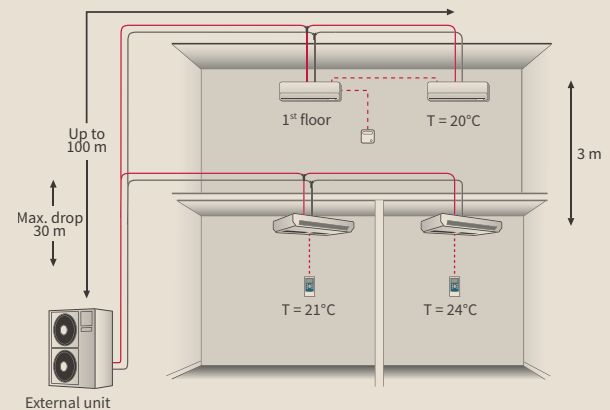

The Micro VRF units have a total pipe run of up to 100 m and a 30-m level difference between the indoor unit and the outdoor unit. This makes it much easier to place the outdoor unit in a suitable location, such as on the roof of the building, without interfering with the aesthetics of the premises.

It's also possible to install indoor units on different floors connected to the same pipe run. For example, a single outdoor unit can provide air-conditioning to a 2-floor commercial space.

Micro VRF (IVX Prime & IVX Comfort)



IVX Prime (R32 or R410A)

THE FIRST
HITACHI VRF
WITH R32
(4-6HP)



IVX Comfort (R410A)

Micro VRF with R32, the green choice

The R32 refrigerant has a number of advantages over the R410A refrigerant. Although both are “fluorinated greenhouse gases covered by the Kyoto Protocol,” the R32 has a lower global warming potential (GWP = 675) compared to the R410A (GWP = 2088). In addition, the use of R32 reduces the refrigerant charge by 7% to 12% compared to the equivalent installation on R410A. This **reduces its environmental impact by 75%** compared to R410: **low GWP and less load on the system**. This means it has a lower TeqCO2 equivalence, and a lower charge will still achieve better results because of its better thermodynamic characteristics. Another advantage of the R32 over the R410 is its greater ease of recovery and reuse, taking into account the fact that the installation and maintenance are very similar.

Flexible installation

The new 4 to 6Hp range with R32 and R410A has an external static pressure of 30Pa. This allows the condenser to be installed inside and ducted to outside. Connect up to 4 indoor units in the Set free range (size 0.8Hp units compatible).

Large operating ranges

The Micro VRF will keep performing in extreme temperatures: down to -20°C in heating and -15°C to 46°C in cooling (-5°C to 46°C for 4 to 6Hp). Features that make this a product perfect for year-round comfort.

Advanced anti-corrosion treatment

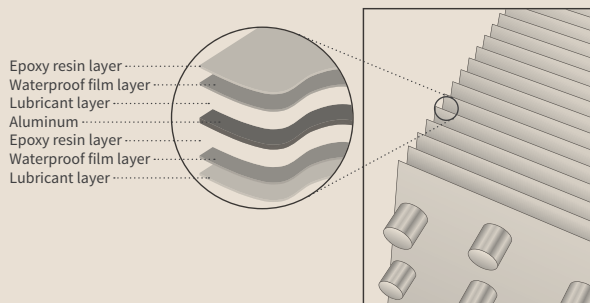

Customizable personal comfort

The air off temperature on each indoor unit can be independently set according to requirements. Customize your comfort with the GENTLE COOL setting on the latest wired remote controls. In summer, cold drafts can be avoided as you can set the air off temperature to the maximum setting.

Outdoor units

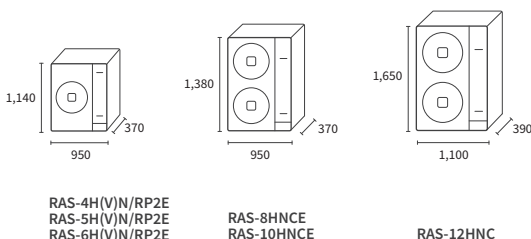

Performance, cooling	Unit	Version R32 (4 ~ 6Hp)			Version R410A (4 ~ 6Hp)		
		RAS-4H(V)RP2E	RAS-5H(V)RP2E	RAS-6H(V)RP2E	RAS-4H(V)NP2E	RAS-5H(V)NP2E	RAS-6H(V)NP2E
Nominal cooling capacity (min-max)	kW	10.00 (4.50 - 11.20)	12.50 (5.70 - 14.00)	14.00 (6.00 - 16.00)	10.00 (4.50 - 11.20)	12.50 (5.70 - 14.00)	14.00 (6.00 - 16.00)
Rated power input cooling	kW	2.51	3.42	4.32	2.81	3.83	4.91
EER	-	3.98	3.66	3.24	3.56	3.26	2.85
SEER (average climate) ⁽²⁾	-	7.31(V) - 6.96	8.35(V) - 8.20	7.35(V) - 7.25	7.04(V) - 6.72	7.80(V) - 7.67	7.01(V) - 6.92
Seasonal energy class (cooling)	-	A++	-	-	A++	-	-
Working range in Cooling ⁽¹⁾	-	-5°C / 46°C (DB)			-5°C / 46°C (DB)		
Performance, heating							
Nominal heating capacity (min-max)	kW	11.20 (5.00 - 14.00)	14.00 (5.00 - 18.00)	16.00 (5.00 - 20.00)	11.20 (5.00 - 14.00)	14.00 (5.00 - 18.00)	16.00 (5.00 - 20.00)
Rated power input heating	kW	2.60	3.39	3.64	2.56	3.39	3.64
COP	-	4.31	4.13	4.40	4.38	4.13	4.40
SCOP (average climate) ⁽²⁾	-	4.60	4.75	4.73	4.64	4.68	4.71
Seasonal energy class (heating)	-	A++	-	-	A++	-	-
Working range in heating	-	-20°C / 18°C (WB)			-20°C / 18°C (WB)		
Technical features							
Airflow (cooling)	m ³ /h	4800	4800	4800	4800	4800	4800
Sound pressure in Cooling (night mode)	dB(A)	54 (51)	56 (51)	56 (51)	54 (51)	56 (51)	56 (51)
Sound power	dB(A)	70	72	72	70	72	72
Net weight	kg	86 (84)			86 (84)		
Dimensions (H x L x D)	mm	1140 x 950 x 370			1140 x 950 x 370		
Min. power of indoor unit	Hp	0.8			0.8		
Number of units that can be connected (min - max)	-	1 - 4 ^(v*)			1 - 4 ^(v*)		
Available static pressure	Pa	30			30		
Connectable index (min.-max.)	%	90% - 115%			90% - 115%		
Compressor	-	Inverter DC rotary unit			Inverter DC rotary unit		
Refrigeration characteristics							
Max. length / additional charge	m/g/m	75 / 45			75 / 60		
Initial refrigerant charge	kg	3.0			3.2		
Pre-charged for	m	30			30		
Min. length	m	5			5		
Max. level difference (outdoor unit above / below)	m	30 / 20			30 / 20		
Diameter of pipes (Liq / Gas)	inches	3/8 - 5/8			3/8 - 5/8		
Refrigerant	-	R32			R410A		
Electrical features, outdoor unit							
Power supply	-	3N~ 400V 50Hz (1~ 230V 50Hz)			3N~ 400V 50Hz (1~ 230V 50Hz)		
Max. current	A	15.0 (22.5)			15.0 (22.5)		
Recommended fuse size	A	20.0 (25.0)			20.0 (25.0)		
Cable width (EN 60 335-1) ⁽⁴⁾	mm ²	5 x 4.00 (3 x 6.00)			5 x 4.00 (3 x 6.00)		
Indoor/outdoor connection (shielded) ^(2*)	mm ²	2 x 0.75			2 x 0.75		

⁽¹⁾ It is the installer's responsibility to ensure that these cable widths meet the needs of the facility and applicable standards.

⁽²⁾ Performance values are stated for RCI-FSR cassette units in accordance with Eurovent benchmarks.

^(v*) Single-phase version

controls and compatible accessories (see the tab VRF TWIN controls)

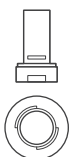

Condensation drainage kit
 DDB-26 (models IXV Prime and IXV Comfort
 4 / 5 / 6 / 8 / 10 / 12 Hp)
 DDB-12L (Comfort models 2 / 2.5 / 3 Hp)



Multi kit

Performance, cooling	Unit	RAS-8HNC	RAS-10HNC	RAS-12HNC
Nominal Cooling capacity (min-max)	kW	20.00 (8.00 - 22.40)	25.00 (10.00 - 28.00)	30.00 (11.20 - 33.50)
Rated power input in Cooling mode ⁽⁵⁷⁾	kW	5.95	8.28	11.67
EER	-	3.36	3.02	2.57
SEER (average climate) ⁽³⁾	-	6.79	6.61	5.30
Seasonal energy class	-	-		
Working range in cooling	-	(OPT -15°C)* -5°C / 46°C (DB)		
Performance, heating				
Nominal Heating capacity (min-max)	kW	22.40 (6.30 - 28.00)	28.00 (8.00 - 35.00)	33.50 (9.00 - 37.50)
Rated power input heating	kW	5.88	7.71	9.46
COP	-	3.81	3.63	3.54
SCOP (average climate) ⁽³⁾	-	4.19	3.79	3.66
Seasonal energy class	-	-		
Working range in heating	-	-20°C / 15°C (WB)		
Technical features				
Airflow (cooling)	m ³ /h	7620	8040	9780
Sound pressure in Cooling (night mode)	dB(A)	57 (55)	58 (56)	59 (56)
Sound power	dB(A)	76		77
Net weight	kg	136	138	168
Dimensions (H x L x D)	mm	1380 x 950 x 370		1650 x 1100 x 390
Min. power of indoor unit	Hp	1.8		
Number of units that can be connected (min - max)	-	1 - 4		
Connectable index (min.-max.)	-	See following page		
Compressor	-	SCROLL Inverter		
Refrigeration characteristics				
Max. length / additional charge	m/g/m	100 / to be calculated according to technical documentation		
Initial refrigerant charge	kg	5.7	6.2	6.7
Pre-charged for	m	30		
Max. level difference (outdoor unit above / below)	m	30 / 20		
Diameter of pipes (Liq / Gas)	inches	3/8 - 1 1/8 ⁽⁴⁾	1/2 - 1 1/8	
Refrigerant	-	R410A		
Electrical features, outdoor unit				
Power supply	-	3N ~ 400V 50Hz		
Max. current	A	24		
Recommended fuse size	A	32		
Cable width (EN 60 335-1) ⁽⁴⁷⁾	mm ²	5 x 6.00		
Indoor/outdoor connection (shielded) ⁽²⁷⁾	mm ²	2 x 0.75		

* To ensure cooling mode at -15°C, use the "cooling only" and "master/slave" switch settings.

⁽¹⁾ If longer than 70 m, halve the diameter of the liquid pipe.

⁽²⁾ Shielding must be renewed every 300 m.

⁽³⁾ Performance values are stated for RCI-FSN4 cassette units in accordance with Eurovent benchmarks.

⁽⁴⁾ Data shown is for indication purposes only. It is the installer's responsibility to ensure that these cable widths meet the needs of the facility and current standards.

(V) Single-phase version.

controls and compatible accessories (see the tab VRF TWIN controls)



Condensation drainage kit

DDB-26 (IVX Comfort models 4 / 5 / 6 / 8 / 10 / 12 Hp) DDB-12L (Comfort models 2 / 2.5 / 3 Hp)



Multi kit

Installation rules

Micro VRF (IVX Prime and IVX Comfort)

Quantity of indoor units

Outdoor unit (Hp)	4	5	6	8	10	12
Max. number of indoor units		4*			4	
Min. power of indoor unit		0.8			1.8	

Permitted connection rate

External unit	Hp	4	5	6	8	10	12
Max. number of indoor units	1	90~115%			90~115%		
	2	3.6 to 4.6 Hp	4.5 to 5.75 Hp	5.4 to 6.9 Hp			
	3 or 4	3.6 to 4 Hp	4.5 to 5 Hp	5.4 to 6 Hp	7.2 to 9.2 Hp	9 to 11.5 Hp	10.8 to 13.8 Hp

Units 4 to 12 Hp: permitted installation (1 to 4 indoor units)

Installation with multikits. 1 main line. Constant diameter.

Multikit

External unit	Hp	4	5	6	8	10	12
Max. length between outdoor unit and the furthest indoor unit	Actual length	m	75	75		100	
	Equivalent length	m	95	95		125	
Max. level difference outdoor unit to indoor unit (H) (outdoor unit above/below)	m				30/20		
Max. level difference from indoor unit to indoor unit	m				3		
Max. level difference from Multikit to indoor unit / Multikit to Multikit	m				3		
Total length of the pipe	m		85 (with 2, 3, or 4 indoor units)	85 (with 2, 3, or 4 indoor units)	100		145
Max. length of indoor unit to Multikit	m			10			15
Max. length of first Multikit to indoor unit	m			15			25
Length of main branch A	m			A > B, C, D, E, F, G			
Max. imbalance between branches	B-C	m		< 10m			

Multikit part numbers	Hp	E-102SN4	E-162SN4
Diameter of the main line		Constant diameter	
Diameter of outdoor unit - first multikit	Liq/Gas	-	3/8 - 5/8
			3/8** - 1 1/8
			1/2 - 1 1/8

Power of indoor unit	Hp	< 1.5	1.8 to 2	2.3 to 6
Diameter of the indoor unit multikit		-	1/4 - 1/2	1/4 - 5/8
				3/8 - 5/8

Note: It is not possible to connect 8 Hp or 10 Hp indoor units.

* Caution: When connecting RCI cassette units, the max. number is limited to two on 6 Hp model. **If the pipe is longer than 70m, use a 1/2" liquid line instead of 3/8".

Benefits

VRF SET FREE Mini

1 Choice of 2-pipe / 3-pipe (8 to 12 Hp)



EXCLUSIVE TO
HITACHI

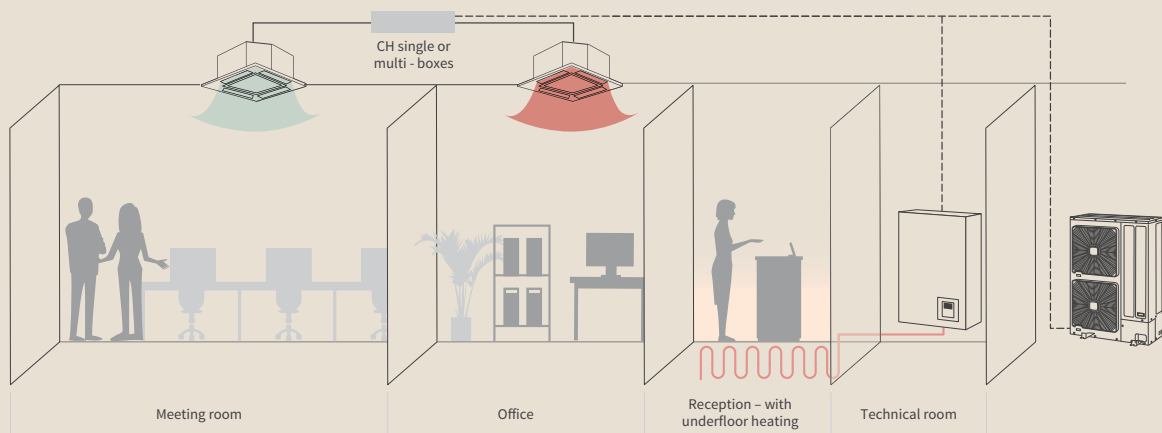

Hitachi has redefined mini VRF with its sideflow heat recovery system offering unparalleled comfort and flexibility. The new SET FREE Mini range from 8 to 12 Hp is exclusively compatible with a 2-pipe or 3-pipe installation and both from the same universal outdoor.

The SET FREE Mini is perfect when the outdoor space is limited but simultaneous heating and cooling is still required.

2 The most compact 3-pipe mini VRF in the world

-37%
FOOTPRINT

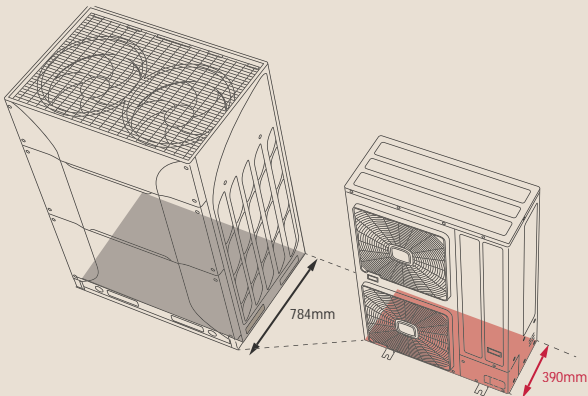

With its greatly reduced footprint, the SET FREE Mini can be installed discreetly for maximum discretion.

3 High number of indoor units that can be connected

Outdoor unit (Hp)	Number of indoor units that can be connected
4	13
5	16
6	18
8	26
10	32
12	39

The new SET FREE Mini can connect up to 39 indoor units!
Exclusive: even more flexibility with a wide choice of units from 0.4Hp.

4 External static pressure available

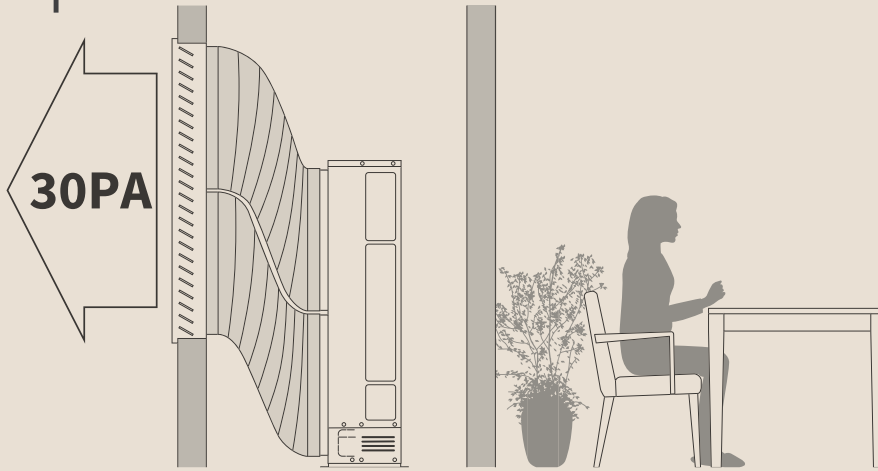

Thanks to the external static pressure now available, our SET FREE Mini units can be installed inside a plant room while preserving the aesthetics of your buildings.

5 Compatible with all Set free indoor units with the Gentle Cool air off setting for more comfort



The GENTLE COOL air off temperature setting, accessible on the wired remote control PC-ARFP1E, adjusts the minimum blown air off temperature for your comfort. In summer, cold drafts are avoided as you can set the air off temperature to the maximum setting.



VRF SET FREE Mini

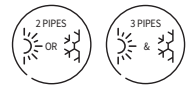

Advanced anti-corrosion treatment

With its triple coating, the SET FREE MINI offers the best protection on the market for use in tough environments.

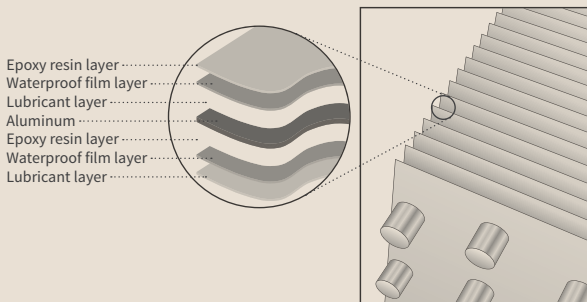

Precise temperature control is maintained with Smooth Drive Control

Ultra-precise compressor frequency control (0.1Hz) ensures optimum outdoor unit performance under partial loads and a consistent indoor temperature. This new feature allows a single 1.1kW (0.4Hp) unit to operate on its own if required.

Smart Defrost

The smart defrost feature ensures a longer heating period without defrosting. This period automatically adjusts to the defrosting time of previous cycles and can extend up to 240 minutes, improving the comfort level as well as the heating capacity.

Easier maintenance

Direct access to the 7-segment display to perform tests and diagnostics. Real-time operating conditions and installation error codes are displayed for ease of servicing.

Large operating range

Outside temperature operating range

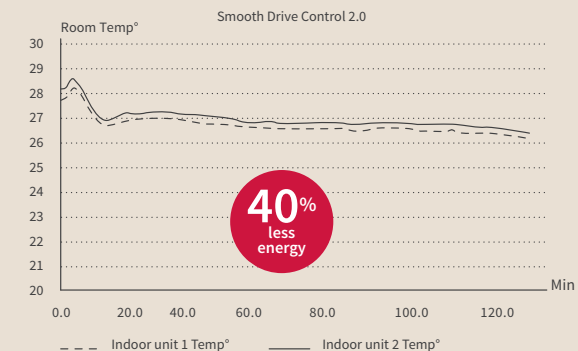
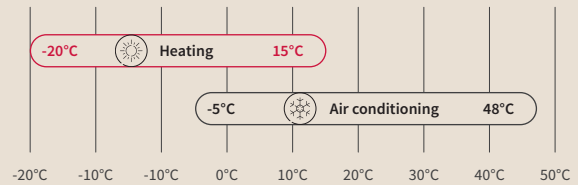

Performance at 25% partial load
Cooling capacity = 7.88 kW
Power Input = 1.13kW
EER = 6.96

Outdoor units

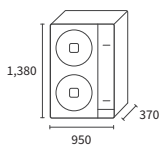

SET FREE Mini S
RAS-4FS(V)NME
RAS-5FS(V)NME
RAS-6FS(V)NME

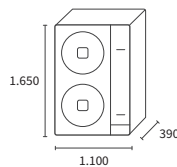

SET FREE Mini L
RAS-8FSXNME
RAS-10FSXNME
RAS-12FSXNME

Performance, cooling	Unit	RAS-4FS(V)NME	RAS-5FS(V)NME	RAS-6FS(V)NME	RAS-8FSXNME	RAS-10FSXNME	RAS-12FSXNME
Nominal Cooling capacity	kW	12.10	14.00	16.00	22.40	28.00	33.50
Rated power input cooling	kW	2.97	3.26	4.35	6.25	7.27	9.36
EER	-	4.07	4.29	3.68	3.60	3.85	3.58
SEER Three-phase / Single-phase	-	6.61 / 6.67	6.61 / 6.64	6.37 / 6.40	7.59	8.31	8.26
Working range in Cooling	-	-5°C / 48°C (DB)					

Performance, heating	Unit	RAS-4FS(V)NME	RAS-5FS(V)NME	RAS-6FS(V)NME	RAS-8FSXNME	RAS-10FSXNME	RAS-12FSXNME
Nominal Heating capacity	kW	12.50	16.00	18.00	25.00	31.50	37.50
Rated power input heating	kW	2.89	3.57	4.30	5.32	6.89	9.15
Heating capacity at -7°C	kW	8.6	10.8	12.0	18.6	21.5	25.5
Heating capacity at -15°C	kW	7.3	8.7	10.0	16.2	17.7	21.1
COP	-	4.33	4.48	4.19	4.70	4.57	4.10
SCOP	-	4.15	4.40	4.25	5.62	4.72	4.66
Working range in heating	-	-20°C / 15°C (WB)					

Technical features							
Airflow	m³/h	8,700			9,900	11,100	
Available static pressure	Pa	30					
Number of fans	-	2					
Sound power in Cooling mode	dB(A)	69	72	74	76	77	
Sound pressure in Cooling mode	dB(A)	52		53	55	59	60
Dimensions (H x L x D)	mm	1380 x 950 x 370			1650 x 1100 x 390		
Net weight of single-phase / three-phase	kg	114 / 115	118 / 119		- / 188	- / 194	- / 196
Type of compressor	-	Scroll Inverter					
Compressor number	-	1					
Max. number of connectible units	-	13	16	18	26	32	39
Connection ratio (min - max)	%	50-130					

Refrigeration characteristics								
Refrigerant	-	R410A						
Refrigerant charge	kg	3.7	4.1	4.1	4.2	5.5		
Diameter of pipes	Liquid	inches	3/8				1/2	
	Low pressure gas	inches	-			3/4	7/8	1 1/8
	High pressure gas	inches	5/8		5/8	3/4	7/8	

Electrical features							
Power supply	Three-phase (Single-phase)	-	3N ~400V 50 Hz (1 ~230V 50 Hz)			3N ~400V 50 Hz	
Max. current	Three-phase (Single-phase)	A	16 (23.5)		18	19	23
Recommended fuse size		A	20 (25)		20		25
Indoor/outdoor connection (shielded)	mm	2 x 0.75					

controls and compatible accessories (see the tab VRF TWIN controls)

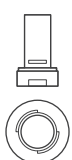

Condensate drain kit
DBS-26



Multi kit

Piping rules

VRF SET FREE Mini

Installation flexibility

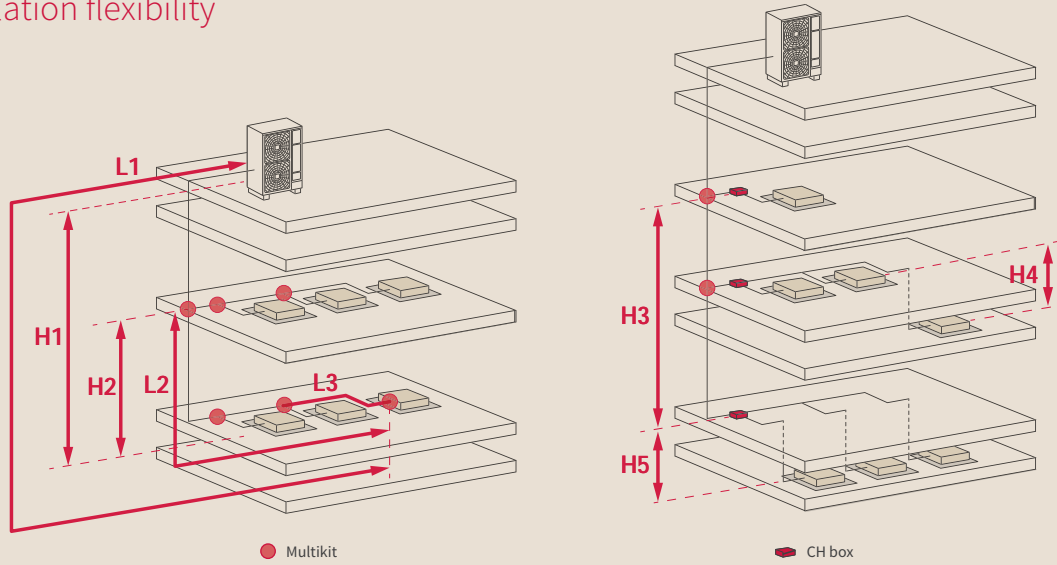

			4 to 6 Hp	8 to 12 Hp	8 to 12 Hp (heat recovery)	
Max. length of piping	Total	-	180	500	500	
	Between outdoor unit and the furthest indoor unit	L1	85	125	125	
	Between the first multikit branch and the furthest indoor unit	L2	40	90*	90*	
	Between the multikit and the indoor unit	L3	15	40	40	
	Between the CH box and the indoor unit	-	-	-	40	
Max. level difference	Between the outdoor unit and the indoor unit	Outdoor unit above the indoor unit	H1	30	50	50
		Indoor unit above the outdoor unit	-	30	40	40
	Between indoor units	H2	15	15	15	
	Between CH boxes	H3	-	-	15	
	Between indoor units connected to a CH box (same branch)	H4	-	-	4	
	Between the CH box and the indoor unit	H5	-	-	15	

(*) 40 m over the recommended number of indoor units.

Part numbers of piping accessories

Multikit



2P

3P

E-102SN4

E-102XN3

E-162SN4

E-162XN3

Header



2P

3P

MH-84AN1

MH-108XN

MH-108AN

-

Benefits

VRF SET FREE Sigma

1 Smart Defrost for uninterrupted comfort

Smart defrost optimizes the defrosting cycle and stops the indoor unit fans during the defrost to ensure there are no cold drafts.

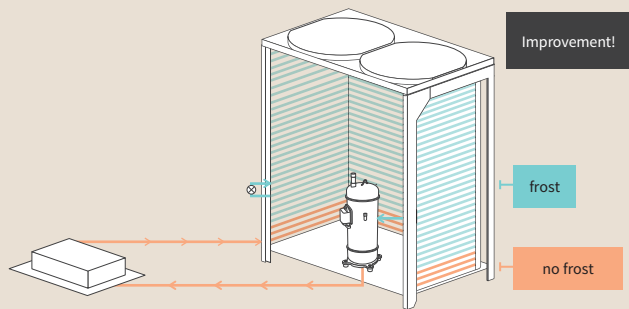
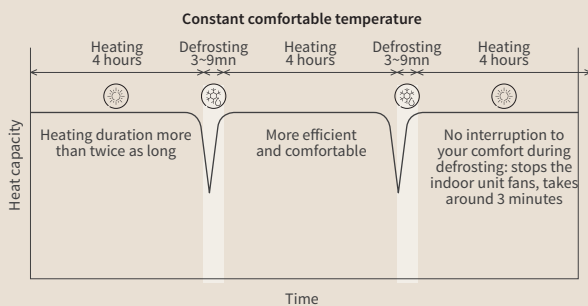

SIGMA's new smart defrost mode provides a defrost-free heating period that is twice as long as the previous model. This period automatically adjusts to the defrosting time of previous cycles and can extend up to 240 minutes. The system also monitors the level of ice buildup when in Heating mode. A hot gas bypass continuously defrosts the underside of the outdoor unit heat exchanger to ensure that when units go into defrost they complete the process within 3 minutes.

2 Smooth drive control

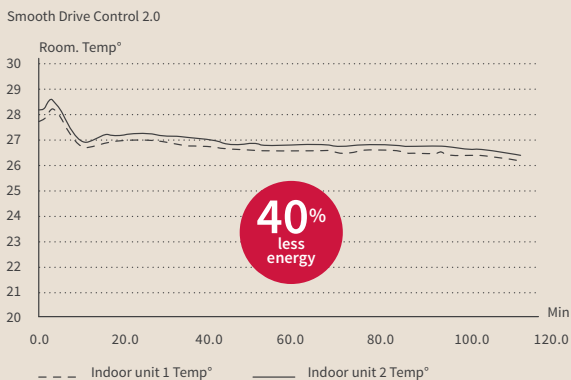

Performance at 25% partial charge

Cooling capacity = 7.88 kW
Power input = 1.13kW
EER = 6.96

Ultra-precise compressor operation system adjusts the capacity in steps of 0.1Hz. This ensures the best outdoor unit performance under partial loads and a consistent indoor temperature. This new feature can, among other things, individually run just one 0.4 Hp (1.1 kW) unit.

3 Variable evaporation temperature

Smart Control automatically changes the evaporation temperature according to the actual heating requirements of the premises and the outside temperature, for fantastic energy savings.

4 Very low noise level

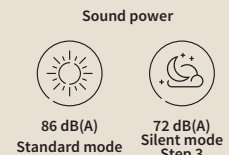

	18 Hp	42 Hp
Silent mode	Sound power	Sound power
Standard	86	90
Step 1	82.5	86
Step 2	77.5	81
Step 3	72.5	76

So it fits perfectly into any type of environment, the SET FREE SIGMA comes with Silent mode as standard. This makes it the quietest VRF on the market.

5 Versatile

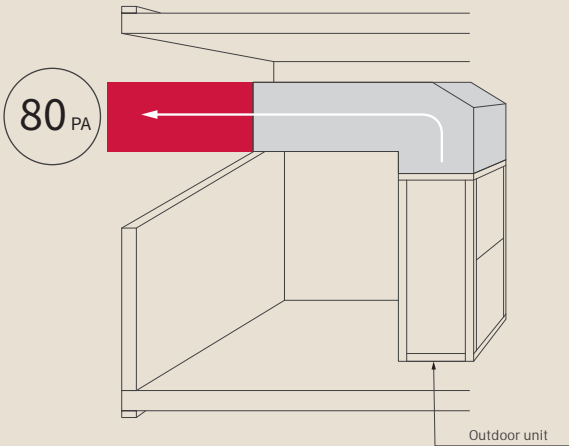

Thanks to 3 static pressure settings: 30 Pa, 60 Pa, 80 Pa, the SET FREE SIGMA can be installed both outside and inside a plant room to meet the needs of even the most complex setups.

6 Energy saving

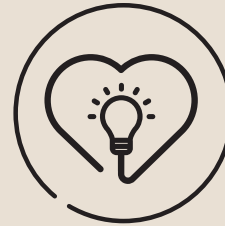

With ambitious climate change policies aiming to reduce emissions to net zero by 2050 reducing the energy consumption of buildings will be essential. The SET FREE SIGMA was designed to accompany this green commitment with its very high energy performance and its 0.4Hp (1.1kW) indoor units.

7 Heat recovery systems that are easy to install

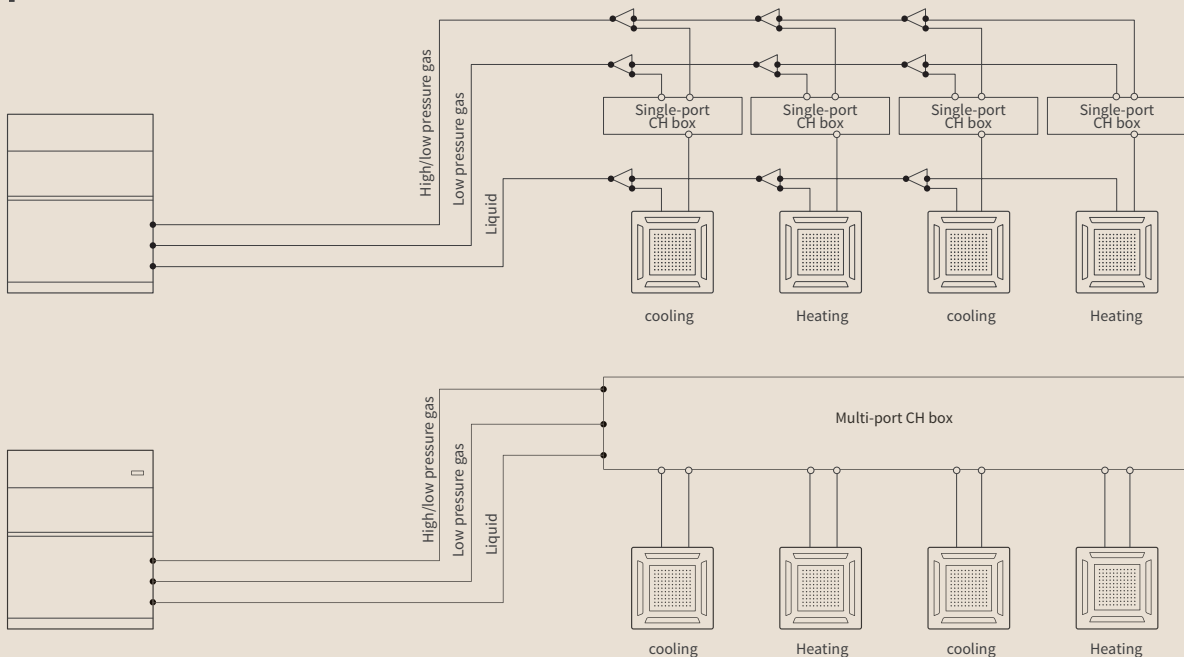

A wide range of CH boxes are available in both single and multi versions with up to 16 ports for maximum flexibility; the lightest and most compact on the market. These boxes do not require a drain connection, making the installer's work much easier. Always with user comfort in mind, these boxes are also very quiet.

VRF SET FREE SIGMA with heat recovery

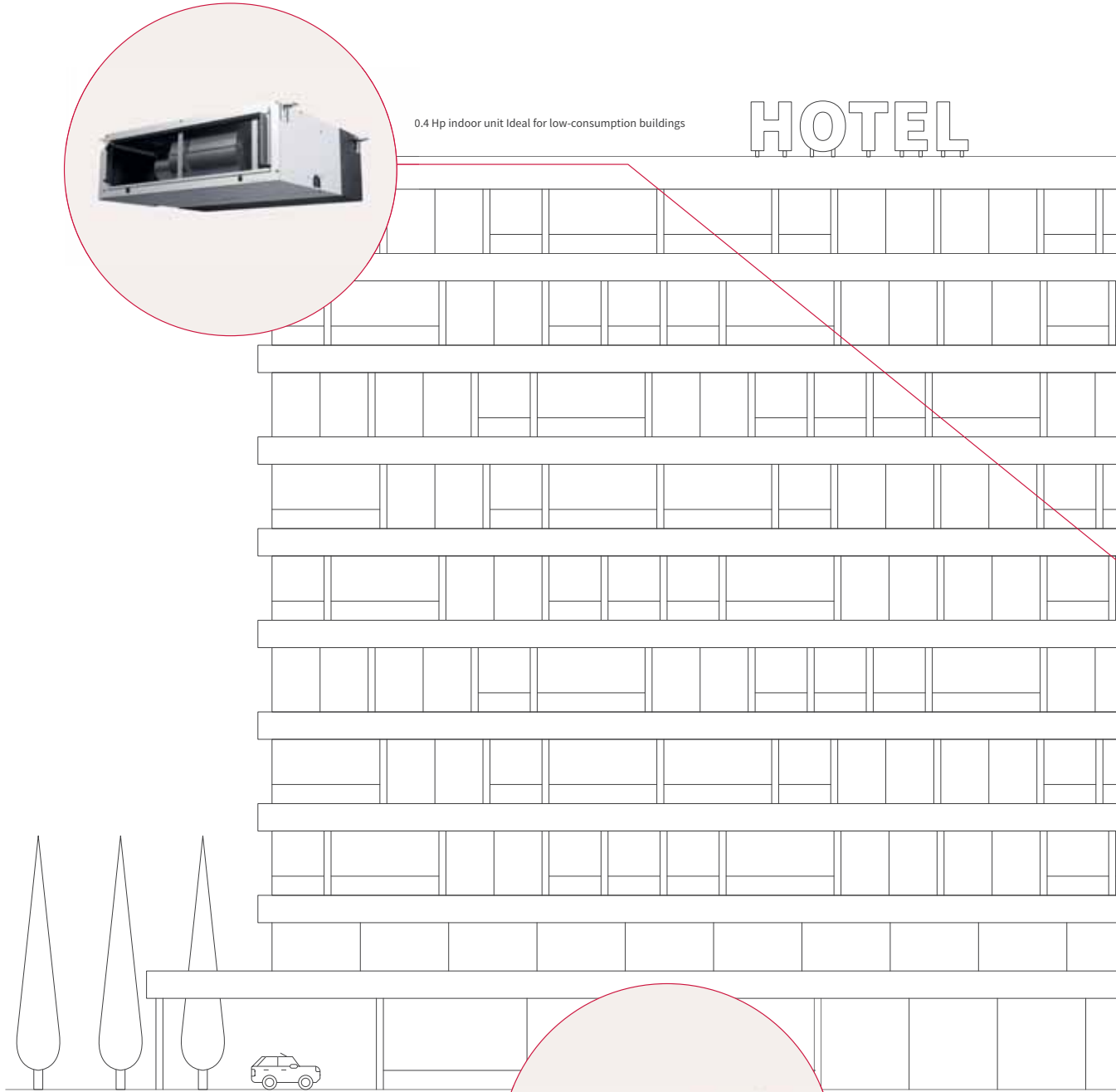

HOTEL



0.4 Hp indoor unit Ideal for low-consumption buildings

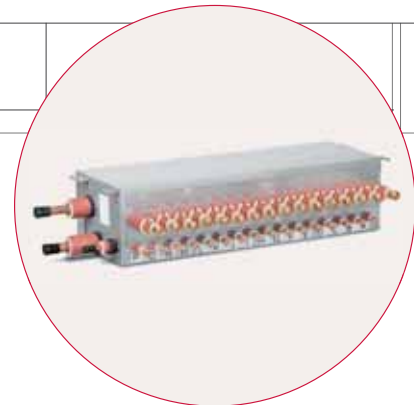

CH box with 16 ports

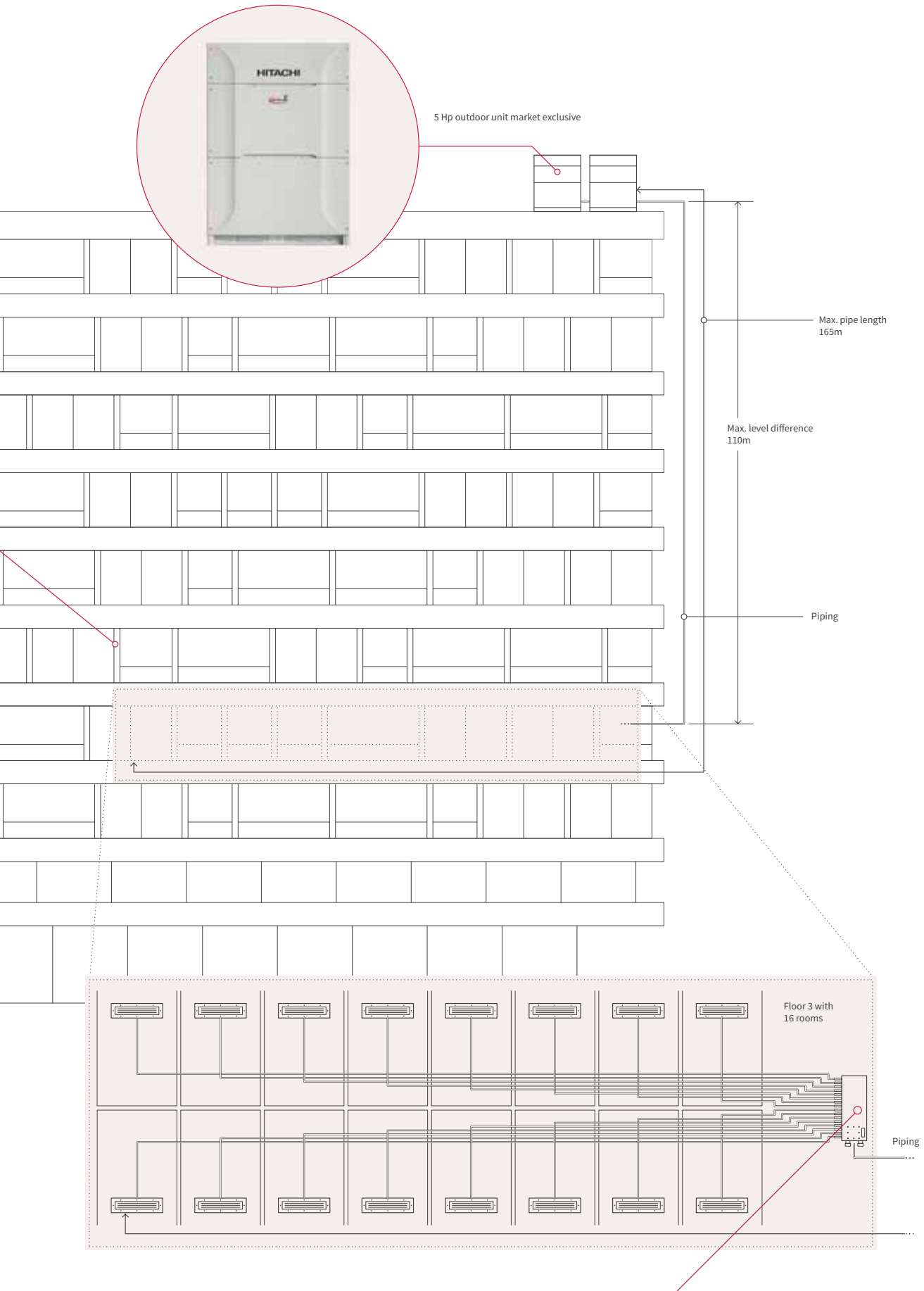

VRF SET FREE Sigma Standard



The widest single-module range on the market

Compact and lightweight the SET FREE SIGMA Standard Hitachi range is exclusively available in single modules from 8 Hp to 24 Hp models.

Exclusive solution

3-pipe / 2-pipe universal outdoor unit meets the needs of both energy recovery applications and reversible heat pump ones from the same outdoor, allowing for sites to be retrofitted from heat pump to heat recovery or vice versa without having to change the outdoor.

Advanced anti-corrosion treatment

With its triple coating, SIGMA VRF offers the best protection on the market for use in tough environments.

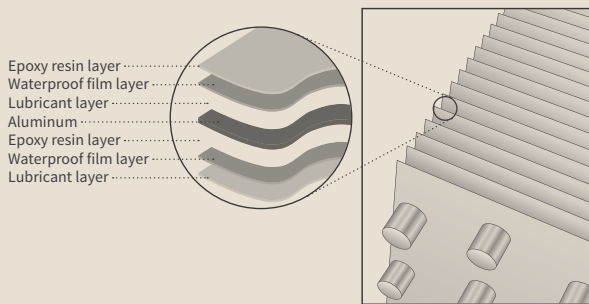

Large operating ranges

Outside temperature operating range

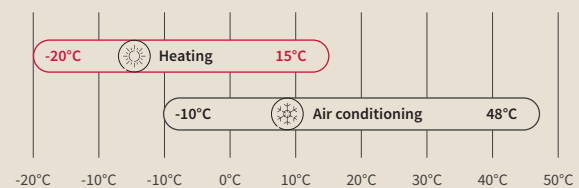

Variable evaporation temperature

The control logic built into SIGMA VRF units saves more energy and increases user comfort the whole year round. If the thermal requirements of the internal rooms are low then the system will automatically select a high evaporating temperature which will increase seasonal efficiency and reduce cold drafts. If the thermal needs of indoor rooms change, like a meeting room is needed with a high occupancy level, the system will automatically detect this and decrease the evaporating temperature. This will ensure the cooling load of the room can be met quickly and occupants remain comfortable. This smart refrigerant control is complemented by the GENTLE COOL setting, in which users set the minimum air off temperature per fan coil to avoid cold drafts at all times, SIGMA is now the most comfortable VRF on the market.

Backup function

An outdoor unit can be isolated for maintenance while other units continue to operate.

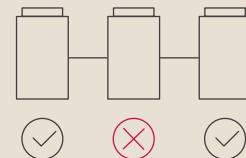

Outdoor units

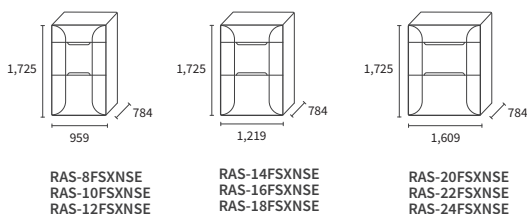

Performance, cooling	Unit	RAS-8FSXNSE	RAS-10FSXNSE	RAS-12FSXNSE	RAS-14FSXNSE	RAS-16FSXNSE	RAS-18FSXNSE	RAS-20FSXNSE	RAS-22FSXNSE	RAS-24FSXNSE
Nominal Cooling capacity	kW	22.4	28	33.5	40	45	50	56	61.5	67
Rated power input Cooling	kW	5.40	7.27	8.89	12.12	13.85	14.9	18.6	20.4	22.4
EER	-	4.15	3.85	3.77	3.30	3.25	3.35	3.01	3.01	2.99
SEER	-	7.50	7.17	6.97	7.47	7.30	6.96	6.29	6.76	6.20
Working range in Cooling	-	-10°C / 48°C DB								

Performance, heating	Unit	RAS-8FSXNSE	RAS-10FSXNSE	RAS-12FSXNSE	RAS-14FSXNSE	RAS-16FSXNSE	RAS-18FSXNSE	RAS-20FSXNSE	RAS-22FSXNSE	RAS-24FSXNSE
Nominal Heating capacity	kW	25	31.5	37.5	45	50	56	63	69	77.5
Rated power input Heating	kW	5.26	6.89	9.15	12.03	15	17	19	22	23
Power at -7°C ⁽¹⁾	kW	19.92	25.1	26.46	33.08	35.57	39.73	44.70	48.95	51.7
Power at -15°C (or -20°C) ⁽¹⁾	kW	15.8	19.8	20.3	25.5	27	30.20	34	37.30	39.5
COP	-	4.75	4.57	4.10	3.74	3.37	3.29	3.35	3.19	3.4
SCOP	-	4.17	4.11	4.29	4.48	4.42	4.18	4.14	4.43	4.43
Working range in Heating	-	-20°C / 15°C WB								

Technical features	Unit	RAS-8FSXNSE	RAS-10FSXNSE	RAS-12FSXNSE	RAS-14FSXNSE	RAS-16FSXNSE	RAS-18FSXNSE	RAS-20FSXNSE	RAS-22FSXNSE	RAS-24FSXNSE
Airflow	m ³ /h	9900	10200	11400	14340	15360	15360	19740	19740	20880
Adjustable static pressure	Pa	30 / 60 / 80								
Number of fans	-	1				2				
Sound power	dB(A)	80	82	82	85	85	86	86	84	86
Sound pressure ⁽²⁾ (Night mode)	dB(A)	58 (53)	60 (53)	59 (54)	63 (57)	63 (57)	65 (57)	65 (59)	64 (59)	66 (59)
Dimensions (H x L x D)	mm	1725 x 959 x 784			1725 x 1219 x 784			1725 x 1609 x 784		
Net weight	kg	210		233	287	329	330	382	398	399
Type of compressor	-	DC Scroll Inverter								
Compressor number	-	1				2				
Max. number of indoor units that can be connected	-	26	32	39	45	52	58	64		
Connection ratio (min - max) ⁽³⁾	-	50 - 130%								

Refrigeration characteristics	Unit	RAS-8FSXNSE	RAS-10FSXNSE	RAS-12FSXNSE	RAS-14FSXNSE	RAS-16FSXNSE	RAS-18FSXNSE	RAS-20FSXNSE	RAS-22FSXNSE	RAS-24FSXNSE
Refrigerant	-	R410A								
Refrigerant charge	kg	5		7.20	8.90	9.90	10.70	11.30	11.30	11.6
Diameter of pipes	Liquid	3/8		1/2		1/2	5/8			
	Low pressure gas	3/4	7/8	1			1 - 1/8			
	High pressure gas	5/8	3/4	7/8				1		

Electrical features	Unit	RAS-8FSXNSE	RAS-10FSXNSE	RAS-12FSXNSE	RAS-14FSXNSE	RAS-16FSXNSE	RAS-18FSXNSE	RAS-20FSXNSE	RAS-22FSXNSE	RAS-24FSXNSE
Power supply	-	3N - 400V 50Hz								
Max. current	A	15.50	21.50	24	29.50	33	37.50	44.50	45	53
Recommended fuse size	A	20.0	25.0		32.0	40.0		50		63
Indoor/outdoor connection (shielded) ⁽⁴⁾	mm	2 x 0.75								

⁽¹⁾ When set to 20°C with a connection rate of 100%. ⁽²⁾ Anechoic chamber readings taken 1 m from the front of the appliance. ⁽³⁾ Depending on the application; refer to the technical documentation. ⁽⁴⁾ Shielding must be renewed every 300 m.

controls and compatible accessories (see the tab VRF TWIN controls)



Condensate drain kit
DBS-TP10A
Compatible with
FSXNSE and FSXNPE



Multi kit
See page 264

		RAS-26FSXNSE	RAS-28FSXNSE	RAS-30FSXNSE	RAS-32FSXNSE	RAS-34FSXNSE	RAS-36FSXNSE	RAS-38FSXNSE	RAS-40FSXNSE	
Unit 1 name		RAS-12FSXNSE	RAS-12FSXNSE	RAS-12FSXNSE	RAS-14FSXNSE	RAS-16FSXNSE	RAS-18FSXNSE	RAS-14FSXNSE	RAS-18FSXNSE	
Unit 2 name		RAS-14FSXNSE	RAS-16FSXNSE	RAS-18FSXNSE	RAS-18FSXNSE	RAS-18FSXNSE	RAS-18FSXNSE	RAS-24FSXNSE	RAS-22FSXNSE	
Performance, cooling		Unit								
Nominal Cooling capacity	kW	73	77.5	85	90	95	100	106	112	
Rated power input Cooling	kW	23.38	22.44	24.24	29.58	28.77	29.85	36.71	35.52	
EER	-	3.12	3.45	3.51	3.04	3.30	3.35	2.89	3.15	
SEER	-	7.30	7.10	7.11	7.36	7.18	7.20	6.63	6.93	
Working range in Cooling	-	-10°C / 48°C DB								
Performance, heating										
Nominal Heating capacity	kW	82.5	90	95	100	106	112	118	125	
Rated power input Heating	kW	21.18	24.67	26.59	28.77	31.86	34.04	33.55	38.65	
Power at -7°C ⁽¹⁾	kW	59.54	63.70	67.25	72.09	76.41	79.46	81.66	88.68	
Power at -15°C (or -20°C) ⁽¹⁾	kW	45.8	48.65	51.31	55.15	58.46	60.40	62.61	67.50	
COP	-	3.90	3.65	3.57	3.48	3.33	3.29	3.52	3.23	
SCOP	-	4.39	4.35	4.22	4.30	4.28	4.18	4.45	4.30	
Working range in Heating	-	-20°C / 15°C WB								
Technical features										
Airflow	m ³ /h	11140 + 14340	11140 + 15360		14340 + 15360	15360 + 15360		14340 + 20280	15360 + 19740	
Adjustable static pressure	Pa	30 / 60 / 80								
Number of fans	-	3			4					
Sound power	dB(A)	87			89				88	
Sound pressure ⁽²⁾ (Night mode)	dB(A)	64.50 (58)	64.50 (58.50)	66 (58)	67 (60)	67 (62)	68 (60)	68 (61)	67.50 (61.50)	
Dimensions (H x L x D)	mm	1725 x 2198 x 784			1725 x 2458 x 784			1725 x 2848 x 784		
Net weight	kg	233 + 287	233 + 329	233 + 330	287 + 330	329 + 330	330 + 330	287 + 399	330 + 398	
Type of compressor	-	DC Scroll Inverter								
Compressor number	-	2	3			4				
Max. number of indoor units that can be connected	-	64								
Connection ratio (min - max) ⁽³⁾	-	50 - 130%								
Refrigeration characteristics										
Refrigerant	-	R410A								
Refrigerant charge	kg	16.1	17.1	17.9	19.6	20.6	21.4	20.5	22	
Diameter of pipes	Liquid	inches 3/4								
	Low pressure gas	inches 1 - 1/4					inches 1 - 1/2			
	High pressure gas	inches 1 - 1/8						inches 1 - 1/4		
Electrical features										
Power supply	-	3N - 400V 50Hz								
Max. current	A	53	56.5	61	66.5	70.5	75	82.5	82	
Recommended fuse size	A	63			80			100		
Indoor/outdoor connection (shielded) ⁽⁴⁾	mm	2 x 0.75								

⁽¹⁾ When set to 20°C with a connection rate of 100%. ⁽²⁾ Anechoic chamber readings taken 1 m from the front of the appliance.⁽³⁾ Depending on the application; refer to the technical documentation. ⁽⁴⁾ Shielding must be renewed every 300 m.

	RAS-42FSXNSE	RAS-44FSXNSE	RAS-46FSXNSE	RAS-48FSXNSE	RAS-50FSXNSE	RAS-52FSXNSE	RAS-54FSXNSE
Unit 1 name	RAS-18FSXNSE	RAS-22FSXNSE	RAS-22FSXNSE	RAS-24FSXNSE	RAS-14FSXNSE	RAS-16FSXNSE	RAS-18FSXNSE
Unit 2 name	RAS-24FSXNSE	RAS-22FSXNSE	RAS-24FSXNSE	RAS-24FSXNSE	RAS-18FSXNSE	RAS-18FSXNSE	RAS-18FSXNSE
Unit 3 name	-	-	-	-	RAS-18FSXNSE	RAS-18FSXNSE	RAS-18FSXNSE

Performance, cooling Unit

Nominal Cooling capacity	kW	118	122	128	136	140	145	150
Rated power input Cooling	kW	37.65	40.53	42.67	45.48	44.5	43.7	44.78
EER	-	3.13	3.01	3	2.99	3.15	3.32	3.35
SEER	-	6.57	6.75	6.45	6.19	7.30	7.18	7.20
Working range in Cooling	-	-10°C / 48°C DB						

Performance, heating

Nominal Heating capacity	kW	132	140	145	150	155	160	165
Rated power input Heating	kW	39.37	43.89	43.97	44.12	45.49	48.28	50.15
Power at -7°C ⁽¹⁾	kW	90.38	99.32	99.62	100.06	111.10	113.51	117.06
Power at -15°C (or -20°C) ⁽¹⁾	kW	68.9	75.58	76.01	76.45	84.81	86.32	88.98
COP	-	3.35	3.19	3.30	3.40	3.41	3.31	3.29
SCOP	-	4.31	4.42	4.43	4.43	4.26	4.25	4.18
Working range in Heating	-	-20°C / 15°C WB						

Technical features

Airflow	m³/h	15360 + 20880	19740 + 19740	19740 + 20880	20880 + 20880	14340 + 15360 + 15360		
Adjustable static pressure	Pa	30 / 60 / 80						
Number of fans	-	4				6		
Sound power	dB(A)	89	87	88	89	90	90	91
Sound pressure ⁽²⁾ (Night mode)	dB(A)	68.50 (61)	67 (62)	68 (62)	69 (62)	69 (62)	69 (62)	70 (62)
Dimensions (H x L x D)	mm	1725 x 2848 x 784	1725 x 3238 x 784	1725 x 3238 x 784	1725 x 3238 x 784	1725 x 3697 x 784	1725 x 3697 x 784	1725 x 3697 x 784
Net weight	kg	330 + 399	398 + 398	398 + 399	399 + 399	287 + 330 + 330	329 + 330 + 330	330 + 330 + 330
Type of compressor	-	DC Scroll Inverter						
Compressor number	-	4				5	6	
Max. number of indoor units that can be connected	-	64						
Connection ratio (min - max) ⁽³⁾	-	50 - 130%						

Refrigeration characteristics

Refrigerant	-	R410A						
Refrigerant charge	kg	22.30	22.60	22.90	23.20	30.30	31.30	32.10
Diameter of pipes	Liquid	inches	3/4					
	Low pressure gas	inches	1 - 1/2					
	High pressure gas	inches	1 - 1/4					

Electrical features

Power supply	-	3N - 400V 50Hz						
Max. current	A	90.50	89.50	98	106	104	108	112
Recommended fuse size	A	100			125			
Indoor/outdoor connection (shielded) ⁽⁴⁾	mm	2 x 0.75						

⁽¹⁾ When set to 20°C with a connection rate of 100%. ⁽²⁾ Anechoic chamber readings taken 1 m from the front of the appliance.

⁽³⁾ Depending on the application; refer to the technical documentation. ⁽⁴⁾ Shielding must be renewed every 300 m.

To find out the features of **56 Hp** to **96 Hp** outdoor units, please refer to the technical documentation.

Pipe kits

VRF SET FREE Sigma Standard

Composition of multi-module outdoor units

Outdoor unit	2-pipe combination	Multikit	Outdoor unit	3-pipe combinations.	Multikit
RAS-8FSXNSE	Single module	-	RAS-8FSXNSE-3P	Single module	-
RAS-10FSXNSE	Single module	-	RAS-10FSXNSE-3P	Single module	-
RAS-12FSXNSE	Single module	-	RAS-12FSXNSE-3P	Single module	-
RAS-14FSXNSE	Single module	-	RAS-14FSXNSE-3P	Single module	-
RAS-16FSXNSE	Single module	-	RAS-16FSXNSE-3P	Single module	-
RAS-18FSXNSE	Single module	-	RAS-18FSXNSE-3P	Single module	-
RAS-20FSXNSE	Single module	-	RAS-20FSXNSE-3P	Single module	-
RAS-22FSXNSE	Single module	-	RAS-22FSXNSE-3P	Single module	-
RAS-24FSXNSE	Single module	-	RAS-24FSXNSE-3P	Single module	-
RAS-26FSXNSE	RAS-14FSXNSE - RAS-12FSXNSE	MC-21AN1	RAS-26FSXNSE-3P	RAS-14FSXNSE - RAS-12FSXNSE	MC-21XN1
RAS-28FSXNSE	RAS-16FSXNSE - RAS-12FSXNSE	MC-21AN1	RAS-28FSXNSE-3P	RAS-16FSXNSE - RAS-12FSXNSE	MC-21XN1
RAS-30FSXNSE	RAS-18FSXNSE - RAS-12FSXNSE	MC-21AN1	RAS-30FSXNSE-3P	RAS-18FSXNSE - RAS-12FSXNSE	MC-21XN1
RAS-32FSXNSE	RAS-18FSXNSE - RAS-14FSXNSE	MC-21AN1	RAS-32FSXNSE-3P	RAS-18FSXNSE - RAS-14FSXNSE	MC-21XN1
RAS-34FSXNSE	RAS-18FSXNSE - RAS-16FSXNSE	MC-21AN1	RAS-34FSXNSE-3P	RAS-18FSXNSE - RAS-16FSXNSE	MC-21XN1
RAS-36FSXNSE	RAS-18FSXNSE - RAS-18FSXNSE	MC-21AN1	RAS-36FSXNSE-3P	RAS-18FSXNSE - RAS-18FSXNSE	MC-21XN1
RAS-38FSXNSE	RAS-24FSXNSE - RAS-14FSXNSE	MC-21AN1	RAS-38FSXNSE-3P	RAS-24FSXNSE - RAS-14FSXNSE	MC-21XN1
RAS-40FSXNSE	RAS-22FSXNSE - RAS-18FSXNSE	MC-21AN1	RAS-40FSXNSE-3P	RAS-22FSXNSE - RAS-18FSXNSE	MC-21XN1
RAS-42FSXNSE	RAS-24FSXNSE - RAS-18FSXNSE	MC-21AN1	RAS-42FSXNSE-3P	RAS-24FSXNSE - RAS-18FSXNSE	MC-21XN1
RAS-44FSXNSE	RAS-22FSXNSE - RAS-22FSXNSE	MC-21AN1	RAS-44FSXNSE-3P	RAS-22FSXNSE - RAS-22FSXNSE	MC-21XN1
RAS-46FSXNSE	RAS-24FSXNSE - RAS-22FSXNSE	MC-21AN1	RAS-46FSXNSE-3P	RAS-24FSXNSE - RAS-22FSXNSE	MC-21XN1
RAS-48FSXNSE	RAS-24FSXNSE - RAS-24FSXNSE	MC-21AN1	RAS-48FSXNSE-3P	RAS-24FSXNSE - RAS-24FSXNSE	MC-21XN1
RAS-50FSXNSE	RAS-18FSXNSE - RAS-18FSXNSE - RAS-14FSXNSE	MC-30AN1	RAS-50FSXNSE-3P	RAS-18FSXNSE - RAS-18FSXNSE - RAS-14FSXNSE	MC-30XN1
RAS-52FSXNSE	RAS-18FSXNSE - RAS-18FSXNSE - RAS-16FSXNSE	MC-30AN1	RAS-52FSXNSE-3P	RAS-18FSXNSE - RAS-18FSXNSE - RAS-16FSXNSE	MC-30XN1
RAS-54FSXNSE	RAS-18FSXNSE - RAS-18FSXNSE - RAS-18FSXNSE	MC-30AN1	RAS-54FSXNSE-3P	RAS-18FSXNSE - RAS-18FSXNSE - RAS-18FSXNSE	MC-30XN1

Part numbers of pipe kit accessories

Multikit



2 pipes

3 pipes

E-102SN4

E-52XN3

E-162SN4

E-102XN3

E-242SN3

E-162XN3

E-302SN3

E-202XN3

MW-NP2682A3

E-242XN3

E-322XN3

Header



2 pipes

3 pipes

MH-84AN1

MH-108XN

MH-108AN

Compatible accessories



Locking connectors

VRF SET FREE Sigma High-Efficiency



Highly energy-efficient

Thanks to its seasonal energy efficiency performance (SEER 8.33 and SCOP 5.06), the High-Efficiency Sigma range will guarantee running cost savings over standard ranges.

The biggest range

Exclusive to Hitachi with single modules from 5 Hp and a possible combination of up to 54 Hp for 3-pipe and 72 Hp for 2-pipe versions.

Exclusive solution

3-pipe / 2-pipe universal outdoor unit meets the needs of both energy recovery applications and reversible heat pump ones from the same outdoor, allowing for sites to be retrofitted from heat pump to heat recovery or vice versa without having to change the outdoor.

Advanced anti-corrosion treatment

With its triple coating, SIGMA VRF offers the best protection on the market for coastal locations.

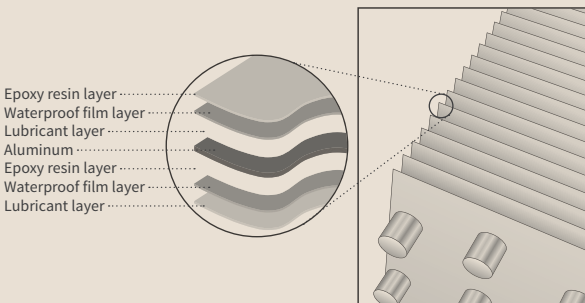

Large operating ranges

Outside temperature operating range

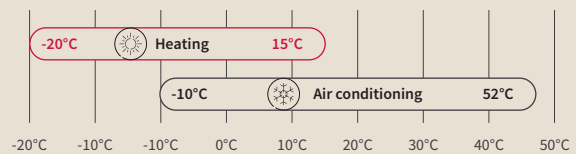

Variable evaporation temperature

The control logic built into SIGMA VRF units saves more energy and increases user comfort the whole year round. If the thermal requirements of the internal rooms are low then the system will automatically select a high evaporating temperature which will increase seasonal efficiency and reduce cold drafts. If the thermal needs of indoor rooms change, like a meeting room is needed with a high occupancy level, the system will automatically detect this and decrease the evaporating temperature. This will ensure the cooling load of the room can be met quickly and occupants remain comfortable. This smart refrigerant control is complemented by the GENTLE COOL setting, in which users set the minimum air off temperature per fan coil to avoid cold drafts at all times, SIGMA is now the most comfortable VRF on the market.

Backup function

Isolates an outdoor unit for maintenance while other units continue to operate.

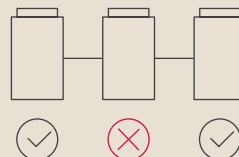

Outdoor units

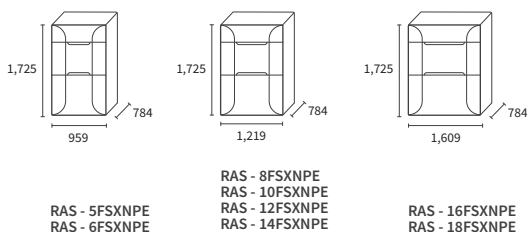

Performance, cooling	Unit	RAS-5FSXNPE	RAS-6FSXNPE	RAS-8FSXNPE	RAS-10FSXNPE	RAS-12FSXNPE	RAS-14FSXNPE	RAS-16FSXNPE	RAS-18FSXNPE
Nominal Cooling capacity	kW	14	16	22.4	28	33.5	40	45	50
Rated power input Cooling	kW	2.90	3.37	5.05	6.18	8.44	11.53	11.51	12.79
EER	-	4.82	4.75	4.44	4.53	3.97	3.47	3.91	3.91
SEER	-	8.33	8.00	7.97	8.06	7.91	7.69	7.76	7.60
Working range in Cooling	-	-10°C / 52°C DB							

Performance, heating

Nominal Heating capacity	kW	16.00	18.00	25.00	31.50	37.5	45	50	56
Rated power input Heating	kW	2.80	3.52	5.08	6.65	8.01	10.84	12.92	14.97
Power at -7°C ⁽¹⁾	kW	13.38	15.04	20.92	25.10	27.78	34.93	40.06	41.46
Power at -15°C (or -20°C) ⁽¹⁾	kW	10.70	12.10	16.80	19.80	21.40	30.20	31.50	31.90
COP	-	5.72	5.12	4.92	4.74	4.68	4.15	3.87	3.74
SCOP	-	5.06	4.58	4.55	4.73	4.81	4.63	4.84	4.81
Working range in Heating	-	-20°C / 15°C WB							

Technical features

Airflow	m ³ /h	9000	10200	11100	13140		14580	19560	21720
Adjustable static pressure	Pa	30 / 60 / 80							
Number of fans	-	1			2				
Sound power	dB(A)	75	78	77	82	83	85	85	86
Sound pressure ⁽²⁾ (Night mode)	dB(A)	54 (49)	56 (51)	55 (50)	59 (54)	60 (55)	62 (57)	65 (60)	65 (60)
Dimensions (H x L x D)	mm	1725 x 959 x 784			1725 x 1219 x 784			1725 x 1609 x 784	
Net weight	kg	210		274	278	282	292	369	384
Type of compressor	-	DC Scroll Inverter							
Compressor number	-	1						2	
Max. number of indoor units that can be connected	-	16	19	26	32	39	45	52	58
Connection ratio (min - max) ⁽³⁾	-	50 - 150%							

Refrigeration characteristics

Refrigerant	-	R410A							
Refrigerant charge	kg	4.7	5	8.5	8.5	9.3	9.3	10	10.6
Diameter of pipes	Liquid	inches	3/8			1/2			5/8
	Low pressure gas	inches	5/8	3/4		7/8	1-1/8		
	High pressure gas	inches	1/2	5/8		3/4	7/8		

Electrical features

Power supply	-	3N - 400V 50Hz							
Max. current	A	11.5	12.0	15.0	19.0	23.0	28.0	33.0	34.5
Recommended fuse size	A	16			20	25	32	40	
Indoor/outdoor connection (shielded) ⁽⁴⁾	mm	2 x 0.75							

⁽¹⁾ When set to 20°C with a connection rate of 100%. ⁽²⁾ Anechoic chamber readings taken 1 m from the front of the appliance. ⁽³⁾ Depending on the application; refer to the technical documentation. ⁽⁴⁾ Shielding must be renewed every 300 m.

Controls and compatible accessories (see the tab VRF TWIN controls)

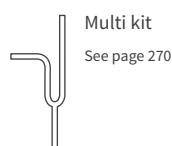
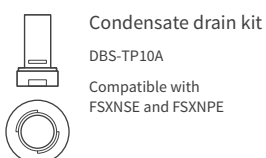

RAS-20FSXNPE RAS-22FSXNPE RAS-24FSXNPE RAS-26FSXNPE RAS-28FSXNPE RAS-30FSXNPE RAS-32FSXNPE RAS-34FSXNPE RAS-36FSXNPE

Unit 1 name RAS-10FSXNPE RAS-10FSXNPE RAS-12FSXNPE RAS-10FSXNPE RAS-12FSXNPE RAS-12FSXNPE RAS-14FSXNPE RAS-16FSXNPE RAS-18FSXNPE

Unit 2 name RAS-10FSXNPE RAS-12FSXNPE RAS-12FSXNPE RAS-16FSXNPE RAS-16FSXNPE RAS-18FSXNPE RAS-18FSXNPE RAS-18FSXNPE RAS-18FSXNPE

Performance, cooling **Unit**

Nominal Cooling capacity	kW	56	61.5	67	73	77.5	85	90	95	100
Rated power input Cooling	kW	12.36	14.62	16.88	17.69	19.69	21.61	24.32	24.30	25.58
EER	-	4.53	4.21	3.97	4.13	3.94	3.93	3.70	3.91	3.91
SEER	-	8.06	7.97	7.91	7.92	7.71	7.49	7.62	7.83	7.60
Working range in Cooling	-	-10°C / 52°C B								

Performance, heating

Nominal Heating capacity	kW	63	69	77.5	82.5	90	95	100	106	112
Rated power input Heating	kW	13.29	14.66	16.56	19.81	21.53	23.35	25.56	27.89	29.95
Power at -7°C ⁽¹⁾	kW	50.2	52.88	57.41	65.96	69.76	70.35	75.64	81.52	82.92
Power at -15°C (or -20°C) ⁽¹⁾	kW	39.6	41.2	44.23	51.93	54.39	54.16	61.49	63.40	63.80
COP	-	4.74	4.71	4.68	4.17	4.18	4.07	3.91	3.80	3.74
SCOP	-	4.76	4.76	4.81	4.78	4.82	4.71	4.63	4.72	4.64
Working range in Heating	-	-20°C / 15°C WB								

Technical features

Airflow	m ³ /h	13140 + 13140			13140 + 19560		13141 + 21720	14580 + 21720	19560 + 21720	21720 + 21720	
Adjustable static pressure	Pa	30 / 60 / 80									
Number of fans	-	4									
Sound power	dB(A)	85	86	86	87		88	89			
Sound pressure ⁽²⁾ (Night mode)	dB(A)	62 (57)	62.5 5 (57.5)	63 (58)	66 (61)		66 (61)	67 (62)	68 (63)		
Dimensions (H x L x D)	mm	1725 x 2458 x 784				1725 x 2848 x 784			1725 x 3238 x 784		
Net weight	kg	278 + 278	278 + 282	282 + 282	278 + 369	282 + 369	282 + 384	297 + 384	369 + 384	384 + 384	
Type of compressor	-	DC Scroll Inverter									
Compressor number	-	2			3			4			
Max. number of indoor units that can be connected	-	64									
Connection ratio (min - max) ⁽³⁾	-	50 - 150%									

Refrigeration characteristics

Refrigerant	-	R410A								
Refrigerant charge	kg	17	17.8	18.6	18.5	19.3	19.9	19.9	20.6	21.2
Diameter of pipes	Liquid	inches	5/8			3/4				
	Low pressure gas	inches	1-1/8			1-1/4				1-1/2
	High pressure gas	inches	7/8	1			1-1/8			

Electrical features

Power supply	-	3N - 400V 50Hz								
Max. current	A	38.0	42.0	46.0	51.5	55.5	57.0	62.0	67.0	68.5
Recommended fuse size	A	40	50		63			80		
Indoor/outdoor connection (shielded) ⁽⁴⁾	mm	2 x 0.75								

⁽¹⁾ When set to 20°C with a connection rate of 100%. ⁽²⁾ Anechoic chamber readings taken 1 m from the front of the appliance.⁽³⁾ Depending on the application; refer to the technical documentation. ⁽⁴⁾ Shielding must be renewed every 300 m.

	RAS-38FSXNPE	RAS-40FSXNPE	RAS-42FSXNPE	RAS-44FSXNPE	RAS-46FSXNPE	RAS-48FSXNPE	RAS-50FSXNPE	RAS-52FSXNPE	RAS-54FSXNPE
Unit 1 name	RAS-12FSXNPE	RAS-12FSXNPE	RAS-14FSXNPE	RAS-12FSXNPE	RAS-14FSXNPE	RAS-12FSXNPE	RAS-14FSXNPE	RAS-16FSXNPE	RAS-18FSXNPE
Unit 2 name	RAS-12FSXNPE	RAS-14FSXNPE	RAS-14FSXNPE	RAS-14FSXNPE	RAS-14FSXNPE	RAS-18FSXNPE	RAS-18FSXNPE	RAS-18FSXNPE	RAS-18FSXNPE
Unit 3 name	RAS-14FSXNPE	RAS-14FSXNPE	RAS-14FSXNPE	RAS-18FSXNPE	RAS-18FSXNPE	RAS-18FSXNPE	RAS-18FSXNPE	RAS-18FSXNPE	RAS-18FSXNPE

Performance, cooling	Unit									
Nominal Cooling capacity	kW	106	112	118	122	128	136	140	145	150
Rated power input Cooling	kW	28.12	31.11	34.01	32.36	35.29	34.65	37.10	37.08	38.36
EER	-	3.77	3.60	3.47	3.77	3.63	3.92	3.77	3.91	
SEER	-	7.67			7.64		7.61		7.75	7.60
Working range in Cooling	-	-10°C / 52°C DB								

Performance, heating										
Nominal Heating capacity	kW	118	125	132	140	145	150	155	160	165
Rated power input Heating	kW	26.40	29.14	31.80	34.2	36.41	38.09	40.27	42.34	44.12
Power at -7°C ⁽¹⁾	kW	88.98	95.73	102.47	105.30	110.57	114.09	116.36	121.47	122.17
Power at -15°C (or -20°C) ⁽¹⁾	kW	71.78	80.19	88.59	84.41	91.67	85.48	92.80	94.12	93.99
COP	-	4.47	4.29	4.15	4.09	3.98	3.94	3.85	3.78	3.74
SCOP	-	4.17	4.68	4.63	4.68	4.63	4.68	4.64	4.70	4.64
Working range in Heating	-	-20°C / 15°C WB								

Technical features											
Airflow	m ³ /h	13140 + 13140 + 14580	13140 + 14580 + 14580	14580 + 14580 + 14580	13140 + 14580 + 21720	14580 + 14580 + 21720	13140 + 21720 + 21720	14580 + 21720 + 21720	19560 + 21720 + 21720	21720 + 21720 + 21720	
Adjustable static pressure	Pa	30 / 60 / 80									
Number of fans	-	6									
Sound power	dB(A)	89			90					91	
Sound pressure ⁽²⁾ (Night mode)	dB(A)	65.5 (60.5)	66 (61)	67 (62)	67.5 (62.5)	68 (63)	68.5 (63.5)	69 (64)	70 (65)	70 (65)	
Dimensions (H x L x D)	mm	1725 x 3697 x 784			1725 x 4087 x 784		1725 x 4477 x 784		1725 x 4867 x 784		
Net weight	kg	282 + 282 + 297	282 + 297 + 297	297 + 297 + 297	282 + 297 + 384	297 + 297 + 384	282 + 384 + 384	297 + 384 + 384	369 + 384 + 384	384 + 384 + 384	
Type of compressor	-	DC Scroll Inverter									
Compressor number	-	3			4		5		6		
Max. number of indoor units that can be connected	-	64									
Connection ratio (min - max) ⁽³⁾	-	50 - 150%									

Refrigeration characteristics										
Refrigerant	-	R410A								
Refrigerant charge	kg	27.9			29.2	29.2	30.5		31.2	31.8
Diameter of pipes	Liquid	inches				3/4				
	Low pressure gas	inches				1 - 1/2				
	High pressure gas	inches				1 - 1/4				

Electrical features											
Power supply	-	3N - 400V 50Hz									
Max. current	A	73.5	78.5	83.0	85.0	89.5	91.0	96.0	101.0	103.0	
Recommended fuse size	A	80			100				125		
Indoor/outdoor connection (shielded) ⁽⁴⁾	mm	2 x 0.75									

⁽¹⁾ When set to 20°C with a connection rate of 100%. ⁽²⁾ Anechoic chamber readings taken 1 m from the front of the appliance.

⁽³⁾ Depending on the application; refer to the technical documentation. ⁽⁴⁾ Shielding must be renewed every 300 m.

To find out the features of 56 Hp to 72 Hp outdoor units, please refer to the technical documentation.

Pipe kits

VRF SET FREE SIGMA High-Performance

Composition of multi-module outdoor units

Outdoor unit	2-pipe combination	Multikit	Outdoor unit	3-pipe combinations.	Multikit
RAS-5FSXNPE	Single module	-	RAS-5FSXNPE-3P	Single module	-
RAS-6FSXNPE	Single module	-	RAS-6FSXNPE-3P	Single module	-
RAS-8FSXNPE	Single module	-	RAS-8FSXNPE-3P	Single module	-
RAS-10FSXNPE	Single module	-	RAS-10FSXNPE-3P	Single module	-
RAS-12FSXNPE	Single module	-	RAS-12FSXNPE-3P	Single module	-
RAS-14FSXNPE	Single module	-	RAS-14FSXNPE-3P	Single module	-
RAS-16FSXNPE	Single module	-	RAS-16FSXNPE-3P	Single module	-
RAS-18FSXNPE	Single module	-	RAS-18FSXNPE-3P	Single module	-
RAS-20FSXNPE	RAS-10FSXNPE - RAS-10FSXNPE	MC-20AN1	RAS-20FSXNPE-3P	RAS-10FSXNPE - RAS-10FSXNPE	MC-20XN1
RAS-22FSXNPE	RAS-10FSXNPE - RAS-12FSXNPE	MC-20AN1	RAS-22FSXNPE-3P	RAS-10FSXNPE - RAS-12FSXNPE	MC-20XN1
RAS-24FSXNPE	RAS-12FSXNPE - RAS-12FSXNPE	MC-20AN1	RAS-24FSXNPE-3P	RAS-12FSXNPE - RAS-12FSXNPE	MC-20XN1
RAS-26FSXNPE	RAS-16FSXNPE - RAS-10FSXNPE	MC-21AN1	RAS-26FSXNPE-3P	RAS-16FSXNPE - RAS-10FSXNPE	MC-21XN1
RAS-28FSXNPE	RAS-16FSXNPE - RAS-12FSXNPE	MC-21AN1	RAS-28FSXNPE-3P	RAS-16FSXNPE - RAS-12FSXNPE	MC-21XN1
RAS-30FSXNPE	RAS-18FSXNPE - RAS-12FSXNPE	MC-21AN1	RAS-30FSXNPE-3P	RAS-18FSXNPE - RAS-12FSXNPE	MC-21XN1
RAS-32FSXNPE	RAS-18FSXNPE - RAS-14FSXNPE	MC-21AN1	RAS-32FSXNPE-3P	RAS-18FSXNPE - RAS-14FSXNPE	MC-21XN1
RAS-34FSXNPE	RAS-18FSXNPE - RAS-16FSXNPE	MC-21AN1	RAS-34FSXNPE-3P	RAS-18FSXNPE - RAS-16FSXNPE	MC-21XN1
RAS-36FSXNPE	RAS-18FSXNPE - RAS-18FSXNPE	MC-21AN1	RAS-36FSXNPE-3P	RAS-18FSXNPE - RAS-18FSXNPE	MC-21XN1
RAS-38FSXNPE	RAS-14FSXNPE - RAS-12FSXNPE - RAS-12FSXNPE	MC-30AN1	RAS-38FSXNPE-3P	RAS-14FSXNPE - RAS-12FSXNPE - RAS-12FSXNPE	MC-30XN1
RAS-40FSXNPE	RAS-14FSXNPE - RAS-14FSXNPE - RAS-12FSXNPE	MC-30AN1	RAS-40FSXNPE-3P	RAS-14FSXNPE - RAS-14FSXNPE - RAS-12FSXNPE	MC-30XN1
RAS-42FSXNPE	RAS-14FSXNPE - RAS-14FSXNPE - RAS-14FSXNPE	MC-30AN1	RAS-42FSXNPE-3P	RAS-14FSXNPE - RAS-14FSXNPE - RAS-14FSXNPE	MC-30XN1
RAS-44FSXNPE	RAS-18FSXNPE - RAS-14FSXNPE - RAS-12FSXNPE	MC-30AN1	RAS-44FSXNPE-3P	RAS-18FSXNPE - RAS-14FSXNPE - RAS-12FSXNPE	MC-30XN1
RAS-46FSXNPE	RAS-18FSXNPE - RAS-14FSXNPE - RAS-14FSXNPE	MC-30AN1	RAS-46FSXNPE-3P	RAS-18FSXNPE - RAS-14FSXNPE - RAS-14FSXNPE	MC-30XN1
RAS-48FSXNPE	RAS-18FSXNPE - RAS-18FSXNPE - RAS-12FSXNPE	MC-30AN1	RAS-48FSXNPE-3P	RAS-18FSXNPE - RAS-18FSXNPE - RAS-12FSXNPE	MC-30XN1
RAS-50FSXNPE	RAS-18FSXNPE - RAS-18FSXNPE - RAS-14FSXNPE	MC-30AN1	RAS-50FSXNPE-3P	RAS-18FSXNPE - RAS-18FSXNPE - RAS-14FSXNPE	MC-30XN1
RAS-52FSXNPE	RAS-18FSXNPE - RAS-18FSXNPE - RAS-16FSXNPE	MC-30AN1	RAS-52FSXNPE-3P	RAS-18FSXNPE - RAS-18FSXNPE - RAS-16FSXNPE	MC-30XN1
RAS-54FSXNPE	RAS-18FSXNPE - RAS-18FSXNPE - RAS-18FSXNPE	MC-30AN1	RAS-54FSXNPE-3P	RAS-18FSXNPE - RAS-18FSXNPE - RAS-18FSXNPE	MC-30XN1

Part numbers of cooler accessories

Multikit



2 pipes

3 pipes

E-102SN4

E-52XN3

E-162SN4

E-102XN3

E-242SN3

E-162XN3

E-302SN3

E-202XN3

MW-NP2682A3

E-242XN3

E-322XN3

Header



2 pipes

3 pipes

MH-84AN1

MH-108XN

MH-108AN

Compatible accessories



Locking connectors

VRF SET FREE Single CH boxes

Compatible with Sigma and SET FREE Mini 3-pipe ranges (8 to 12 Hp)

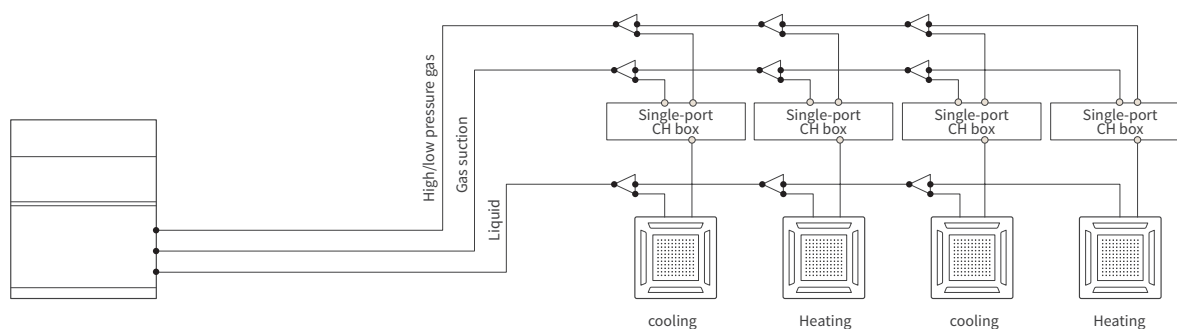

Description

- CH box range with 1 port.
- Up to 8 indoor units per CH box.
- Compact.
- Lightweight.
- Connect 2-pipes only (gas pipes).
- No condensate connection.

- Long pipe lengths possible.
- Very low sound level: 33 dB(A).
- Flare type pipe connections.

Mono CH boxes	Part no.	CH-AP160SSX	CH-AP280SSX
Max. capacity in cooling mode	Hp (kW)	16.0	28.0
Number of indoor units that can be connected*		1 ~ 7	1 ~ 8
Max. pipe length between CH box and indoor units	m	40	
Difference in height of indoor units connected to the same CH box	m	< 4	
Height difference between each CH box or between a CH box and an indoor unit	m	< 15	
Dimensions (H x L x D)	mm	191 x 301 x 214	
Weight	kg	6	
Diameter of refrigeration pipes – outdoor unit - Gas only	inches	5/8 - 3/4	
Diameter of refrigeration pipes – indoor unit - Gas only	inches	5/8	3/4
Sound pressure level	dB(A)	33 (46 max**)	

* If connecting multiple indoor units per branch, use the Hitachi multikits referenced P. 270.

** Max. noise means the maximum operating noise level of the CH box emitted when the unit is in simultaneous cooling and heating or in defrost mode.

VRF SET FREE Multi CH boxes

Compatible with Sigma and SET FREE Mini 3-pipe ranges (8 to 12 Hp)

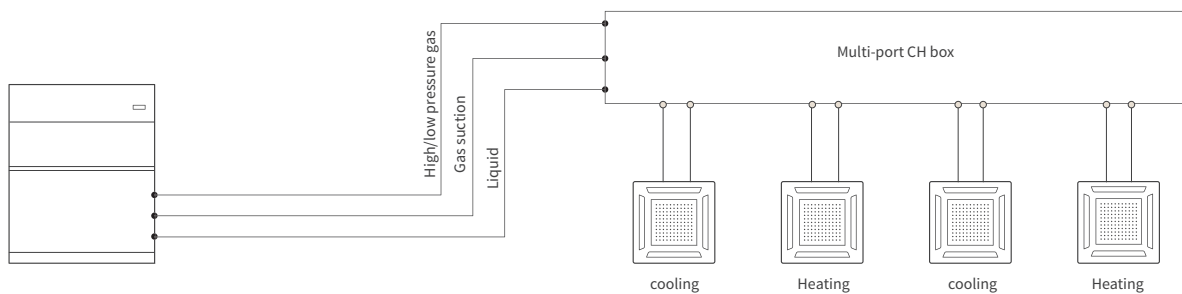
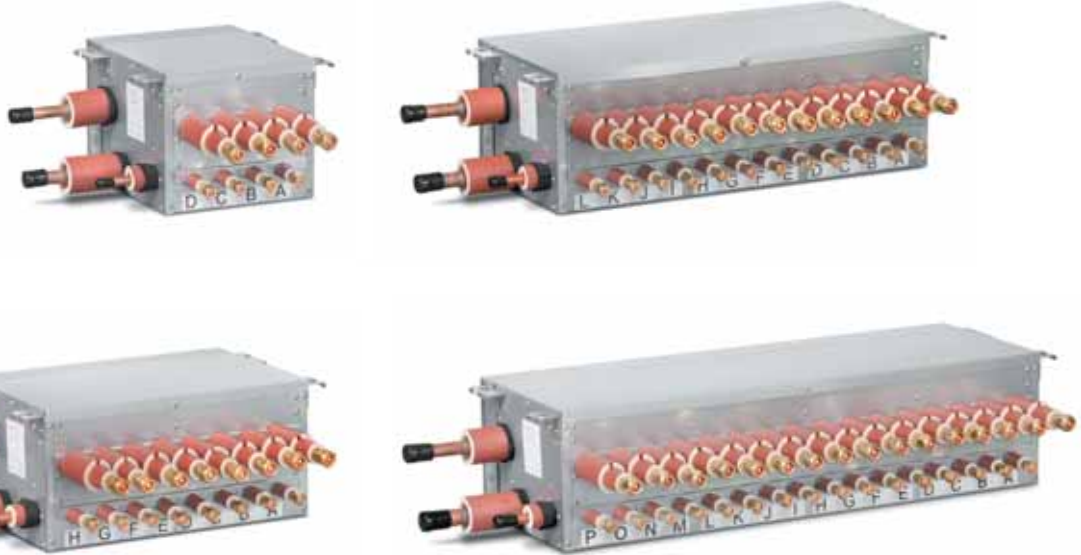

Description

- Range of multi-port CH boxes.
- Up to 96 indoor units per CH box.
- Low-height.
- Low volume.
- No condensate connection.

- Lightweight.
- Very low sound level: 31 dB(A).
- Refrigerant pipe connections brazed (outdoor unit) and flare type (indoor unit).

Multi CH boxes	Part no.	CH-AP04MSSX	CH-AP08MSSX	CH-AP12MSSX	CH-AP16MSSX
Number of branches		4	8	12	16
Number of units per branch*		1 ~ 6	1 ~ 6	1 ~ 6	1 ~ 6
Total max. Cooling capacity per CH box	kW	44.8	85	85	85
Total max. Cooling capacity per branch	kW			16	
Max. pipe length between CH box & indoor units	m			40	
Difference in height of indoor units connected to the same CH box	m			< 4	
Height difference between each CH box or between a CH box and an indoor unit	m			< 15	
Dimensions (H x L x D)	mm	260 x 303 x 352	260 x 543 x 352	260 x 783 x 352	260 x 1023 x 352
Weight	kg	14	25	36	47
Diameters of refrigeration pipes – outdoor unit (Dis - Suc - Liq)	inches	7/8 - 1 1/8 - 1/2	7/8 - 1 1/8 - 1/2	1 - 1 1/8 - 5/8	1 1/8 - 1 1/4 - 3/4
Diameters of refrigeration pipes – indoor unit (Gas - Liq)	inches	5/8 - 3/8			
Sound pressure level	dB(A)	31 (43 max**)	31 (46 max**)	34 (48 max**)	34 (49 max**)

* If connecting multiple indoor units per branch, use the Hitachi multikits referenced P. 270.

** Max. noise means the maximum operating noise level of the CH box emitted when the unit is in simultaneous cooling and heating or in defrost mode.

Design rules for refrigeration piping

Permissible length of pipes

Item	Symbol	Permissible length of pipes	
		≤ Number of indoor units recommended*	≥ Number of indoor units recommended*
Total length of piping	Actual total length of liquid piping	≤ 1000m ⁽³⁾	≤ 300m ⁽³⁾
Max. pipe length	Actual length	≤ 165m	≤ 165m
	Equivalent length	≤ 190m	≤ 190m
Max. length of piping between the multi-kit of the first branch and each indoor unit	L2	≤ 90m	≤ 40m
Max. pipe length between multi-kits and indoor units	L3	≤ 40m	≤ 30m
Total pipe length between the CH-Box and each indoor unit	L4 (e + f + g + h + i)	≤ 40m	≤ 30m
Pipe length between the piping connection kit 1 and each outdoor unit	La, Lb, Lc	≤ 10m	≤ 10m
Height difference between outdoor units and indoor units	Outdoor unit is higher	≤ 50m ⁽¹⁾	≤ 50m ⁽¹⁾
	Outdoor unit is lower	≤ 40m	≤ 40m
Height difference between indoor units	H2	≤ 30m	≤ 30m
Height difference between the CH box and indoor unit	H3	15m ⁽²⁾	
Difference in height between indoor units connected to the same CH box branch	H4	≤ 4m	≤ 4m
Height difference between CH boxes	H5	≤ 15m	≤ 15m
Difference in height between the outdoor units	H6	≤ 0.1m	≤ 0.1m

(*) See the technical manual for the recommended number of indoor units (TC). ⁽¹⁾ Longer piping (up to 110 m) is available for all models. Remember, you must obtain prior approval from Hitachi's Customer Service team if the difference in height is greater than 50 m. Please contact Hitachi's Customer Service department to provide them with the necessary features of the system so that they can carry out a feasibility study. ⁽²⁾ The recommended height difference between the CH box and the indoor unit must be no more than 15 m. If the height difference is greater, it could compromise the operating performance. ⁽³⁾ If following the recommended number of indoor units, the total length of piping must be less than 1,000 m due to the additional coolant load limit. If you exceed the recommended number of indoor units, the restrictions for the total length of the pipes apply.

2-pipe diagram

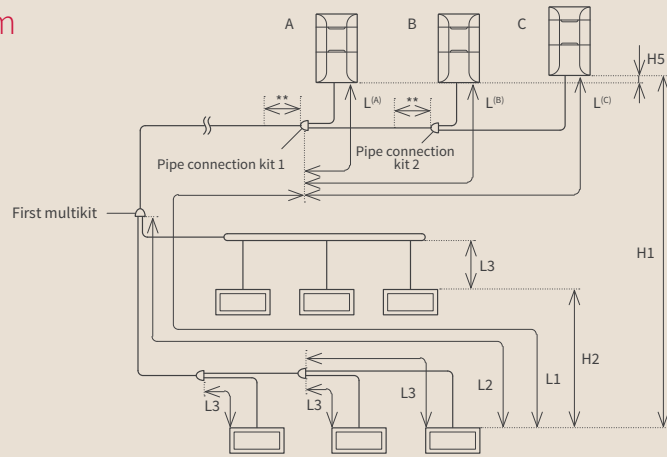

3-pipe diagram

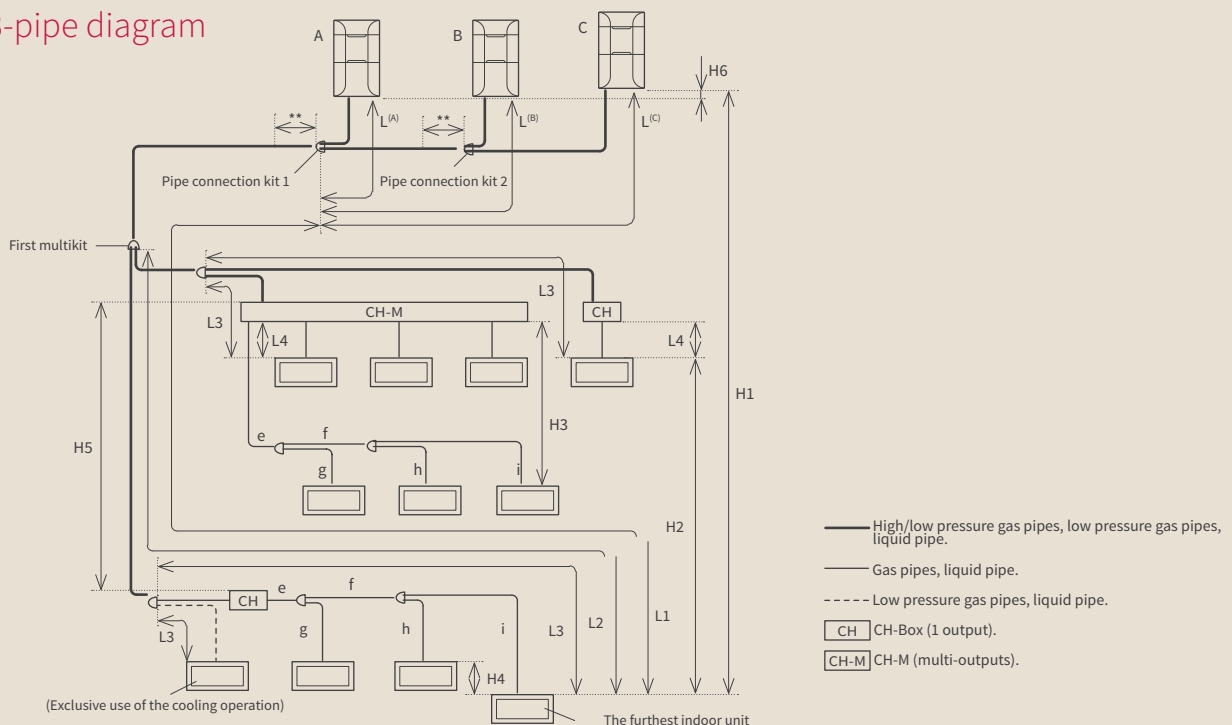

* These maximum values may vary depending on the maximum number of indoor units connected. Refer to current technical documentation.
 ** Keep a straight distance of 500 mm or more downstream of the connection kit.



VRF IVX Centrifugal



Ideal solution for city centers

Installed in suspended ceilings, units are invisible from the outside. Perfect for retail units and buildings in areas with restrictive local planning regulations such as listed buildings.

Easy to position

Suspended single-block system: less footprint. Air intake and air outlet can be adjusted to suit the site's needs (same side or at right angle). Available static pressure up to 120 Pa. The air intake and outlet grilles are also interchangeable, increasing your installation options in any part of the building. No need to obtain permits to shut the road for a crane lift.

More comfort

The IVX Centrifugal VRF can provide air-conditioning for up to 6 different zones, all of which can be individually controlled depending on the needs of the occupants. The premium compressor installed on these units provides smart defrosting. This lengthens the heating period and ensures a more comfortable environment.

Silent

Fans are equipped with a variable frequency driver, which achieves sound levels unmatched on the market.

Compatible with all SYSTEM FREE indoors and controls:

From individual hard wired controls to central controls and communication interfaces for direct integration into a BMS.

Installation

You can opt for 2 branches with up to 4 indoor units or up to 6 indoor units on one single line. Connect up to a maximum of 5 different indoor units for RASC-(4-6)HNPE or 6 indoor units for RASC-(8/10) HNPE. Also compatible with DX KIT.

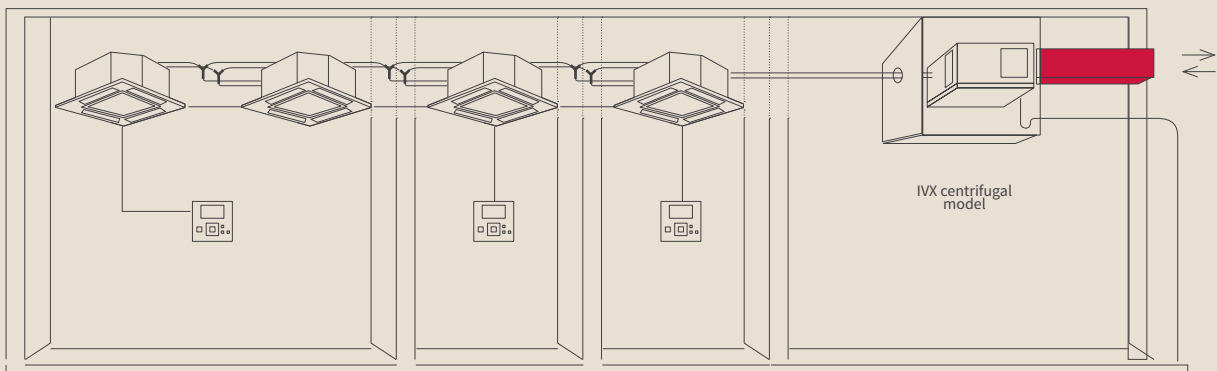

Outdoor units

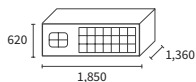
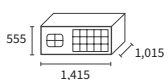

RASC-4HNPE
RASC-5HNPE
RASC-6HNPE

RASC-8HNPE
RASC-10HNPE

Performance, cooling	Unit	RASC-4HNPE	RASC-5HNPE	RASC-6HNPE	RASC-8HNPE	RASC-10HNPE
Nominal Cooling capacity	kW	10.00	12.50	14.00	20.00	24.00
Rated power input cooling	kW	2.99	3.98	5.09	7.41	9.02
EER	-	3.35	3.14	2.75	2.7	2.66
SEER (average climate) *	-	5.6	5.43	5.22	5.39	5.48
Seasonal energy class	-	A				
Working range in Cooling mode	°C	-5°C / +46°C (DB)				

Performance, heating

Nominal Heating capacity	kW	11.20	14.00	15.50	22.40	26.00
Rated power input heating	kW	2.95	4.12	5.74	7.00	8.52
COP	-	3.8	3.4	2.7	3.2	3.05
SCOP (average climate) *	-	3.98	3.74	3.66	3.51	3.71
Seasonal energy class	-	A				
Working range in Heating mode	°C	-15°C / +15.5°C (WB)				

Technical features

Airflow (cooling)	m ³ /h	3300	3600		6900	
Available static pressure (rated / max.)	Pa	56 / 90	72 / 100	100 / 100	84 / 120	102 / 120
Sound power	dB(A)	70	71	72	74	75
Sound pressure in Cooling mode (night mode)	dB(A)	52 (48)		53 (49)	55 (51)	56 (52)
Net weight	kg	192		300		303
Dimensions (H x L x D)	mm	555 x 1415 x 1015			620 x 1850 x 1360	
Diameter of pipes (Liq / Gas)	inches	3/8 - 5/8			3/8 - 1 1/8	1/2 - 1 1/8
Compressor	-	SCROLL				
Grille dimension (air intake)	-	444 x 642			509 x 925	
Grille dimension (air outlet)	-	288 x 334			337 x 398	
Min. power of indoor unit	Hp	0.8				
Number of connectible units (min - max)	-	1 - 5			1 - 6	

Refrigeration characteristics

Refrigerant	-	R410A				
Initial refrigerant charge	kg	4.1	4.2		5.7	6.2
Max. length / Additional charge	m/g/m	75 / see technical documentation			100 / see technical documentation	
Pre-charged for	m	30				
Max. level difference (outdoor unit above)	m	30 / 20				

Electrical features

Power supply	-	400V / 3 Ph + N / 50Hz				
Max. current	A	14.1		16.0	24.7	
Recommended fuse size	A	20			32	
Cable width (EN 60 335-1) ⁽¹⁾	mm ²	5 x 4.00			5 x 6.00	
Indoor/outdoor connection (shielded)	mm ²	2 x 0.75				

⁽¹⁾ Data shown is for indication purposes only. It is the installer's responsibility to ensure that these cable widths meet the needs of the facility and current standards.

* The RASC-4HNPE, follows EcoDesign ErP Lot10. Its seasonal performance follows standard EN14825 (2013). HITACHI Centrifugal units are VRF-certified, so the specified performance applies for units only.

Controls and compatible accessories (see the tab VRF TWIN controls)

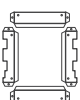

Fan duct accessory for optional air outlet position
FD-RASC46
FD-RASC810



Multi kit
See next page

Installation rules

VRF IVX Centrifugal

Quantity of indoor units

External unit	Hp	4	5	6	8	10
Max. number of indoor units			5			6
Min. power of indoor unit					0.8	

Permitted connection ratio

External unit	Hp	4	5	6	8	10
Max. number of indoor units	1 to 4	75~120%				
		3 to 4.8 Hp	3.8 to 6 Hp	4.5 to 7.2	6 to 9.6 Hp	7.5 to 12 Hp
	5	75~100%				
		3 to 4 Hp	3.8 to 5 Hp	4.5 to 6 Hp	6 to 8 Hp	7.5 to 10 Hp
	6	75~100%				
		-	-		6 to 8 Hp	7.5 to 10 Hp

* If more than 4 indoor units are connected, the power of the indoor units must be balanced out according to the table below.

Authorized combinations of indoor units for all outdoor units

The most powerful unit in the combination	0.80	1.00	1.30	1.50	1.80	2.00	2.30	2.50	3.00	4.00	5.00	6.00
The least powerful unit in the combination	0.80					1.00			1.30	1.50	1.80	2.00

RASC-10HNPE: Special combinations allowed for the outdoor unit

	Power combinations of authorized indoor units (Hp)					
Max. number of indoor units	2	8 + 3	8 + 2	10 + 3	10 + 2	-
	3	8 + 2 + 2	8 + 1.5 + 1.5	8 + 1 + 1	10 + 1.5 + 1.5	10 + 1 + 1

4 to 10 Hp units: Permitted installation (1 to 6 indoor units)

- Line branch installation.
- 1 or 2 lines with a constant diameter.
- Installation with more than 4 indoor units: branch connections off one main permitted line (2 branches not allowed).

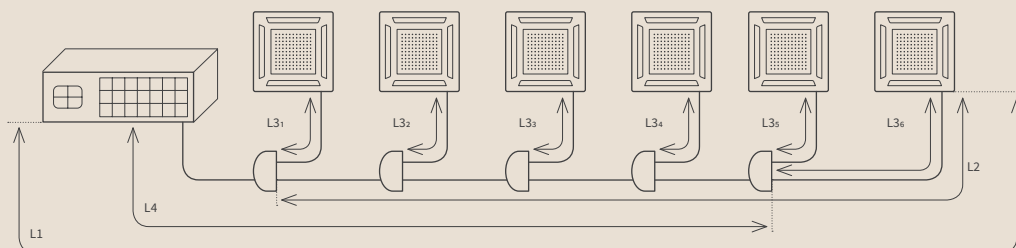

Design rules for refrigeration piping

External unit		Hp	4	5	6	8	10
Max. length between outdoor unit and the furthest indoor unit	Actual length	m		75			100
	Equivalent length	m		95			125
Max. level difference from outdoor unit to indoor unit (H) (outdoor unit above/below)		m			30/20		
Max. level difference from indoor unit to indoor unit		m			10		
Max. level difference from Multikit to indoor unit / Multikit to Multikit		m			3		
Total length of the pipe		m		95		100	145
Max. length of indoor unit to Multikit		m		10			15
Max. length of first Multikit to furthest indoor unit		m		30			40

Multikit part numbers		Hp	E-102SN4	E-162SN4
Diameter of the main line			-	Constant diameter
Diameter of outdoor unit - first multikit	Liq/Gas	inches	3/8 - 5/8	3/8* - 1 1/8 1/2 - 1 1/8

**If the pipe is longer than 70m, use a 1/2" liquid line instead of 3/8".

Power of indoor unit		Hp	< 1.5	1.8 to 2	2.3 to 6	8	10
Diameter of multikit - indoor unit	Liq/Gas	inches	1/4 - 1/2	1/4 - 5/8	3/8 - 5/8	3/8 - 3/4	3/8 - 7/8

