



# IC 912 LX Pt100-TC

electronic controller with single output

## USER INTERFACE

The user has a display and four keys for controlling status and programming of the instrument.

### KEYS AND MENUS

UP key		Scrolls through the menu items Increases the values Can be set by parameter (par. H31)
DOWN key		Scrolls through the menu items Decreases the values Can be set by parameter (par. H32)
fnc key		ESC function (exit) Can be set by parameter (par. H33)
set key		Accesses the setpoint Accesses the menus Activates the functions* Confirms the commands Displays the alarms (if active)

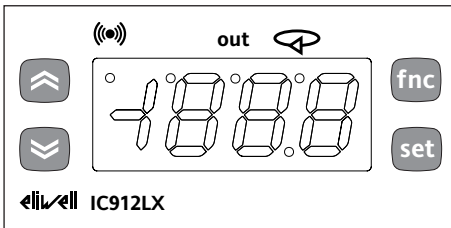

At start-up the instrument performs a Lamp Test; for five (5) seconds the display and the leds blink, in order to verify their integrity and correct operation; afterwards it will appear the label "Lod" (Loading) for ten (10) seconds. The instrument has two main menus: the "Machine Status" and "Programming" menu.

### ACCESSING AND USING MENUS

Resources are arranged in a menu, which can be accessed by pressing and quickly releasing the "set" key ("Machine Status" menu) or by holding down the "set" key for more than 5 seconds ("Programming" menu).

To access the contents of each folder, indicated by the relevant label, just press the

"set" key once.

You can now scroll through the contents of each folder, modify it or use its functions. If you do not use the keyboard for over 15 seconds (time-out) or if you press the "fnc" key once, the last value shown on the display is confirmed and you return to the previous screen mask.

### MACHINE STATUS MENU

#### (See Machine Status Menu Diagram)

To access the "Machine Status" menu press and quickly release the "set" key. The label "SP1" appears.

By using the "UP" and "DOWN" keys you can scroll through the other folders in the menu:

- AL: alarm folder (if alarms present, except for faulty probe/probe error;
- SP1: Setpoint 1 setting folder.

#### Setpoint 1 Setting

Access the "Machine Status" menu by pressing and quickly releasing the "set" key. The label of the "SP1" folder appears. To display the Setpoint 1 value press the "set" key again.

The value appears on the display.

To change the Setpoint 1 value, use the "UP" and "DOWN" keys within 15 seconds.

If the parameter is LOC = y the Setpoint cannot be changed.

#### Alarm on

If an alarm condition exists, when accessing the "Machine Status" menu the "AL" folder label appears (see the "Diagnostics" section).

### PROGRAMMING MENU

#### (See Programming Menu Diagram)

##### 1) Level 1 Parameters

To access the "Programming" menu, press the "set" key for more than 5 seconds. If specified, the level 1 access PASSWORD will be requested (see parameter "PA1") and (if the password is correct) the label of the first folder will follow. If the password is wrong, the display will show the PA1 label again.

To scroll other folders, use the "UP" and "DOWN" keys; **the folders contain only the level 1 parameters.**

**NOTE: At this point level 2 parameters are NOT visible, even if they aren't protected by password.**

##### 2) Level 2 Parameters

In the Programming Menu go into the "CnF" folder, scroll all the parameter until you reach the PA2 label. By pressing and releasing the "set" button you will enter to level 2 parameters and the label of the first folder in the programming menu will follow.

The level 2 parameters may be protected by a second password (see "PA2" parameter inside "diS" folder, not to be confused with PA2 label inside "CnF" folder.

If specified, level 2 parameters are hidden to user; accessing the "CnF" folder the level 2 access PASSWORD will be requested and (if the correct password is entered) the label of the first folder in the programming menu will follow.

**NOTE: At this point you will see only level 2 parameters.**

Level 1 parameters will NOT be visible; to reach them you shall exit the Programming Menu and re-entry the Programming Menu section (see step 1). To enter the folder, press "set". The label of the first visible parameter appears. To scroll through the other parameters, use the "UP" and "DOWN" keys; to change the parameter, press and release "set", then set the desired value using the "UP" and "DOWN" keys, and confirm with the "set" key. Move to the next parameter.

**PLEASE NOTE:** It is suggested to switch-off and switch-on again the instrument everytime it is changed the configuration of the parameters: this prevents malfunctioning on regulation and delay time occurring.

#### \*FOLDER FUNCTIONS Fnc

**Inside Fnc folder (last folder visible from Programming Menu, level 1) there are available the following functions: (enable them with the "set" button).**

### LED

Position	Related Function	Status
out	Relay 1 (OUT)	ON for relay on; blinking for delay, locked protection or activation
	Alarm	ON when the alarm is enabled; blinking when the alarm is silenced
	Soft Start (and Setpoint setting)	ON when setting Setpoint; <b>blinking</b> when Soft Start is enabled;

Function	Label function	Label function
	ENABLED	DISABLED
Soft Start	SoN	SoF**
Reduced Set	OSP	SP**
Activation stopped	bon**	boF
Stand-by	on**	oF
Maintenance required	Atn	AtF**

**NOTE: In this case the label UnP will be shown (blinking)**  
\*\*default

When you turn Off the instrument all labels return to default status

### PASSWORD

The passwords "PA1" and "PA2" allow access respectively to level 1 and level 2 parameters. In the standard configuration passwords are not present. To enable them (value ≠ 0) and assign them the desired value, access the "Programming" menu, within the folder with the "diS" label. If passwords are enabled, they will be requested:

- PA1 at the entrance of the "Programming" menu (see the "Programming Menu" section);
- PA2 within the folder with the "Cnf" label containing level 1 parameters.

### COPY CARD

The Copy Card is an accessory connected to the TTL serial port which allows programming quickly the instrument parameters (upload and download parameter's map). The operation is performed as follows:

#### Format

This command allows Copy Card formatting, an operation necessary in case of first use or to copy maps with different models. Warning: if the Copy Card has been programmed, using the "Fr" the data entered are erased. This operation cannot be cancelled.

#### Upload

This operation loads the programming parameters from the instrument.

#### Download

This operation downloads to the instrument the programming parameters.

#### NOTE:

- **UPLOAD: instrument --> Copy Card**
- **DOWNLOAD: Copy Card --> instrument.**

The operations are performed accessing the folder identified by the "FPr" label and selecting, according to the case, "UL", "dL" or "Fr" commands; the operation is confirmed by pressing the "set" key. If the operation is successful an "y" is displayed, on the contrary, if it fails a "n" will be displayed.

#### Download "from reset (instrument OFF"

Connect the Copy Card with the instrument OFF (not under voltage).

When the instrument is switched on the programming parameters will be downloaded into the instrument; after the lamp-test the display will show for about 5 seconds:

- label dLY if copy operation successful
- label DLn if not

#### PLEASE NOTE:

- after the download operation the instrument will immediately work with the new parameters map setting

### KEYBOARD LOCKING

The instrument includes a facility for disabling the keyboard, by programming the "LOC" parameter (see folder with "diS" label). If the keyboard is locked, you can still access the programming menu by pressing the "set" key.

The Setpoint can also be viewed.

### TELEVIS SYSTEM

The TelevisSystem can be connected through TTL serial port (the TTL- RS 485 BUS ADAPTER 130 interface module must be used). To configure the instrument for this purpose you need to access to the folder identified by the "Add" label and to use the "dEA" and "FAA" parameters.

## ADVANCED FUNCTIONS

### SOFT START

**Note: the SOFT START function can be enabled by key or by function.**

The Soft Start regulator permits to set the temperature gradient to reach a defined setpoint in a defined lapse of time.

Through this function, actually, you can obtain a progressive increase of the Setpoint (on which you regulate) from the Ta value (environment Temperature at instruments' start-up) to the real value set on display; this permits to delay the increase of the temperature reducing "overshooting" problems.

Soft Start parameters are visible in the "SOFT START" folder (defined by the "SFt" label)

## DIAGNOSTICS

The alarm condition is always signalled by the buzzer (if present) and by the led of

the alarm icon (🔔)

The alarm signal produced by:

- a regulator probe that measures a value outside probe's range
  - a faulty regulator probe
- is shown as E1 on the instrument display

Probe faults table

DISPLAY	FAULT
E1	Faulty probe 1 (regulator)

**PLEASE NOTE:** In case of wrong connection of the 3rd wire (Pt100 sensor) in "AL" folder it will appear the label "Pt3".

For few seconds the display will show an uncorrect temperature.

When the sensor detects an error condition:

- the code E1 is displayed
- the regulator is activated as indicated by the "On1" and "OF1" parameters if programmed for the duty cycle or:

On1	OF1	Regulator Output
0	0	OFF
0	>0	OFF
>0	0	ON
>0	>0	dc

see Duty Cycle Diagram

### MAXIMUM AND MINIMUM TEMPERATURE ALARM

In case of alarm condition, if alarm exclusion times are not in progress (see, alarm exclusion parameters), the fixed alarm icon is turned on and the relay configured as an alarm is activated. This kind of alarm does not affect the regulation in progress. Alarms are considered as absolute (Abs, default) values or as values related to the Setpoint (rEL, the distance from the Setpoint itself) and based on the Att parameter. In this case (Att=rEL), the HA1 parameter must be set to positive values and the LA1 parameter to negative values. This alarm condition can be viewed in the folder "AL" with the labels "AH1-AL1".

### EXTERNAL ALARM

The device includes the possibility to control an external alarm, from a digital input. If the digital input is active, the alarm control is activated, if programmed, and stays until the next time the digital input is deactivated. The alarm is signaled by turning on the fixed alarm icon, by activating the relay configured as alarm, and by deactivating the other regulators (if specified by the "H11=9" parameter).

This alarm condition can be viewed in the "AL" folder with the label "EA". The relay can be silenced; even if alarm icon starts blinking, controls stay locked until the next time the digital input is deactivated.

Alarms Table

DISPLAY	ALARM
*AH1	High temperature alarm (referred to regulator 1)
*AL1	Low temperature alarm (referred to regulator 1)
EA	External alarm
Opd	Open door alarm

To silence the alarm, press any keys. In this case the LED will blink

\*Alarms are considered as absolute values or as values related to the Setpoint based on the Att parameter.

See Max-Min Alarms Diagram

## INSTALLATION

The instrument is designed for panel mounting. Make a hole of 29x71 mm, insert the instrument and fix it using the brackets provided. Do not mount the instrument in humid and/or dirty places; it is suitable for use in ordinary polluted places. Ventilate the place in proximity to the instrument colling slits.

## ELECTRICAL WIRING

**Attention! Never work on electrical connections when the machine is switched on.**

The instrument is equipped with screw terminal boards for connection of electrical cables with a diameter of 2.5 mm<sup>2</sup> (one conductor only per terminal for power connections).

For the capacity of the terminals, see the label on the instrument.

The relay contacts are voltage free. Do not exceed the maximum current allowed; in case of higher loads, use an appropriate contactor. Make sure the power supply voltage complies with the one required by the instrument.

Probe cables, power supply cables and the TTL serial cables should be distant from power cables.

In 12V versions the power supply however could be cabled with the probe cables and the TTL serial cable.

In 230 V versions the power supply should be cabled with the loads.

Probes can be extended using a regular bipolar cable (note that the extension of the probes affects the EMC electromagnetic compatibility of the instrument: pay extreme attention to wiring).

**NOTE: Pay extreme attention to the probe connection polarity.**

## CONDITIONS OF USE

### PERMITTED USE

For safety reasons the instrument must be installed and used according to the instruction provided and in particular, under normal conditions, parts bearing dangerous voltage levels must not be accessible.

The device must be adequately protected from water and dust as per the application and must also only be accessible via the use of tools (with the exception of the frontlet).

The device is ideally suited for use on household appliances and/or similar refrigeration equipment and has been tested with regard to the aspects concerning European reference standards on safety. It is classified as follows:

- according to its manufacture: as an automatic electronic control device to be incorporated by independent mounting;
- according to its automatic operating features: as a 1 B-type operated control type;
- as a Class A device in relation to the category and structure of the software

### UNPERMITTED USE

Any other use other than that permitted is de facto prohibited. It should be noted that the relay contacts provided are of a practical type and therefore subject to fault. Any protection devices required by product standards or dictated by common sense due to obvious safety reasons should be applied externally.

## LIABILITY AND RESIDUAL RISKS

Invensys Controls Italy S.r.L. shall not be liable for any damages deriving from:

- installation/use other than that prescribed and, in particular, that which does not comply with safety standards anticipated by regulations and/or those given herein;
- use on boards which do not guarantee adequate protection against electric shock, water or dust under the conditions of assembly applied;
- use on boards which allow access to dangerous parts without the use of tools;
- tampering with and/or alteration of the products;
- installation/use on boards that do not comply with the standards and regulations in force.

## TECHNICAL DATA

Frontal panel protection: IP65.

Casing: plastic body in resin type PC+ABS UL94 V-0, inspection window in polycarbonate, buttons in thermoplastic resin.

Dimensions: frontal panel 74x32 mm, depth 59 mm (without wirings).

Installation: on panel, with drilling template 71x29 mm (+0.2/-0.1 mm).

Use temperature: -5...55 °C.

Storage temperature: -30...85 °C.

Use environment humidity: 10...90 % RH (not condensing).

Storage environment humidity: 10...90% RH (not condensing).

Viewing range:

- Pt100 model : -150...650°C, with decimal point, selectable through parameter ndt

- TcJ model -40...750°C\*

- TcK model -40...1350°C\*

\*without decimal point

on 3 digit & 1/2 mark display.

**PLEASE NOTE: viewing is 1/10 °C for model Pt100 and 1°C for models TcJ/TcK**  
Serial: TTL for connection to Copy Card and TelevisSystem.

Analogue input: one PT100 input or TcJ or TcK depending on model.

Digital inputs: 1 voltage-free digital input.

Digital output: 1 SPDT output on 8(3)A 1/2 hp configurable. (for relay capabilities see label on the instrument)

Buzzer output: only on models with Buzzer.

Measuring range: from -150 to 1350.

Accuracy:

- Pt100 model : 0,5% for all scale + 1 digit; 0,2% from -150 to 300°C.

- TcJ model: 0,4% for all scale + 1 digit;

- TcK model 0,5% for all scale + 1 digit; 0,3% from -40 to 800°C.

Resolution:

- Pt100 model: 0,1°C (0,1°F) within 199,9 °C, 1°C (1°F) over

- TcJ/TcK model 1°C (1°F).

Consumption:

- model 230V: 3 VA max.

- model 12/24V: 1,5 VA max.

Power supply: 12/24 V~/± ±10% or 230V~ ±10% 50/60 Hz.

Warning: check the power supply specified on the instrument label; for relay and power supply capacities, contact the Sales Office).

**PLEASE NOTE: The technical data included in this document, related to measurement (range, accuracy, resolution, etc.) refer to the instrument itself, and not to its equipment such as, for example, sensors. This means, for example, that sensor(s) error(s) shall be added to the instrument's one.**

### Duty Cycle Diagram

parameters On1 ed OF1 programmed for the duty cycle

On1	OF1	regulator output
0	0	OFF
0	>0	OFF
>0	0	ON
>0	>0	dc

When the analogue input detects an error condition:

- the code E1 is displayed
- the regulator is activated as indicated by the "On1" and "OF1" parameters if programmed for the duty cycle

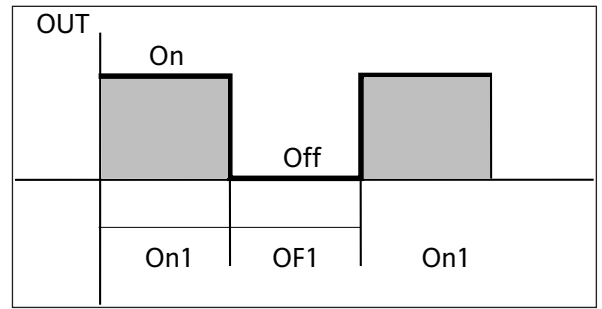

### ON-OFF Regulation Diagram

HC1 Heat/Cool Mode.  
SP1 Setpoint 1.  
dF1 diFFferential. Relay 1 tripping differential.

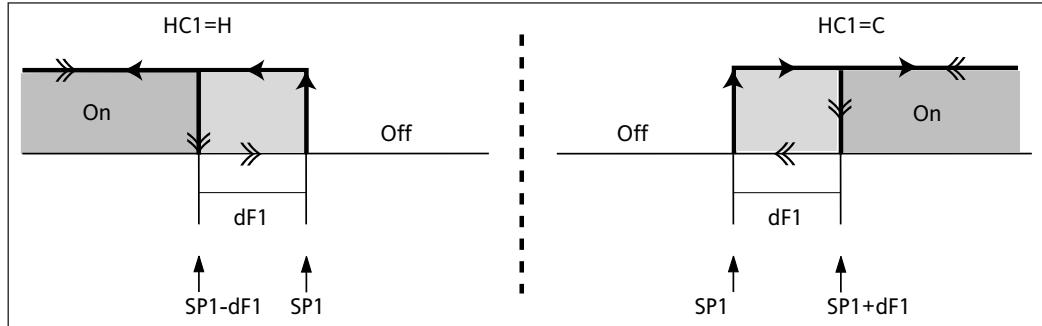

### Max/Min. Alarms Diagram (Maximum and Minimum Temperature Alarms)

The maximum alarm will become when the probe temperature will be:

- higher o equal to HA1 if Att=Abs(olute)
- higher o equal set + HA1 if Att=rEL(ative)

- if Att=Abs(olute) HA1 should be with sign;
- if Att=rEL(ative) HA1 should be only positive

The minimum alarm will become when the probe temperature will be::

- lower or equal to LA1 if Att=Ab(solute)
- lower or equal to set + LA1 if Att=rEL(ative)

- se Att=Ab(solute) LA1 should be with sign;
- se Att=rEL(ative) LA1 should be only positive

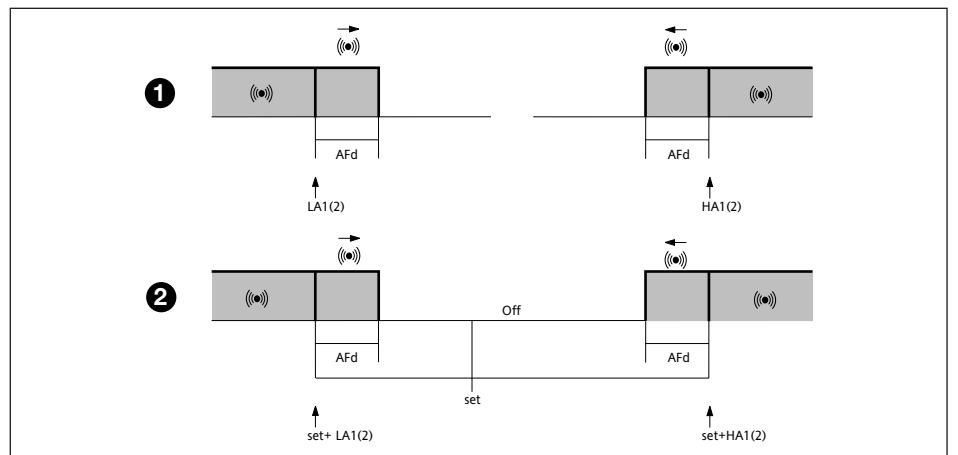

The maximum alarm will ends when the probe temperature will be:

- lower or equal to HA1 - AFd if Att=Abs(olute)
- lower or equal to set + HA1 - AFd if Att=rEL(ative)

The minimum alarm will ends when the probe temperature will be:

- higher o equal a LA1 + AFd if Att=Abs(olute)
- higher o equal a set + LA1 + AFd if Att=rEL(ative)

**\*\*NOTE: At level 1 the folders will show only level 1 parameters. At level 2 the folders will show only level 2 parameters.**

Tab. 1 Parameter Table

PAR.	DESCRIPTION	RANGE	DEFAULT*	VALUE**	LEVEL**	U.M.
<b>REGULATOR 1 (folder with "rE1" label)</b>						
HC1	Heat/Cool Mode. If set to H the generic regulator actuates for hot operation. If set to C the generic regulator actuates for cold operation	H/C	H/C*		1	flag
OS1	Offset Setpoint 1 <b>see ON-OFF regulation diagram</b>	-30.0...30.0	0		2	°C/°F
db1	Operating Range 2 <b>see ON-OFF regulation diagram</b>	0...30.0	1*		1	°C/°F
dF1	differential. Relay 1 tripping differential. The regulator stops on reaching the Setpoint value (as indicated by the adjustment probe), and restarts at temperature value equal to the Setpoint 1 plus (o minus depending on HC1) the value of the differential. <b>see ON-OFF regulation diagram</b>	0.0...30.0	0 (n.z. models)* 1*		1	°C/°F
HS1	Higher SET. Maximum possible setpoint 1 value.	LS1..HdL	*		1	°C/°F
LS1	Lower SET. Minimum possible setpoint 1 value.	LdL..HS1	*		1	°C/°F
HA1	Maximum Alarm OUT <b>See Max/Min. Alarm Diagram</b>	LA1...1999	*		1	°C/°F
LA1	Maximum Alarm OUT <b>See Max/Min. Alarm Diagram</b>	-328.0...HA1	*		1	°C/°F
<b>REGULATOR 1 PROTECTIVE DEVICE (folder with "rE1" label)</b>						
dn1	Delay time in activating the regulator relay after switch-on of instrument.	0...250	1		1	°C/°F
do1	Delay after switch off. The indicated time must elapse between switch-off of the regulator relay and the successive switch-on.	0...250	0		1	sec
di1	Delay between switch-ons. The indicated time must elapse between two successive switch-ons of the regulator.	0...250	0		1	min
dE1	Delay before switch-off. The indicated time must elapse between switch-off request and the switch-off of the regulator.	0...250	0		1	min
<b>PLEASE NOTE: for parameters dn1, do1, di1, dE1 0= not active</b>						
On1	On time (regulator 1). Regulator activation time in the event of faulty probe. If set to "1" with OF1 at "0" the regulator is always on, while at OF1 >0 it functions always in duty cycle mode. <b>see Duty Cycle diagram</b>	0...250	0		1	sec
OF1	OFF time (regulator 1). Regulator in disabled state time in the event of a faulty probe. If set to "1" with On1 at "0" the regulator is always off, while at On1 >0 it functions always in duty cycle mode. <b>see DC diagr.</b>	0...250	1		1	min
<b>SOFT START (folder with label "Sft")</b>						
dSi	dynamic Step increment (Step Value). Value (°C/°F) of every incremental step (dynamic) of the regulation (set)point. 0=disable SOFT START function.	0...25.0 (0...twentyfive.0)	0		2	°C/°F
dSt	dynamic Step time (Step Duration). Delay time between two steps (dynamic) of the regulation (set)point	0...250	0		2	H/m/sec
Unt	U.M (hours, minuts, seconds)	0/1/2	1		2	H/m/sec
SEn	Outputs enabled. Define on which output the function should be enabled: 0 = function disabled; 1 = OUT 1; 2,3 = not used	0/1/2/3	0		2	num
Sdi	Function Threshold re-entry . Define the threshold, over which there is the automatic re-entry of the SOFT START function	0...30.0	0		2	°C/°F
<b>ALARMS (folder with "AL" label)</b>						
Att	Alarm type. Parameter "HA1" and "LA1" modes, as temperature absolute values or as differential compared to the Setpoint. 0 = absolute value; 1 = relative value.	Abs/reL	Abs		2	flag
Afd	Alarm Fan differential. Alarm differential.	1.0...50.0	2.0		2	°C/°F
PAO (!)	Power-on Alarm Override. Alarm exclusion time after instrument (8) switch on, after a power failure.	0...10	0		1	hours
SAO	Setpoint Alarm Override. Exclusion alarm time until Setpoint is reached. 0 = disabled. If >0, an alarm occurs, if setpoint has not been reached after the time (hours) set by this parameter.	0...10	0		1	hours
tAO (8)	temperature Alarm Override. Temperature alarm signal delay time.	0...250	0		1	min
<b>COMMUNICATION (folder with "Add" label)</b>						
dEA (!)	dEvice Address. Device address: indicates the appliance address to the management protocol. dEvice Address.	0...14	0		1	num
FAA (!)	Family Address: indicates the appliance family to the management protocol.	0...14	0		1	num
<b>DISPLAY (folder with "dis" label)</b>						
LOC	(keyboard) LOCK (set and keys). Keyboard locking. However, you can enter parameter programming modify them along with the status of this parameter in order to allow keyboard locking. y = yes; n = no	n/y	n		1	flag
PA1	PAssword 1. When enabled (value other than 0) it constitutes the access key for level 1 parameters.	0...250	0		1	num
PA2****	PAssword 2. When enabled (value different from 0) it represents the access key for level 2 parameters.	0...250	0		2	num
ndt	number display type. View with decimal point. y = yes; n = no <b>PLEASE NOTE: for modelsTcJ/TcK only n value.</b>	n/y	n		1	flag
CA1	CAlibration 1. Calibration 1. Positive or negative temperature value added to the value read by probe 1,	-30.0...30.0	0		1	°C/°F
CAI	CAlibration Intervention. Intervention on view offset, thermostat offset or both. 0 = modifies the temperature displayed only; 1 = adds to the temperature used by regulators, not to the temperature displayed, which stays unchanged; 2 = adds to the temperature displayed that is also used by regulators.	0/1/2	2		2	num
LdL	Low display Label. Minimum value the instrument is able to display.	-328.0...HdL	*		2	°C/°F
HdL	High display Label. Maximum value the instrument is able to display.	LdL...1999	*		2	°C/°F
dro	display read-out. Select °C or °F for displaying the temperature read by the probe. <b>PLEASE NOTE: the switch between °C and °F DO NOT modify setpoint, differential, etc. (for example set=10°C become 10°F).</b>	°C/°F	°C		1	flag

PAR.	DESCRIPTION	RANGE	DEFAULT*	VALUE**	LEVEL**	U.M.
<b>CONFIGURATION (folder with "CnF" label)</b>						
H00(1)(!)	<b>PLEASE NOTE: PARAMETER VISIBLE ONLY INTc/TcK MODELS</b> Probe type selection: Pt1 for Pt100; JtC: for Tcj; HtC for Tck	Pt1/JtC/HtC	Pt1/JtC/HtC*		1	num
H02	Time to enable keys, if these are configured for a specific function. For ESC, UP and DOWN keys configured for specific function (defrost, aux, etc) it set the elapsed time for the manual activation of the related function. aux function has a fixed time of 1 second	0..15	5		2	sec
H05	Window Filter. -2=very fast; -1=fast; 0=normal; =slow; 2=very slow	-2/+1/0/1/2	0		2	°C/°F
H06	key/input aux/door switch light active when instrument is off (but under tension)	n/y	y		2	flag
H08	Stand-by operating mode. 0=display switch off; 1= display on and loads stopped; 21= display off and loads stopped;	0/1/2	2		2	num
H10	Delay outputs from power-on. WARNING! If set = 0 it is not active; if set ≠0 output will not be activated before this time	0..250	0		1	min
H11	Configuring digital inputs. 0 = disabled; 1 = SOFT START; 2 = Offset Setpoint; 3 = outputs stopped; 4 = not used; 5 = auxiliary output; 6 = stand-by 7 = maintenance requested 8 = external alarm 9 = external alarm stop regulators	0..9	0		2	num
H13	Polarity and Priority Digital Input no= normally open/ nc= normally closed / noP= normally open with Polarity / ncP= normally close with Polarity	no/nc/noP/ncP	no		2	num
H14	Delay Activation Digital Input	0..250	0		2	num
H31 (!)	Configurability UP key. 0 = disabled; 1 = SOFT START; 2 = Offset Setpoint; 3 = outputs stopped; 4 = not used; 5 = auxiliary output; 6 = stand-by 7 = maintenance requested	0..7	0		2	num
H32 (!)	Configurability DOWN key. Same as H31.	0..7	0		2	num
H33 (!)	Configurability ESC key. Same as H31. ( 2 = Offset Setpoint; default)	0..7	0		2	num
rEL	release firmware. Device version: read only parameter.	/	/		1	/
tAb	tAble of parameters. Reserved: read only parameter.	/	/		1	/
<b>COPY CARD (folder with "Fpr" label)</b>						
UL	Up load. Programming parameter transfer from instrument to	/	/		1	/

**label PA2**

Inside CnF folder it is possible to reach all level 2 parameters from label PA2 by pressing the "set" button  
SEE 2) level 2 Parameters paragraph

Copy Card.						
dL	Down load. Programming parameter transfer from Copy Card to instrument	/	/		1	/
Fr	Format. Erasing all data in the copy card. <b>PLEASE NOTE using "Fr" parameter (copy card formatting) the data within the copy card will be lost permanently. The operation cannot be cancelled. After using the copy Card device the controller must be switch off and switch on again</b>	/	/		2	/
<b>FUNCTIONS (folder with label "FnC")</b>						
Inside FnC folder (last visible folder from Programming Menu) there are available some functions that could be enabled by "set" button SEE FUNCTIONS paragraph						

(1) **PARAMETER VISIBLE ONLY INTc/TcK MODELS. Pt100 Model works only with Pt100 sensor (3 wires) while Tcj and TcK Models work also with Pt100 sensor selectable by this parameter**

(2) Positive values: active input when the contact is closed; negative values: 1= Active when contact is open

(5) If alarm are relative, the HAL parameter must be set to positive values and the LAL parameter to negative values

(8) Referred exclusively to high and low temperature alarms

\* **DEFAULT column: for parameters highlighted with \* default value depending on model.**

\*\* **VALUE column: to be filled manually, with custom settings (if different from the default value).**

\*\*\* **LEVEL column: indicates the level of visibility for parameter that can be accessed by a PASSWORD (see the related paragraph)**

\*\*\*\* **PA2 is visible (it will be requested, if specified) at level 1 in CnF folder and can be set (it can be modified) at level 2 in diS folder**

**(!) WARNING!**

- If one or more of these parameters highlighted with (!) are modified, the controller must be switched off and switched on again to ensure correct operation.
- It is strongly recommended, anyway to switch off and switch on again the controller anytime parameters have been changed to prevent malfunctioning on configuration and/or ongoing timings

# Programming Menu Diagram

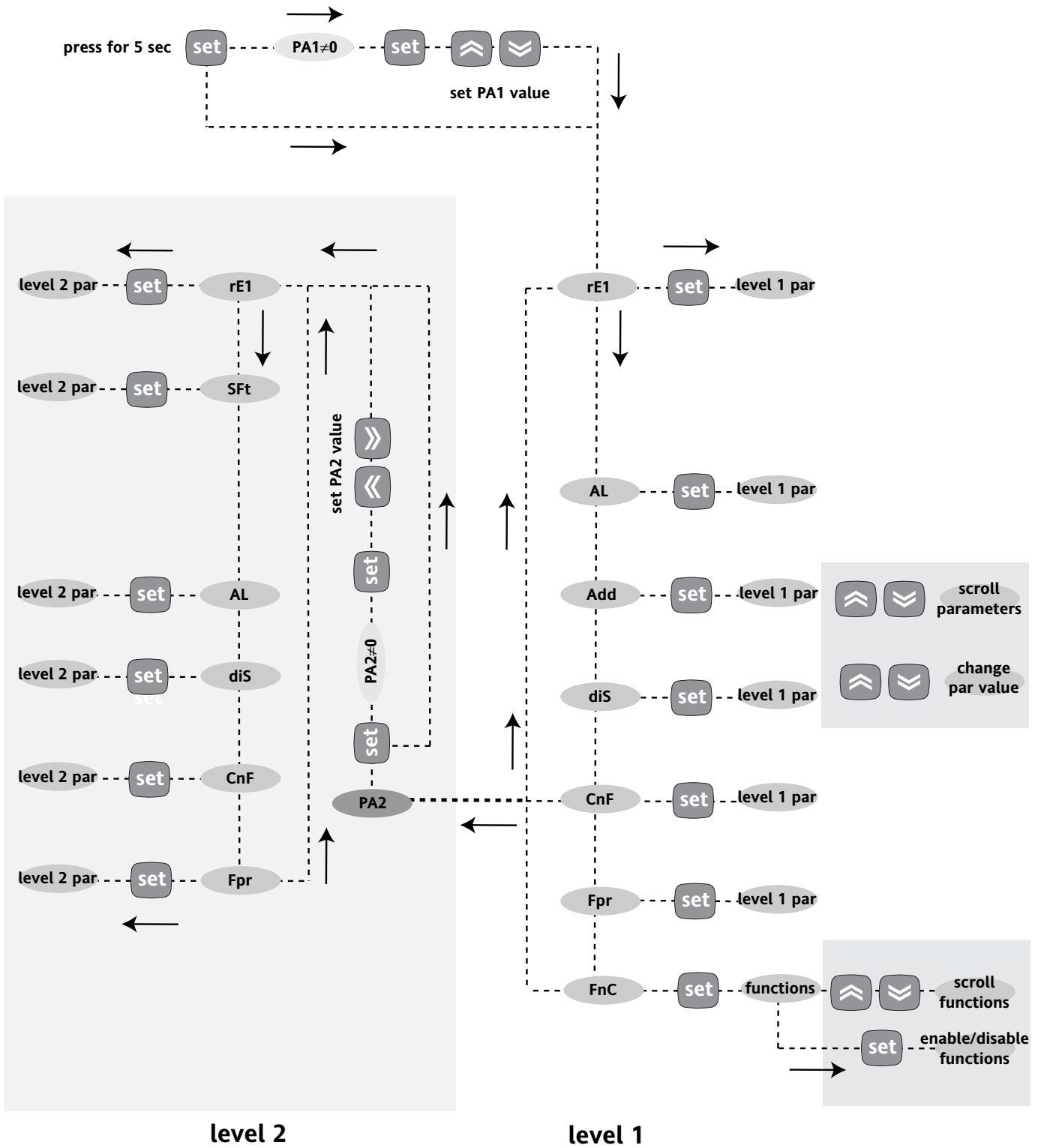

**PARAMETERS**

Level 1 folders	Level 2 folders
rE1	rE1
AL	AL
Add	
diS	diS
CnF	CnF
Fpr	Fpr

**FUNCTIONS**

FnC
-----

## Status Machine Diagram

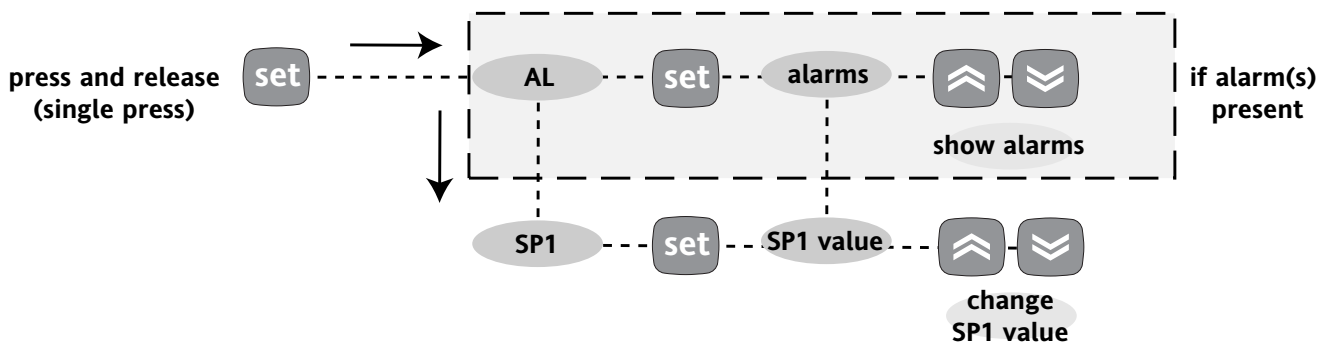

## Wiring diagram

### WIRING (12V and 230V supply)

1 - 2	N.O. regulator relay output (OUT1)
1 - 3	N.C. regulator relay output (OUT1)
6 - 7	Power supply 1,5 VA max. (12V version) Power supply 3 VA max. (230V version)
8 - 9	Digital Input (D.I.)
*10-11-12	Pt100 3 wires input
*11-12	Tc/TcK input
A	TTL input for Copy Card and TelevisSystem

### PLEASE NOTE:

- User Default Settings
  - for relay capacities check on the instrument label
- In the diagram there are shown only 12V and 230V supply and relays with 8(3) 1/2 hp 250V capability
- **Pay extreme attention to the probe connection polarity.**

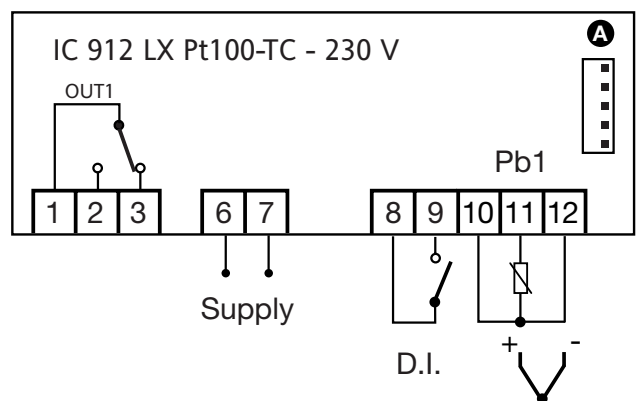
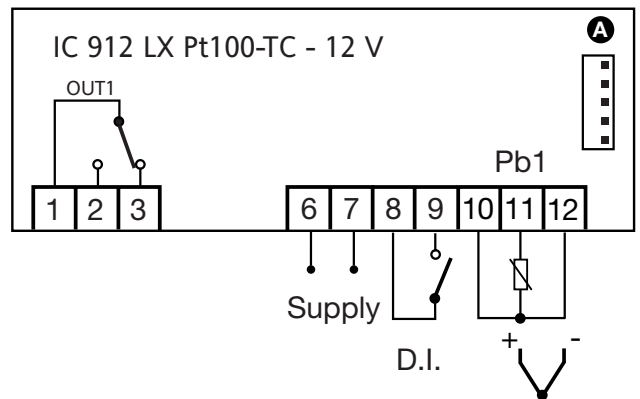

**Invensys Controls Italy s.r.l**  
 via dell'Industria, 15 Zona Industriale Paludi  
 32010 Pieve d'Alpago (BL) ITALY  
 Telephone +39 0437 986111  
 Facsimile +39 0437 989066  
 Internet <http://www.climate-eu.invensys.com>

## DISCLAIMER

This manual and its contents remain the sole property of Invensys Controls Italy s.r.l., and shall not be reproduced or distributed without authorization. Although great care has been exercised in the preparation of this document, Invensys Controls Italy s.r.l., its employees or its vendors, cannot accept any liability whatsoever connected with its use. Invensys Controls Italy s.r.l. reserves the right to make any changes or improvements without prior notice.