



HAWCO in association with SYLVANIA are pleased to announce the launch of the SKORPION process air heater.

Fast, accurate and versatile, the SKORPION provides hot air up to 760°C, easily controlled via the on-board precise temperature controller.

SKORPION™

Process Air Heater



All-IN-ONE HEATER
complete heating solution in one unit

The new SKORPION Process Air Heater from OSRAM SYLVANIA represents the perfect combination of power, size, reliability and control in Air Heating technology.

Whether your process involves drying, curing, melting, or sealing, the SKORPION gives you full closed-loop PID temperature regulation from 0° to 1400°F (760°C) with $\pm 2^\circ\text{C}$ accuracy.

In addition, the SKORPION's all-metal air source is powerful and robust, ensuring reliable operation in dusty environments, with an adjustable air damper for flow control.

The SKORPION package is complete with OSRAM SYLVANIA's patented long-life Serpentine heater elements, and a robust over-temperature safety system.

Features

- Maximum air temperature 1400°F (760°C)
- Temperature accuracy $\pm 2^\circ\text{C}$
- Maximum flow rate 10 SCFM
- Temp Control 1/32 DIN
- Power Control 50A Solid State Relay
- Blower ON switch
- Heater ON switch

EX-STOCK ONLY
£599
including VAT, Delivery and FREE High Flow Nozzle

Hawco

The Wharf, Abbey Mill Business Park,
Lower Eashing, Godalming, Surrey GU7 2QN

OSRAM SYLVANIA



F075616
SKORPION™ Air Heater
3.0kW 240V 1PH 12.5A

Unit comprises:

- Element
- Air supply
- Temperature controller
- Temperature sensor

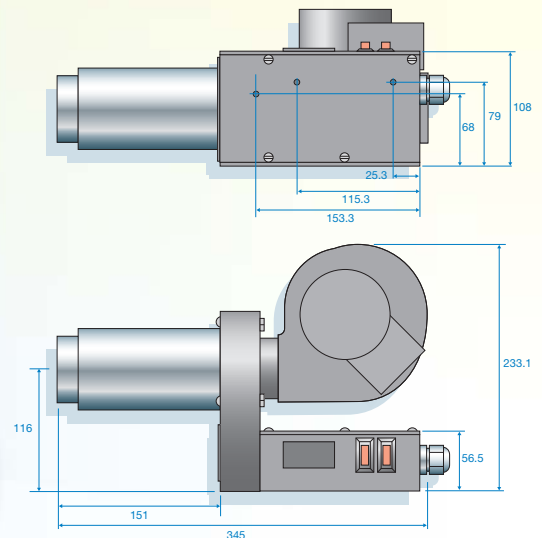

Call 01483 869080 www.hawco.co.uk



Total Engineering Solutions

HAWCO offer a comprehensive range of products and applications

Thermal & circuit protection products

Heating & temperature control products

Electrical equipment & control devices

Fire detection products

Hawco provide the best in components and instrumentation at the right price, whether you need a simple component, a complete turnkey control system or a custom designed product. Hawco is committed to supplying technical expertise and support that is second to none.

Please do not hesitate to contact us if you would like more information regarding Hawco products and services or to receive our free **QuickPick** range of catalogues.

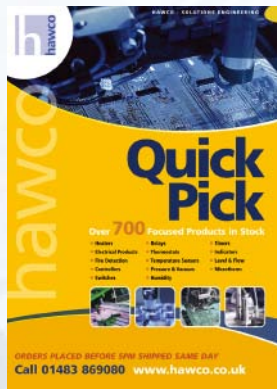

QuickPick catalogue

The ultimate quick reference guide to over 700 spares and maintenance 'on the shelf' products.



Relay products catalogue

All you need for Relay & Control Gear Products to support your pre-production, spares and maintenance needs.



Heating products catalogue

A wide range of heating products that are 'on the shelf' ready for next day delivery.

How to contact us

 **01483 869080**

Fax: 01483 869001

 **info@hawco.co.uk**

For our latest news, brochures, catalogues, datasheets + special offers

visit: www.hawco.co.uk