

USER INTERFACE

The user has a display and four buttons for controlling instrument status and programming.

BUTTONS AND MENUS ACCESSING

UP Button Scrolls through the menu items
Increases the values



DOWN button Scrolls through the menu items
Decreases the values



fnc button ESC function (quit)



Set point button 1-Accesses Machine Status Menu (ACTIVE ALARMS, PROBE READING) and related labels/values;
1-Accesses Programming Menu (PARAMETERS, COPY CARD (LX models)) and related labels/values;
3-Confirms commands



AND USING MENUS

The resources are arranged in a menu that can be accessed by pressing and quickly releasing the “set” button (Machine Status menu) or holding down the “set” button for more than 5 seconds (Programming menu). To access the contents of each folder indicated by the relevant label, just press the “set” button once. You can now scroll through the contents of each folder, modify it or use its functions. If you do not use the keyboard for over 15 seconds (time-out) or if you press the “fnc” button once, the last value shown on the display is confirmed and you return to the previous screen mask.

MACHINE STATUS MENU

(See Machine Status Menu Diagram)

To access the Machine Status menu, press the “set” button and quickly release it (The “SP1” label appears. **VI MODELS ONLY**) (If alarms are active, with the exception of faulty probes/probe errors, the “AL” label appears). By using the “UP” and “DOWN” buttons you can scroll through the other folders in the menu: the folders are indicated below in the order they appear:

-AL: alarm folder **LX MODELS ONLY**

NOTE: The AL folder appears if high or low temperature alarms are present.



Alarm (IF PRESENT)
•ON for active alarm;
•blinking for silenced alarm that is still present

decimal point:
associated with displaying decimal point
•ON if enabled-decimal point present (see ndt parameter);
•OFF if disabled-decimal point NOT present (see ndt parameter);

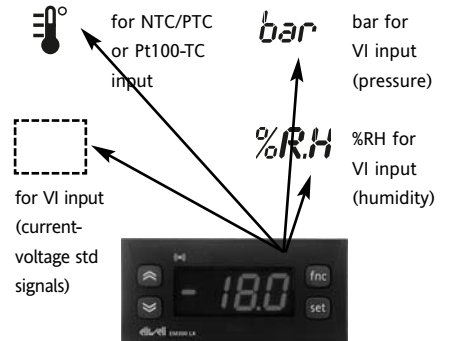

LEDS AND KEYPAD

ALARM PRESENT?

If an alarm condition exists when the “Machine Status” menu is accessed, the “AL” folder label appears with the alarm codes. (see section on “Diagnostics”).

HOW TO LOCK THE KEYBOARD

Keyboard operating can be locked by programming the “Loc” parameter (see folder with “diS” table). If the keyboard is locked you can only access the Programming MENU (see) Functions CANNOT be activated with buttons (to silence alarms, for example).

TELEVIS SYSTEM (LX MODELS ONLY)

The Televis remote control systems can be connected using the TTL serial port. The TTL- RS 485 interface module must be used:

- 130 or 150 BUS ADAPTER.
- 350 BUS ADAPTER for EM300(LX) with VI. Pt100/TC input.

To configure the instrument to do this, you need to access the folder with the “Add” label and use the “dEA” and “FAA” parameters.

PROGRAMMING MENU DIAGRAM

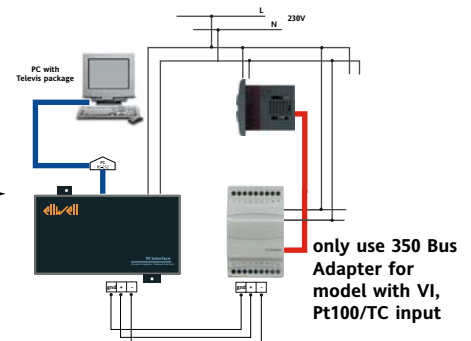
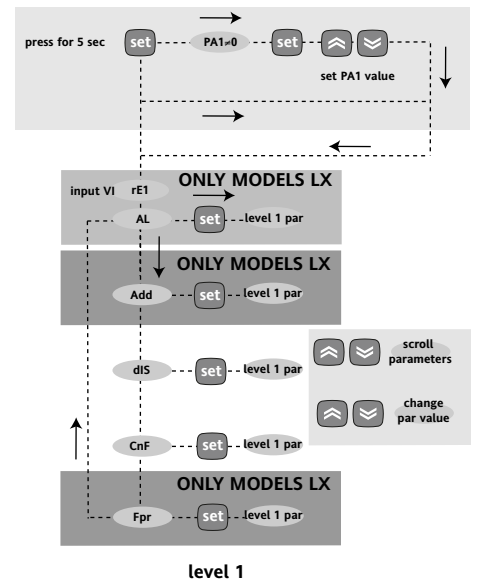

MACHINE STATUS MENU DIAGRAM

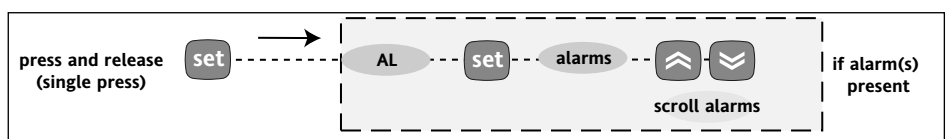

PROGRAMMING MENU

(See Programming Menu Diagram)

1) Displaying level 1 parameters

To access the Programming menu, hold the "set" button for more than 5 seconds.

Level 1 parameters can be protected by a PASSWORD* (defined by parameter DIS/PA1) If the PASSWORD is enabled, the label "PA1" will appear when you access the **Programming Menu**; press the "set" button and the value "0" will appear; enter the password using the "UP"/"DOWN" buttons and press the "set" button again. This

allows you to access the level 1 parameters. Use the "UP" and "DOWN" buttons to scroll through the other folders; **the folders will only display level 1 parameters.**

PLEASE NOTE: It is strongly recommended that the unit is switched off and on again each time parameter configuration is changed in order to prevent malfunctioning of the configuration and/or ongoing timings (**compulsory for selection of probe type and count parameters**).

*PASSWORD

The "PA1" password allows level 1 and level 2 parameters to be accessed. This password is not present in the standard configuration. To enable it (value ≠0) and assign it the desired value, access the Programming menu in the "diS" folder. If the password is enabled, it will be requested when entering the "Programming" menu.

USING COPY CARD (LX MODELS ONLY)

The Copy Card is an accessory connected to the TTL serial port used for quick programming of the unit parameters (upload and download parameter map to one or more units of the same type). Operations are described below:

Fr-Format

This command is used to format the copy card. This is **necessary** if

- it is used for the first time,
- it is used with models that are incompatible,
- after use with a specific model, another model must be connected.

Warning: when the copy card has been programmed using the "Fr" parameter all the data entered is cancelled. This operation cannot be undone.

UL-Upload

This operation unloads the programming parameters from the instrument.

dL-Download

This operation downloads the programming parameters to the instrument.

NOTE:

- **UPLOAD: instrument → Copy Card**
- **DOWNLOAD: Copy Card → instrument.**

The operations are performed by accessing the folder identified by the "FPr" label and selecting the "UL", "dL" or "Fr" commands. The operation is confirmed by pressing the "set" button. If the

operation is successful, a "y" is displayed whereas if it is unsuccessful an "n" will be displayed.

Download "from reset"

Connect the copy card with the instrument OFF.

When the instrument is switched on the programming parameters will be downloaded into the copy card; when the lamp test has been completed, the following appear on the display for about 5 seconds:

- label dLY if copy operation is successful
- label DLn if operation fails

PLEASE NOTE:

- after downloading the instrument will work with the parameter map settings that have just been downloaded.

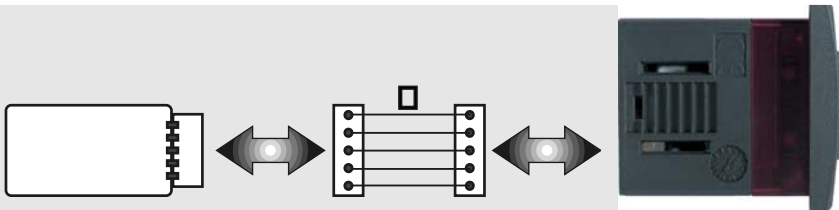

DIAGNOSTICS

The alarm condition is always signalled by a buzzer (if present) and the alarm icon LED (🔊) **(IF PRESENT)**

The alarm signal from the

- control probe that measures values outside the nominal reading range
- control probe faulty/shorted/open probe for 4...20 mA* model appears directly on the instrument display as E1. Note: to prevent false alarms, the error condition must persist for more than 10 seconds.

An error condition in probe 1 (regulation) leads to:

- E1 code appearing on display

PLEASE NOTE: In case of wrong connection of the 3rd wire (Pt100 sensor) in "AL" folder it will appear the label "Pt3".

For few seconds the display will show an incorrect temperature.

MAXIMUM AND MINIMUM TEMPERATURE ALARM

If an alarm condition occurs and alarm exclusion times are not in progress (see alarm exclusion parameters), the fixed alarm icon comes on.

Table of faulty probes

DISPLAY	FAULT
E1	Probe 1 (control) faulty*

*faulty/shorted/open probe for 4...20 mA model; the other probes, if shorted, will measure the 0V or 0mA value)

Alarms are considered as absolute values This alarm condition can be viewed in the "AL" folder with labels "AH1-AL1".

The maximum temperature alarm occurs when the probe temperature is:

- higher than or equal to HAL/HA1

Alarm table

DISPLAY	ALARM
AH1	High temperature alarm (referring to thermostat control probe or probe 1)
AL1	Low temperature alarm (referring to thermostat control probe or probe 1)

Press any button to silence the alarm. The LED will start to blink.

The minimum temperature alarm occurs when the probe temperature is lower than or equal to LAL/LA1

The maximum temperature alarm back swing occurs when the probe temperature is:

- higher than or equal to HAL/HA1 - AFd

Minimum temperature alarm back swing occurs when the probe temperature is:

- higher than or equal to LAL/LA1 + AFd

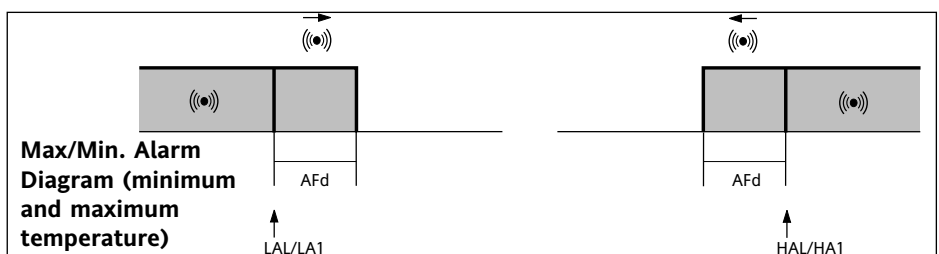

ELECTRICAL WIRING

Warning! Always switch off machine before working on electrical connections.

The instrument has screw terminals for connecting electrical cables with a diameter of 2,5 mm²max. (only one conductor per terminal for power connections). for terminal capacity, see the label on the instrument. Make sure that the power voltage complies with the device voltage. Probe cables, power supply cables and the TTL serial cable should be kept separate from power cables.

The sensor can be extended using an ordinary bipolar cable (note that extending the probe may affect the electromagnetic compatibility (EMC) of the instrument: special care must be used when wiring).

- **version with PTC/NTC input**

The sensor has no connection polarity.

- **version with VI/Pt100-TC input**

NOTE: Check the probe connection polarity.

NOTE: The technical characteristics in this document concerning measurements (range, accuracy, resolution, etc.) refer to the instrument in the strictest sense and not to any accessories provided such as probes, for example. This means that an error introduced by the probe is added to any error that is in the instrument.

GENERAL TECHNICAL DATA

Front protection: IP65. Casing: PC+ABS UL94 V-0 resin plastic body, polycarbonate front, thermoplastic resin buttons.
 Dimensions: front panel 74x32 mm, depth 30 mm (terminals excluded).
 Mounting: on panel, with drilling template 71x29 mm (+0.2/-0.1 mm).
 Operating temperature: -5...55 °C.
 Storage temperature: -30...85 °C.
 Usage ambient humidity: 10...90 % RH (non-condensing).
 Storage ambient humidity: 10...90% RH (non-condensing).

Buzzer output: only in certain models.

(LX MODELS ONLY)

Serial: TTL for connection to

- Copy Card;
- TelevisSystem.

Consumption:

- 230V model: 1,8 W max.;
- 12V model: 0.5 W max.

Power supply: 230V~ ±10% 50/60 Hz or 12V~/~ ±10% 50/60 Hz.

Warning: check the power supply specified on the instrument label: contact the Sales Office for further information

Analogue input table

Model	Analogue input
EM300(LX)	NTC-PTC probe
EM300(LX)	Pt100-TcK-Tcj probe
EM300(LX)	EWPA 007/030
EM300(LX)	EWHS 280/300/310*
EM300(LX)	0...1/5/10 V voltage input
EM300(LX)	0/4...20mA current input

NOTE: For TECHNICAL DATA and connections using EWPA and EWHS probes refer to the relevant technical data sheets and/or diagram on last page.

* external power supply.

For external power supply characteristics, see characteristics of connected sensor.

EM300(LX) TECHNICAL DATA

WITH PTC/NTC INPUT

Display range:

- NTC probe: -50.0...110.0°C (-58...230°F);
 - PTC probe: -55.0...140.0°C (-67...284°F)
- on display 3 1/2 digits + sign.

Analogue input: one PTC or NTC input (parameter-selectable).

Measurement range: from -55 a 140 °C.

Accuracy: better than 0.5% of bottom scale + 1 digit.

Resolution: 0.1°C (0.1°F up to +199.9°F; 1°F above).

WITH VI INPUT

Display range:

-99...100 (ndt = n), -99.9...100.0 (ndt = y), -999...1000 (ndt = int) on display 3 1/2 digits + sign.

Analogue input (see table): a V-I input (0-1V, 0-5V, 0-10V; 0...20mA, 4...20mA) (parameter-selectable);

Measurement range: from -999 to 1000.

Accuracy: better than 0.5% of bottom scale + 1 digit.

Resolution: 1 or 0.1 digits depending on parameter settings.

Current input impedance: 100 ohm

Voltage input impedance: 20K ohm

NOTE: for 3-wire sensor connections the maximum current supplied by the device is 25mA (measurement + sensor power supply)

WITH PT100-TC INPUT

Viewing range:

- Pt100 model : -200...800°C (-328...1472°F),
 - Tcj model -40...760°C (-40...1400°F),
 - TcK model -40...1350°C (-40...2462°F)**
- ** (-40..1999°F) above which SuP is displayed, with decimal point, selectable through parameter ndt on 3 digit & 1/2 + mark display.

Analogue input: one PT100 input or Tcj or TcK depending on model.

Measuring range: from -200 to 1999.

Accuracy:

- Pt100 model : 0,5% for all scale + 1 digit; 0,2% from -150 to 300°C.
- Tcj model: 0,4% for all scale + 1 digit;
- TcK model 0,5% for all scale + 1 digit; 0,3% from -40 to 800°C.

Resolution:

- Pt100 model: 0,1°C (0,1°F) within 199,9 °C, 1°C (1°F) over
- Tcj/TcK model 1°C (1°F).

Power supply: 12/24 V~/~ ±10% or 230V~ ±10% 50/60 Hz.

NOTE: in model Pt100 the thermal drift in the -5...55°C range can reach 3°C.

MECHANICAL ASSEMBLY AND CUT-OUT

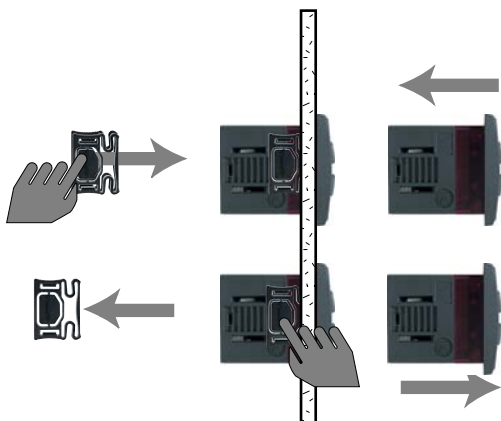

The unit has been designed to be panel-mounted: Drill a 29x71 mm hole, insert the keyboard and fix it in place with the special brackets provided. Do not assemble the keyboard in excessively dirty and/or dirty locations because it is designed to be used in locations with normal pollution levels. Always make sure that the area next to the unit cooling slits is adequately ventilated.

PARAMETER TABLE FOR EM300(LX) with NTC/PTC probe

PARAMETER	DESCRIPTION	RANGE	DEFAULT*	VALUE**	U.M.
ALARMS (folder with "AL" label) LX MODELS ONLY					
AFd	Alarm Fan differential. Alarm differential.	1.0...50.0	2.0		°C/°F
HAL (!)	Higher ALarm. Maximum temperature alarm. Temperature value (considered as absolute value) which if gone above triggers the alarm signal.	LAL...150.0	50.0		°C/°F
LAL (!)	Lower ALarm. Minimum temperature alarm. Temperature value (considered as absolute value) which if gone below triggers the alarm signal.	-50.0...HAL	-50.0		°C/°F
PAO (!)	Power-on Alarm Override. Alarm exclusion time after instrument start-up, after a power failure.	0...10	0		hours
tAO	Temperature Alarm Override. Temperature alarm signal delay time.	0...250	0		min
tP	silences alarm with button	n/y	y		flag
COMMUNICATION (folder with "Add" label) LX MODELS ONLY					
dEA (!)	DEA= device number within the family (valid values: from 0 to 14)	0...14	0		num
FAA (!)	FAA= device family (valid values: from 0 to 14) The value couple FAA and dEA represents the network address of the device and it is indicated in the following way: "FF.DD" (where FF=FAA and DD=dEA).	0...14	0		num
DISPLAY (folder with "diS" label)					
LOC	Keyboard locked (set point and buttons). However, you can still access the parameter programming menu and modify parameters including the status of this parameter to allow keyboard unlocking, y = yes; n = no.	n/y	n		flag
PA1	Password 1. When enabled (value is not 0) it represents the access key to level 1 parameters.	0...250	0		num
ndt	number display type. Display with decimal point. y = yes; n = no, int= whole numbers.	n/y	n		flag
CA1	Calibration 1. Positive or negative temperature value that is added to the value read by control probe (analogue input) before being displayed or used for regulation.	-12.0...12.0 (-30.0...30.0) (§)	0		C/°F
LdL	Minimum value that can be displayed.	-55.0...HdL (-328.0...HdL) (§)	-50.0 (-200 (§))		C/°F
HdL	Maximum value that can be displayed. Select °C or °F to display	LdL...302 (LdL...1999) (§)	140.0 (1500 (§))		flag
dro(*)	temperature read by probe. N. B.: when changing from °C to °F or vice versa the temperature values are NOT converted (e.g. 10°C becomes 10°F)	0/1	0		
CONFIGURATION (folder with "CnF" label)					
H00 (!)	Selection of input type, PTC/NTC	0/1	*		flag
rEL	Device version. Read only parameter.	/	/		/
tAb	Reserved. Read only parameter.	/	/		/
COPY CARD (folder with "Fpr" label) LX MODELS ONLY					
UL	UpLoad: transfer of programming parameters from instrument to Copy Card.	/	/		/
dL	downLoad: transfer of programming parameters from Copy Card to instrument.	/	/		/
Fr	Format. Cancels all data entered in the copy card. N.B.: if "Fr" parameter (formatting of copy card) is used the data entered in the card will be permanently lost. This operation cannot be undone. After the operation with the Copy Card the device must be switched off and then switched back on	/	/		/

(§) Pt100/TC model

* DEFAULT column: for these parameters the default depends on the model.

** VALUE column: to be compiled manually with any custom settings (if different from default value).

(*) The mathematical conversion for temperature is $^{\circ}\text{F}=(9/5)^{\circ}\text{C}+32$. For example: $32^{\circ}\text{F}=0^{\circ}\text{C}$;

$50^{\circ}\text{F}=10^{\circ}\text{C}$. dro parameter: when changing from °C to °F or vice versa the mathematical conversion is NOT performed and the values are NOT modified.

All the temperature values set will therefore need reviewing, e.g. with a set point set at 10°C, when changing the value to °F the set point will become 10°F and not 50°F (according to conversion table)

RESPONSIBILITY AND RESIDUAL RISKS

Eliwell & Controlli s.r.l. shall not be liable for any damages deriving from:

- installation/use other than that prescribed and, in particular, which does not comply with the safety standards specified in the regulations and/or those given herein;
- use on equipment that does not guarantee adequate protection against electric shock, water or dust when assembled.
- use on equipment that allows dangerous parts to be accessed without the use of tools;
- tampering with and/or alteration of the product;
- use on equipment that does not comply with the standards and regulations in force.

DISCLAIMER

This document is exclusive property of Eliwell & Controlli s.r.l. and cannot be reproduced and circulated unless expressly authorized by Eliwell & Controlli s.r.l..

Although Eliwell & Controlli s.r.l. has taken all possible measures to guarantee the accuracy of this document, it declines any responsibility for any damage arising out of its use.

The same applies to any person or company involved in preparing and writing this manual. Eliwell & Controlli s.r.l. reserves the right to make any changes or improvements without prior notice and at any time.

CONDITIONS OF USE

PERMITTED USE

For safety reasons the instrument must be installed and used in accordance with the instructions supplied. Users must not be able to access parts with dangerous voltage levels under normal operating conditions.

The device must be protected from water and dust depending on the specific application and only be accessible by using special tools. (except for the front panel).

The device is ideally suited for use on household appliances and/or similar refrigeration equipment and has been tested with regard to safety in accordance with the European harmonized reference standards.

It is classified as follows:

- Installation: Class II where applicable (front keypad)
- Protection class: 2
- Material group: IIIa
- Device status: Permanently connected fixed device.
- Measurement category: III

UNPERMITTED USE

The use of the unit for applications other than those described above is forbidden.

PARAMETER TABLE FOR EM300(LX) with V/I & Pt100-TC input

LX MODELS ONLY

PARAMETER	DESCRIPTION	RANGE (VI)	RANGE (Pt100)	DEFAULT*	VALUE**	U.M.
HA1 (!)	ALARMS (folder with "rE1" label) LX MODELS ONLY Higher ALarm. Maximum temperature alarm. Temperature value (considered as absolute value) which if gone above triggers the alarm signal.	LA1...150.0	LA1...1999	*	(§) 1200	°C/°F
LA1 (!)	Lower ALarm. Minimum temperature alarm. Temperature value (considered as absolute value) which if gone below triggers the alarm signal.	-50.0...HA1	-328...HA1	*	(§) -200	°C/°F
AFd	ALARMS (folder with "AL" label) LX MODELS ONLY Alarm Fan differential. Alarm differential.	1.0...50.0	1.0...50.0	2.0		°C/°F
PAO (!)	Power-on Alarm Override. Alarm exclusion time after instrument start-up, after a power failure.	0...10	0...10	0		hours
tAO	Temperature Alarm Override. Temperature alarm signal delay time.	0...250	0...250	0		min
tP	silences alarm using button	n/y	n/y	y		flag
LX MODELS ONLY	COMMUNICATION (folder with "Add" label) LX MODELS ONLY SEE EM300 TABLE above DISPLAY (folder with "diS" label) SEE EM300 TABLE above VI MODELS ONLY: NOTE 1: ndt parameter has range n/y/int int=whole numbers. NOTE 2: Ldl has range -99...Hdl or -99.9...Hdl or -999...Hdl according to ndt parameter setting Hdl has range -Ldl...100 or -Ldl...100.0 or -Ldl...1000 according to ndt parameter setting CONFIGURATION (folder with "CnF" label)					
H00 (!)	Selection of probe type	§§§	(§) Jtc/HtC/Pt1	(§) 2		num
H03	Minimum value of current input	-99.0...100.0 (ndt= y) -999...1000 (ndt= int)	not present	*		C/°F
H04	Maximum value of current input	as above	not present	*		C/°F
rEL	Device version. Read only parameter.	/	/	/		/
tAb	Reserved. Read only parameter.	/	/	/		/
LX MODELS ONLY	COPY CARD (folder with "Fpr" label) LX MODELS ONLY SEE EM300 TABLE above				§§§	
	* DEFAULT column: for these parameters the default depends on the model.		(§) Pt100/TC model		010/05/01 for VOLTAGE INPUT 420/020 for CURRENT INPUT	

(!) CAUTION!

- If one or more parameters marked with (!) are modified, the device must be switched off after the modification and then switched back on
- **PLEASE NOTE:** We strongly recommend that you switch the instrument off and on again each time parameter configuration is changed in order to prevent malfunctioning of the configuration and/or ongoing timings.

WIRING DIAGRAMS

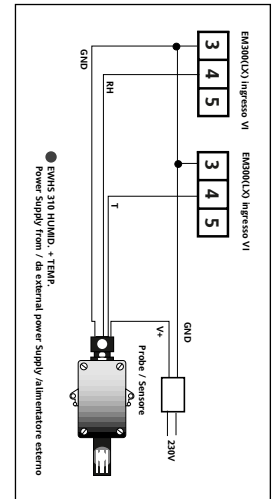
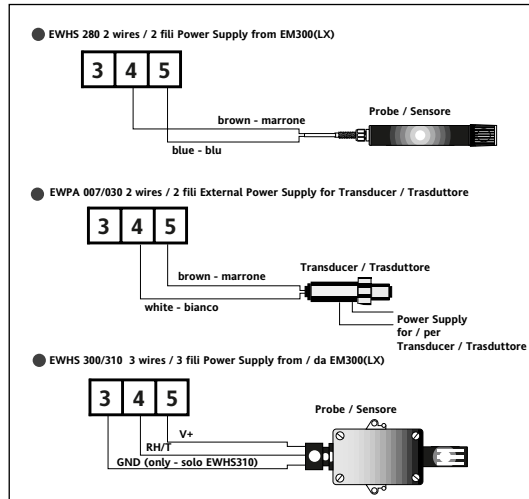
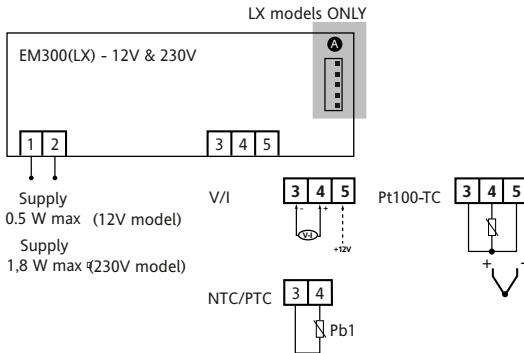

Eliwell & Controlli s.r.l.
Via dell'Industria, 15 Zona Industriale Paludi
32010 Pieve d'Alpago (BL) ITALY
Telephone +39 0437 986111
Facsimile +39 0437 989066
Internet <http://www.eliwell.it>

Technical Customer Support:
Email: techsuppeliwell@invensys.com
Telephone +39 0437 986300

Invensys Controls Europe
Part of the Invensys Group
3/2005 eng
code 9IS43049



TERMINALS

NTC/PTC Models

- 1 - 2 Power supply 230V~ ±10%
50/60 Hz or 12V± ±10% 50/60 Hz.
- 3 - 4 Pb1 probe input

VI Models

- 3 - 4 - 5 Voltage input
(3=GND; 4=signal; 5=+12V)*
- 3 - 4 - 5 Current input
(3=GND; 4=signal; 5=+12V)*

Pt100-TC Models

- 4 - 5 Tcj-Tck Input
- 3 - 4 - 5 Pt100 3 wires Input

LX MODELS ONLY

- A TTL input for Copy Card and connection to **TelevisSystem**

* according to model
* Check probe connection polarity.