

INFRARED CERAMIC HEATERS

318-332 TO 338



APPLICATIONS

Mass Heating:

- Softening plastics for thermoforming machines
- Heat setting fabrics
- Solder reflow / wave ovens
- Glass to metal sealing and glass bending

Drying Applications:

- Paper webs and impregnated coatings
- Water-based inks, coatings and adhesives
- Wood and chipboard
- Glaze in ceramics

Stoving and Curing applications

- Sprayed and dipped powder coatings
- P.T.F.E. coatings
- Car finishes and underseals
- Print lamination

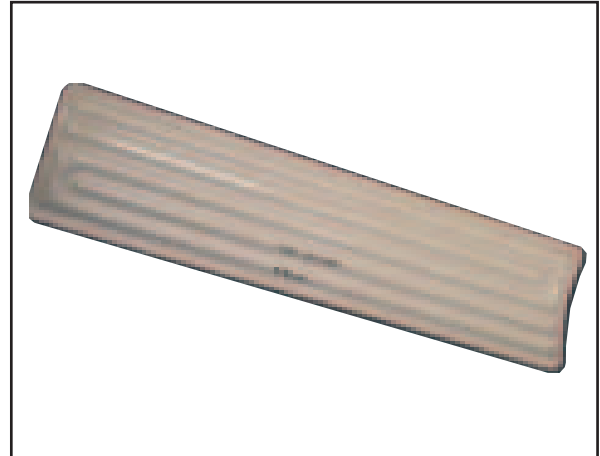

DESCRIPTION

The Ceramic Heater is an efficient, robust heater which provides long wave infrared radiation. They are used in applications ranging from thermo-forming to paint curing. Nearly all materials to be heated or dried provide maximum absorption in the 3 - 10 microns range. The Ceramic Heater was developed with this fact in mind, and is the reason why they can be applied to such a diverse range of industrial processes.

The Ceramic Heater is produced using a specialised process which involves an alloy resistance wire around which is cast a ceramic body. This body is then glazed to protect it from moisture ingress. It also protects the heater from atmospheric and corrosive attack. In this way the ceramic element optimises the maximum absorption characteristics, as they operate at temperatures of 300°C to 750°C (300°F to 750°F) producing a wavelength of 3-6 microns. The ceramic heater has been designed offer high efficiency (up to 85% in properly designed systems), flexibility in zoning, interchangeability for maintenance, long life and uniformity from element to element

INSTALLATION

The diagram below shows the installation arrangement for a ceramic heater. The element is pushed up into the aluminised steel reflector, then the wave spring is placed over the power leads and over the element retainer and then secured with the clip which is slid into position as shown to retain the element in place. This system of retention allows the element to expand and contract within the reflector as it heats up and cools down. The wave spring and clip are provided with each ceramic element but the reflector is sold as a separate item

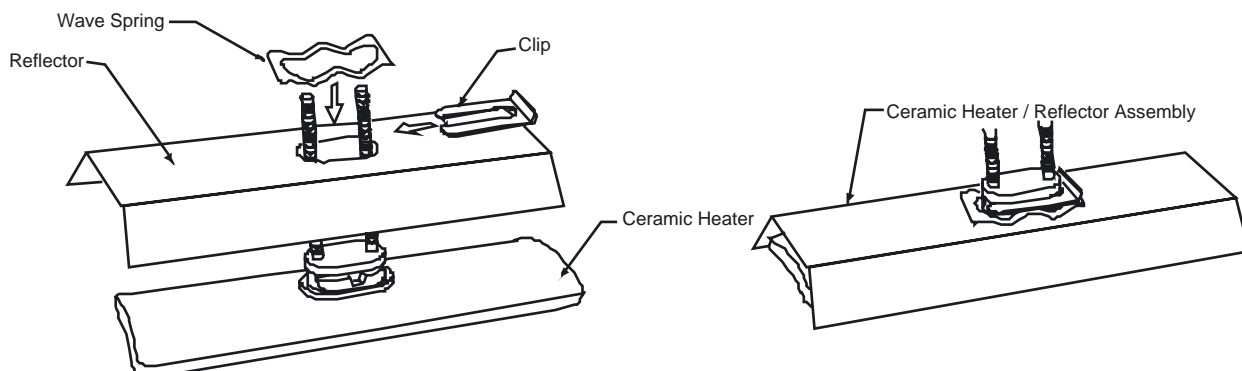

SPECIFICATIONS

Element:	Nichrome resistance wire
Target Distance:	100....200mm from heater surface
Dimensions:	245 x 60 x 35mm F.T.E. & 122 x 60 x 35mm for H.T.E. version
Heater Voltage:	230 Vac
Heater Wavelength Range:	3 - 6 microns
Heater Connections:	Supplied with 85 ± 10mm ceramic Beaded Flying Leads

Watts W	Type	Mean Surface Temp °C	Wave Length Microns	KW Load Per m ²	Watts m ²
150	F.T.E.	315	6.0	6	6.5
250	F.T.E.	418	4.9	10	11
300	F.T.E.	452	4.6	12	13
350	F.T.E.	480	4.5	14	15
400	F.T.E.	515	4.2	16	17
500	F.T.E.	560	4.0	20	22
600	F.T.E.	590	3.6	24	25
650	F.T.E.	630	3.55	26	28
750	F.T.E.	670	3.5	30	33
800	F.T.E.	685	3.4	32	38
1000	F.T.E.	700	3.0	40	44
125	H.T.E.	418	4.9	10	11
150	H.T.E.	452	4.6	12	13
200	H.T.E.	515	4.2	16	17
250	H.T.E.	560	4.0	20	22
325	H.T.E.	630	3.55	26	28
400	H.T.E.	685	3.4	32	38
500	H.T.E.	750	3.1	40	44

Long Wave radiation curing, heating and drying is an environmentally friendly, portable and cost effective method of heating. They have a cast-in nichrome resistance wire operating at the temperatures of 300°C to 750°C (572°F to 1382°F). The glazed ceramic surface protects it from oxidation or corrosion. optimum absorption of radiant energy operates at temperatures between 300°C to 750°C (572°F to 1382°F) producing a wavelength range of 3 - 6 microns. The ceramic element is produced to optimise these essential and valuable characteristics which in turn improves the efficiency and quality in the radiated product. This matches the ideal absorption wavelengths of materials such as plastics, paper and water ensuring rapid heat-up times making it ideal for industrial heating and drying applications. A range of aluminised steel reflectors are also available to ensure that most of the heat generated is reflected forward on to the target area

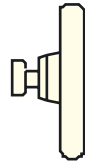
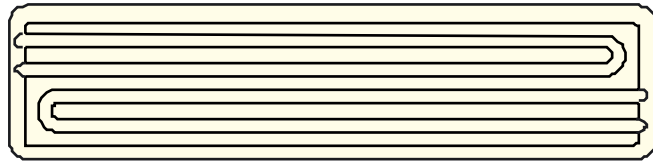

(F.F.E)
Full Flat Element
245 x 60 mm

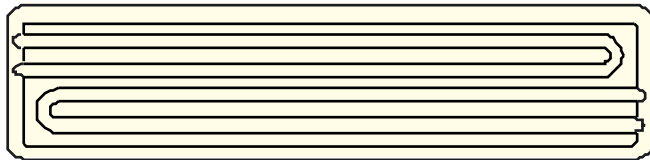

(F.T.E)
Full Trough Element
245 x 60 mm

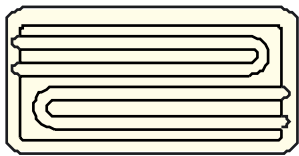

(H.F.E)
Half Flat Element
122 x 60 mm

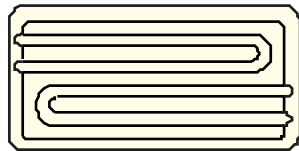

(H.T.E)
Half Trough Element
122 x 60 mm

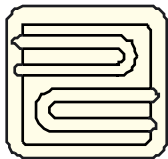

(Q.F.E)
Quarter Flat Element
60 x 60 mm



(Q.T.E)
Quarter Trough Element
60 x 60 mm

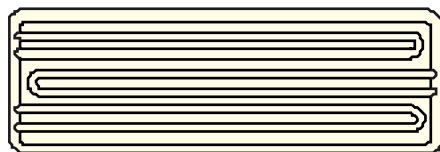

(L.F.F.E)
Large Full Flat Element
245 x 97 mm



(L.F.T.E)
Large Full Trough Element
245 x 60 mm

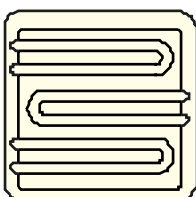

(S.F.S.E)
Square Flat Solid Element
122 x 122 mm