

GENERAL DATA

Application	HMBP
Refrigerant	R22
Evaporating °C	-25 - 10
Comp. cooling	Fan cooled
Max. ambient temp. °C	38

CONDENSER DATA

Condenser type	CU-AL
Condenser model	9T 4R
Evaporating (W)	10
Fan blade diameter (mm)	230

COMPRESSOR DATA

Displacement (cm ³)	8.0
Bore/Stroke (mm)	25,40/17,47
Motor type	CSIR
Voltage/Frequency	220V 50Hz
Voltage range (V)	187-264
Locked rotor current (A)	15.0
Main W. resist. at 25°C (Ω)	4.0
Start W. resist. at 25°C (Ω)	20.0

VERSIONS

3 -Service valve and receiver (CL88TN3M)
 Receiver, approx. vol. 1.0 l
 Suction tube internal diam. 3/8F in
 Discharge tube internal diam. 3/8R in

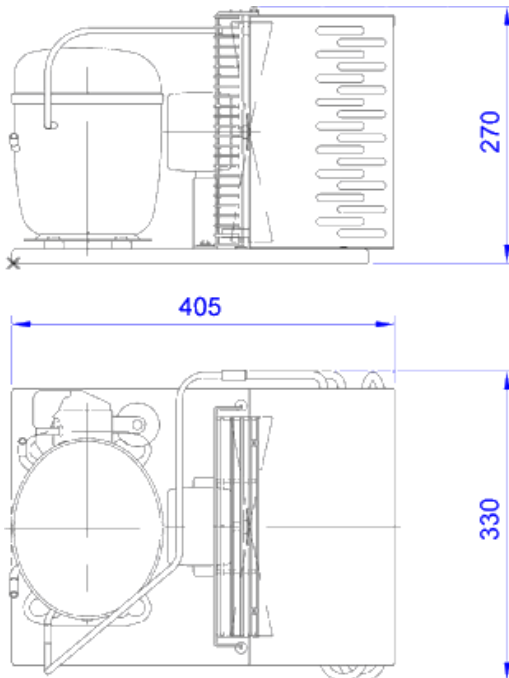
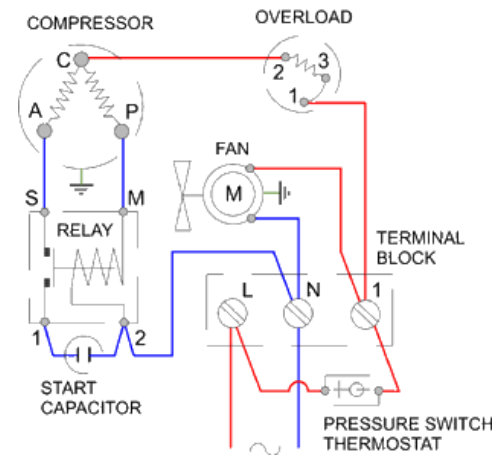
DIMENSIONS AND ELECTRICAL DIAGRAM

CSIR

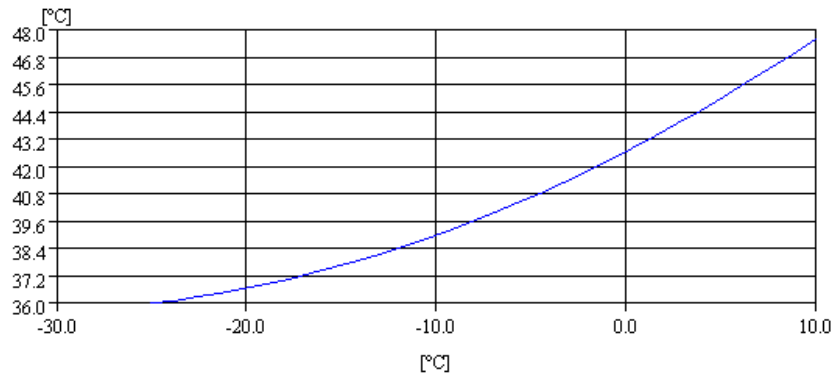
CONDENSING TEMPERATURE

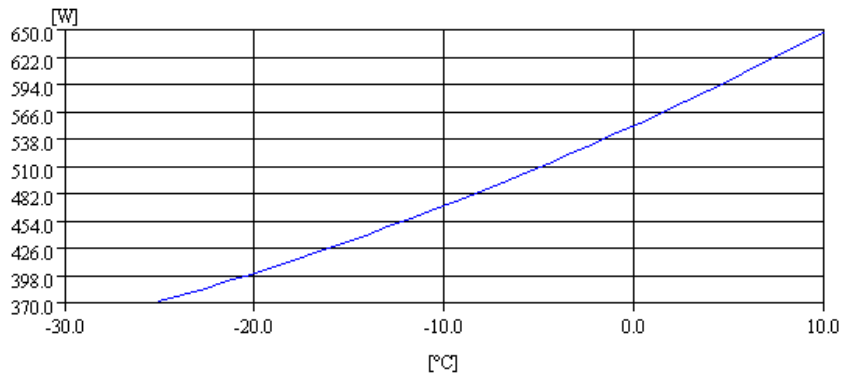

CONSUMPTION



INTENSITY

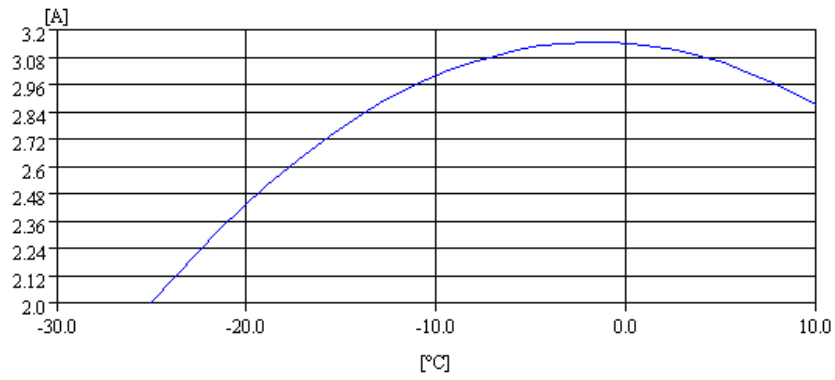

COOLING CAPACITY

