

GENERAL DATA

Application	HMBP
Refrigerant	R134a
Evaporating °C	-25 - 10
Comp. cooling	Fan cooled
Max. ambient temp. °C	43

CONDENSER DATA

Condenser type	CU-AL
Condenser model	11T 4R
Evaporating (W)	25
Fan blade diameter (mm)	254

COMPRESSOR DATA

Displacement (cm ³)	23.0
Bore/Stroke (mm)	34,94/24,21
Motor type	CSIR
Voltage/Frequency	220V 50Hz
Voltage range (V)	187-264
Locked rotor current (A)	26.0
Main W. resist. at 25°C (Ω)	2.0
Start W. resist. at 25°C (Ω)	25.0

VERSIONS

3 -Service valve and receiver (CGX23TB3N)
 Receiver, approx. vol. 1.0 l
 Suction tube internal diam. 3/8F in
 Discharge tube internal diam. 3/8R in

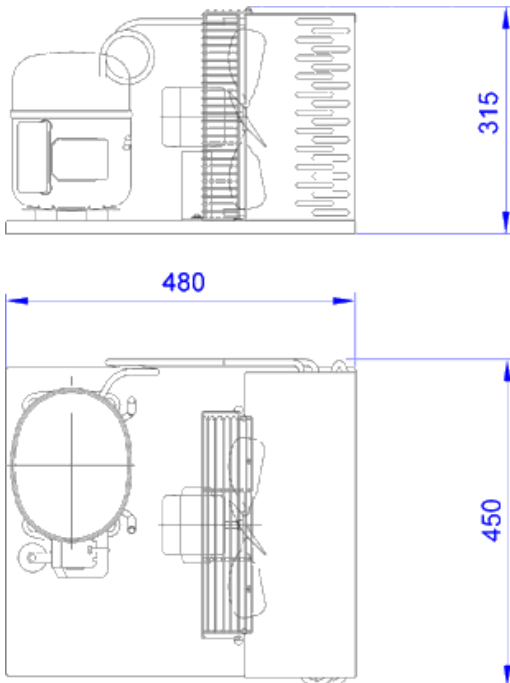
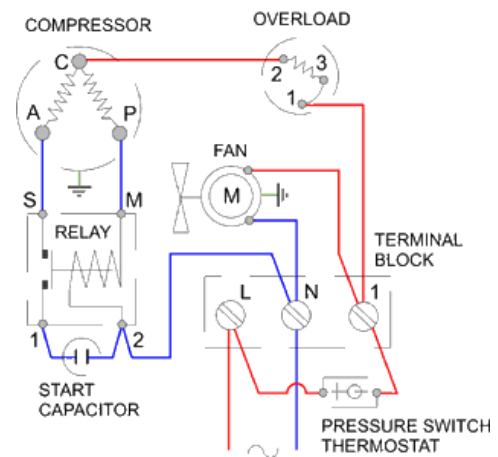
DIMENSIONS AND ELECTRICAL DIAGRAM

CSIR

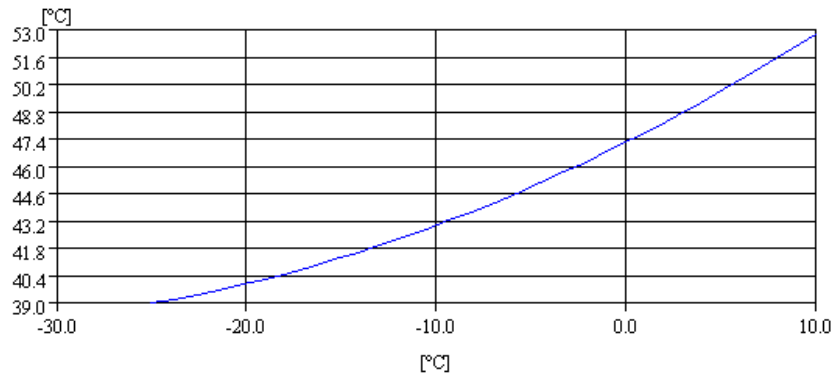
CONDENSING TEMPERATURE

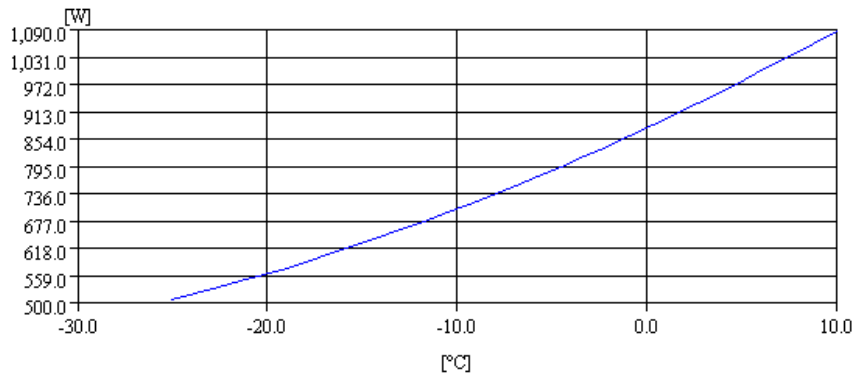

CONSUMPTION



INTENSITY

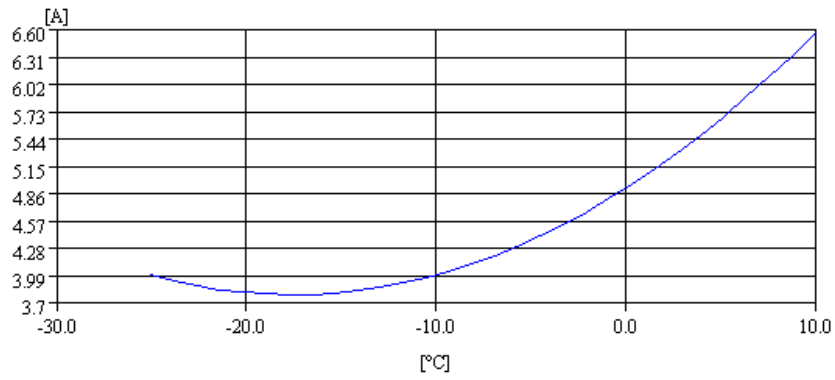

COOLING CAPACITY

