

GENERAL DATA

Application	HMBP
Refrigerant	R134a
Evaporating °C	-25 - 10
Comp. cooling	Fan cooled
Max. ambient temp. °C	43

CONDENSER DATA

Condenser type	CU-AL
Condenser model	12T 3R
Evaporating (W)	25
Fan blade diameter (mm)	300

COMPRESSOR DATA

Displacement (cm ³)	25.0
Bore/Stroke (mm)	39,98/20,65
Motor type	CSIR
Voltage/Frequency	220V 50Hz
Voltage range (V)	187-264
Locked rotor current (A)	32.0
Main W. resist. at 25°C (Ω)	1.0
Start W. resist. at 25°C (Ω)	19.0

VERSIONS

3 -Service valve and receiver (CGS26TB3N)
 Receiver, approx. vol. 2.0 l
 Suction tube internal diam. 5/8R in
 Discharge tube internal diam. 3/8R in

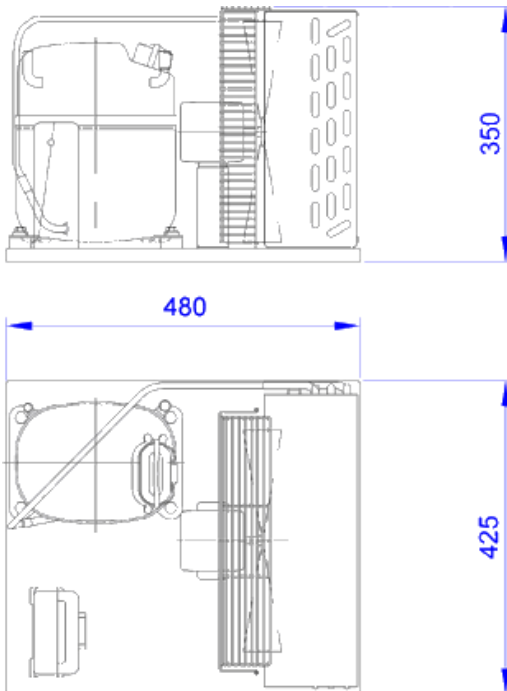
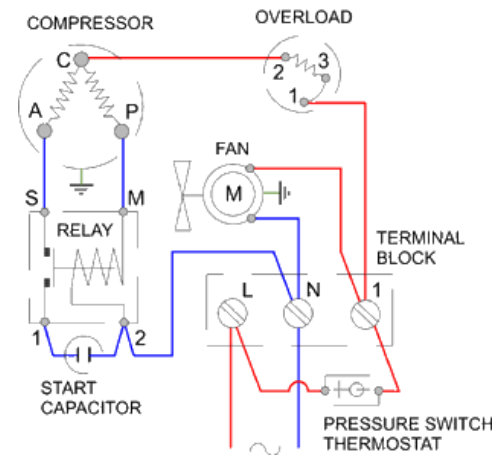
DIMENSIONS AND ELECTRICAL DIAGRAM

CSIR

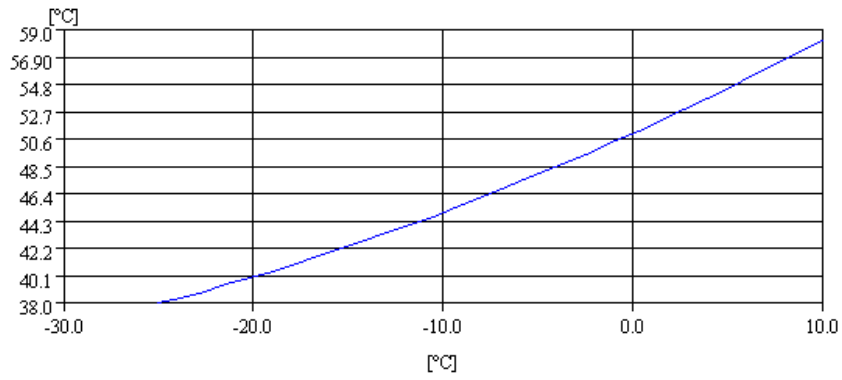
CONDENSING TEMPERATURE

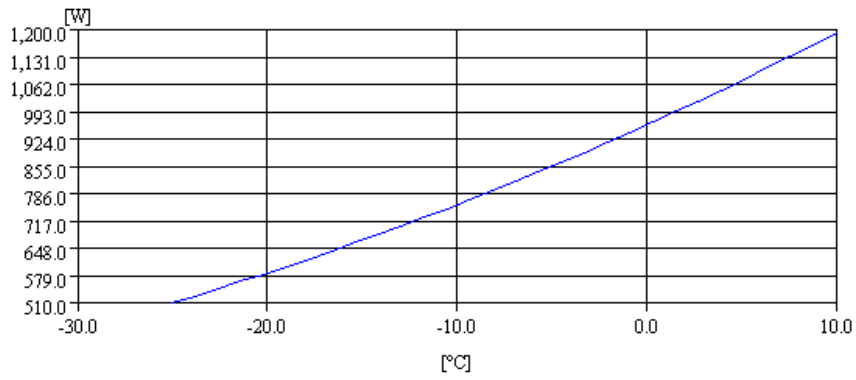

CONSUMPTION



INTENSITY

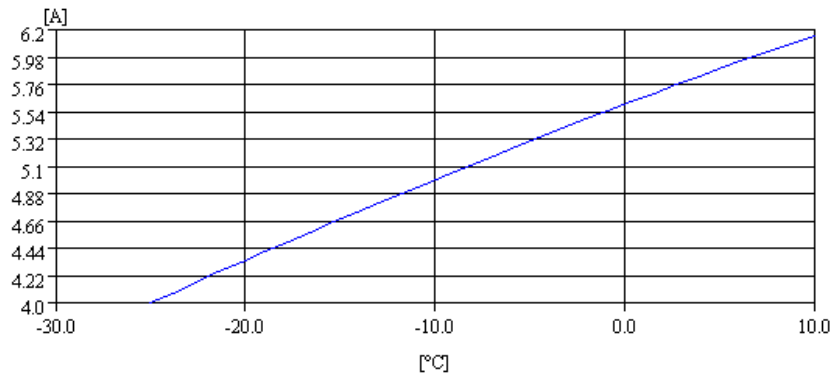

COOLING CAPACITY

