



APPROVALS



ENGINEERING CODE
267BA51

APPROVED REFRIGERANT
R-134a

POWER SUPPLY
220-240 V 50 Hz

STANDARD CONDITIONS
EN12900

APPLICATION
HBP

COOLING CAPACITY
629 W (HBP)

EFFICIENCY
2.26 W/W (HBP)

MOTOR TYPE
CSIR

STARTING TORQUE
HST

DATA

General Data

Type	Hermetic reciprocating
Technology Type	On-Off
Displacement	7.28 cm ³
Compressor Cooling	Fan/NotControlled/220
Fan Air Flow	520 m ³ /h
Expansion Device	Capillary Tube or Expansion Valve
Horse Power	1/4 hp
Max Condensing Pressure Operating	13.92 bar
Max Condensing Pressure Peak	15.62 bar
Power Supply	220-240 V 50 Hz
Evaporating Temperature Range	-15 °C to 10 °C

Electrical Data

Motor type	CSIR
Starting Torque	HST
Start Winding Resistance	28.9 Ω at 25° C
Run Winding Resistance	6.8 Ω at 25° C

Mechanical Data

Maximum Recommended Refrigerant Charge	350 g
Oil Charge	350 ml
Oil Type Configuration	ESTER
Oil Type Viscosity	ISO22
Pressurization	Dry air charge
Weight	10.4 Kg
Free Internal Volume	2.1 L

Electrical Components

	Description
Start Capacitor	43-53 Uf / 330 V
Motor Protection	T0186/G6
Starting Device	Relay MTRP-42*

External Characteristics

Base Plate	European	
Tray Holder	No	
Height	188 mm	
Connector	Internal Diameter	Shape
Suction	8.1 mm	Slanted 42°/Copper
Discharge	6.1 mm	Straight/Copper
Process	6.1 mm	Slanted 42°/Copper

PERFORMANCE

Rated Points

Condensing Temperature	Evaporating Temperature	Cooling Capacity	Power Consumption	Gas Flow Rate	Efficiency
50.00°C	5.00°C	629 W	278 W	15.81 kg/h	2.26 W/W

Test Condition: EN12900HBP, Fan/NotControlled/220, Return Gas 20°C, Evaporation 5.00°C, Condensing 50.00°C, Ambient 35°C, Liquid 50°C, Subcooling 0K. Data are an indication of performance based simulation.

Performance Curve Data

Condensing Temperature 35°C

Evaporating Temperature °C	Cooling Capacity W	Power W	Gas Flow Rate kg/h	Efficiency W/W
-15	328	178	6.94	1.85
-10	415	193	8.84	2.15
-5	520	207	11.11	2.51
0	642	219	13.82	2.94
5	786	229	17.04	3.43
10	953	237	20.84	4.02

Test Condition: EN12900HBP, Fan/NotControlled/220, Return Gas 20°C, Ambient 35°C, Subcooling OK. Data are an indication of performance based simulation.

Condensing Temperature 45°C

Evaporating Temperature °C	Cooling Capacity W	Power W	Gas Flow Rate kg/h	Efficiency W/W
-15	277	186	6.43	1.49
-10	354	207	8.26	1.71
-5	446	227	10.47	1.97
0	556	244	13.12	2.27
5	684	261	16.29	2.62
10	834	276	20.05	3.02

Test Condition: EN12900HBP, Fan/NotControlled/220, Return Gas 20°C, Ambient 35°C, Subcooling OK. Data are an indication of performance based simulation.

Condensing Temperature 55°C

Evaporating Temperature °C	Cooling Capacity W	Power W	Gas Flow Rate kg/h	Efficiency W/W
-10	295	219	7.65	1.35
-5	374	242	9.76	1.55
0	469	264	12.34	1.78
5	581	285	15.44	2.04
10	713	305	19.13	2.34

Test Condition: EN12900HBP, Fan/NotControlled/220, Return Gas 20°C, Ambient 35°C, Subcooling OK. Data are an indication of performance based simulation.

Operating Envelope

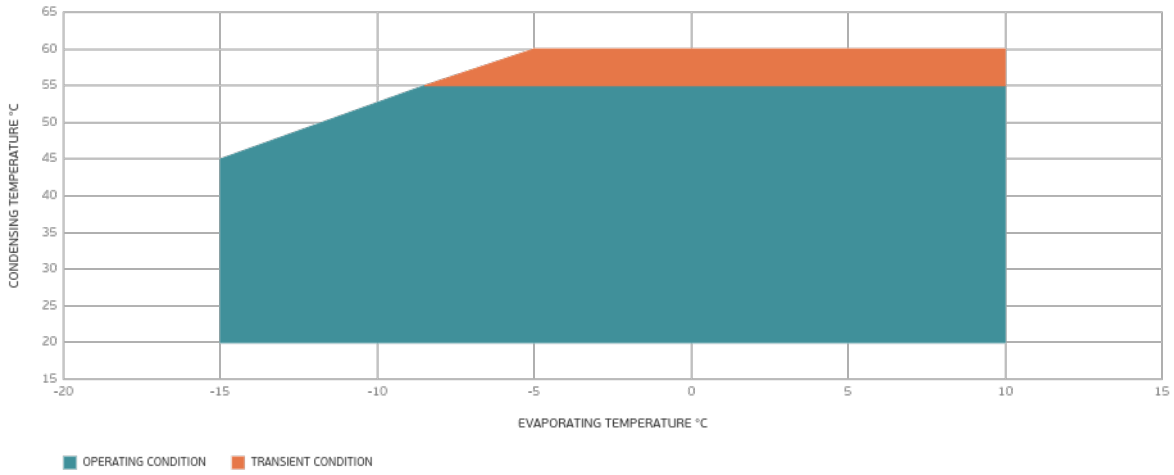

External Dimensions

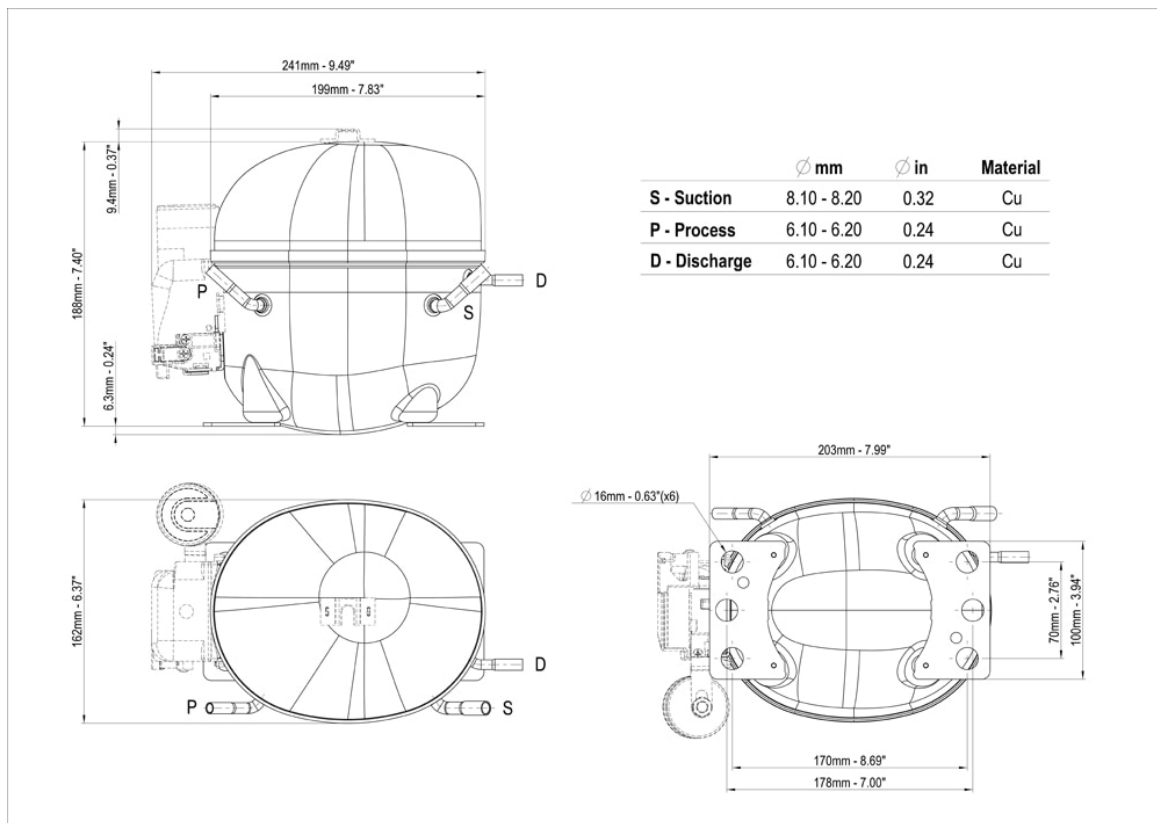

Wiring Diagram

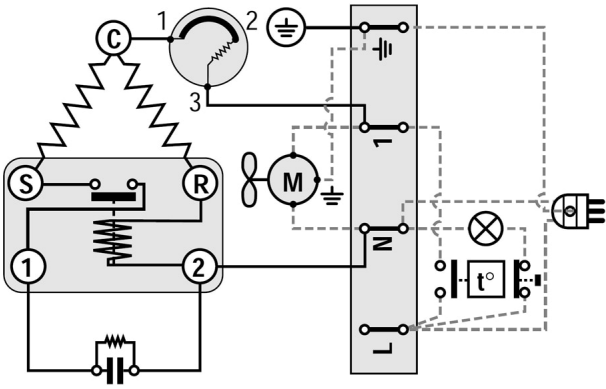

Assembly Instructions

