



**APPROVALS**



**ENGINEERING CODE**  
513306249

**APPROVED REFRIGERANT**  
R-290

**POWER SUPPLY**  
220-240 V 50 Hz

**STANDARD CONDITIONS**  
EN12900

**APPLICATION**  
MBP

**COOLING CAPACITY**  
473 W (MBP)

**EFFICIENCY**  
1.92 W/W (MBP)

**MOTOR TYPE**  
CSIR

**STARTING TORQUE**  
HST

**DATA**

**General Data**

Type	Hermetic reciprocating
Technology Type	On-Off
Displacement	5.96 cm <sup>3</sup>
Compressor Cooling	Fan/NotControlled/220
Expansion Device	Capillary Tube or Expansion Valve
Horse Power	1/3 hp
Power Supply	220-240 V 50 Hz
Evaporating Temperature Range	-20 °C to 10 °C

**Electrical Data**

Motor type	CSIR
Starting Torque	HST
Start Winding Resistance	19.2 Ω at 25° C
Run Winding Resistance	10.1 Ω at 25° C

## Mechanical Data

Oil Charge	180 ml
Oil Type Configuration	ESTER
Oil Type Viscosity	ISO22
Weight	7.8 Kg

## Electrical Components

	Description
Starting Device	Relay   MTRPH-0025-65*
Motor Protection	T0571/G6
Start Capacitor	64-77 Uf / 320 V

## External Characteristics

Tray Holder	Yes	
Connector	Internal Diameter	Shape
Suction	6.1 mm	Slanted 42°/Copper
Discharge	4.94 mm	Straight/Copper
Process	6 mm	Slanted 42°/Copper(OD)

## PERFORMANCE

## Rated Points

Condensing Temperature	Evaporating Temperature	Cooling Capacity	Power Consumption	Gas Flow Rate	Efficiency
45.00°C	-10.00°C	473 W	246 W	5.82 kg/h	1.92 W/W

Test Condition: EN12900MBP, Fan/NotControlled/220, Return Gas 20°C, Evaporation -10.00°C, Condensing 45.00°C, Ambient 35°C, Liquid 45°C, Subcooling 0K. Data are an indication of performance based simulation.

## Performance Curve Data

### Condensing Temperature 35°C

Evaporating Temperature °C	Cooling Capacity W	Power W	Gas Flow Rate kg/h	Efficiency W/W
-20	370	202	4.10	1.83
-15	445	214	4.96	2.09
-10	534	224	5.98	2.39
-5	639	233	7.20	2.74
0	763	242	8.65	3.15
5	907	251	10.39	3.62
10	1076	260	12.44	4.14

Test Condition: EN12900MBP, Fan/NotControlled/220, Return Gas 20°C, Ambient 35°C, Subcooling OK. Data are an indication of performance based simulation.

### Condensing Temperature 45°C

Evaporating Temperature °C	Cooling Capacity W	Power W	Gas Flow Rate kg/h	Efficiency W/W
-20	325	215	3.96	1.52
-15	393	231	4.81	1.7
-10	473	246	5.82	1.92
-5	566	261	7.01	2.17
0	676	276	8.44	2.45
5	804	291	10.14	2.77
10	954	306	12.16	3.12

Test Condition: EN12900MBP, Fan/NotControlled/220, Return Gas 20°C, Ambient 35°C, Subcooling OK. Data are an indication of performance based simulation.

### Condensing Temperature 55°C

Evaporating Temperature °C	Cooling Capacity W	Power W	Gas Flow Rate kg/h	Efficiency W/W
-20	275	234	3.74	1.18
-15	336	252	4.59	1.34
-10	406	269	5.58	1.51
-5	488	287	6.76	1.7
0	584	304	8.16	1.92
5	696	322	9.83	2.16
10	827	341	11.82	2.43

Test Condition: EN12900MBP, Fan/NotControlled/220, Return Gas 20°C, Ambient 35°C, Subcooling OK. Data are an indication of performance based simulation.

## Operating Envelope

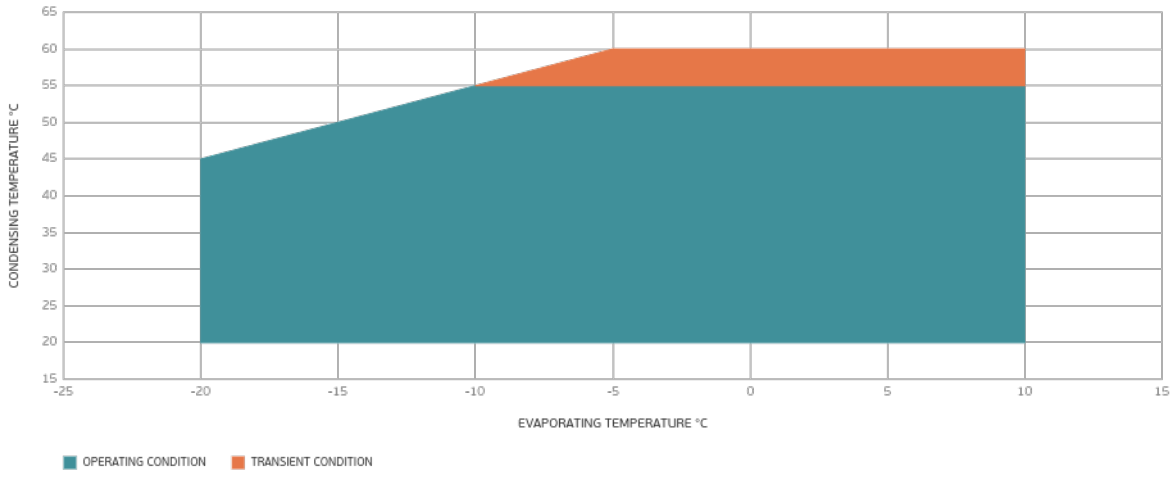

## External Dimensions

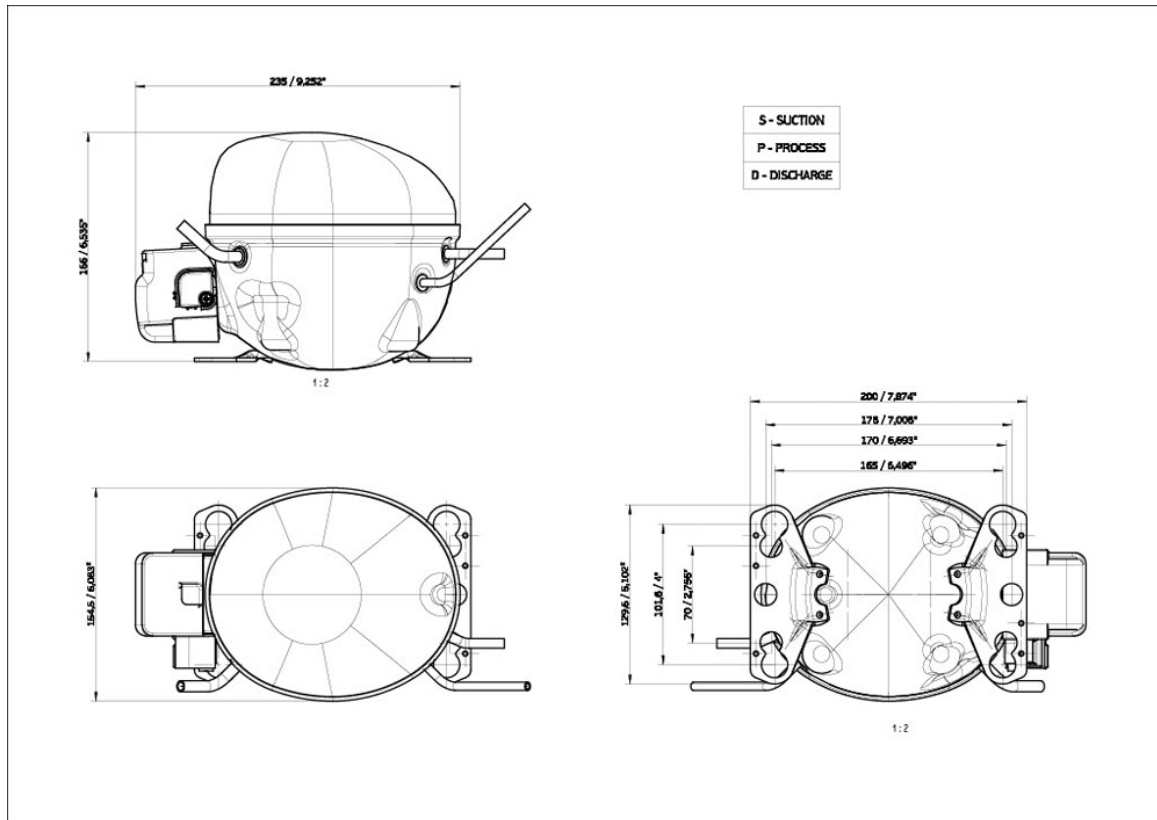

# Wiring Diagram

SM28-4

