

**AT1-5**

Thank you for having chosen an LAE electronic product. Before installing the instrument, please read this instruction booklet carefully in order to ensure safe installation and optimum performance.

**1. INSTALLATION**

**1.1** The AT1-5, size 77x35x77 mm (WxHxD), is inserted into the panel through a hole measuring 71x29 mm and is fixed by means of the suitable clips, by pressing gently. If fitted, check that the rubber gasket adheres to the panel perfectly, in order to prevent debris and moisture infiltration to the back of the instrument.

**1.2** The instrument should work with room temperatures between -10°.. +50°C and relative humidity between 15%.. 80% inclusive. Supply voltage, switched powers and connection set-up should scrupulously comply with the indications given on the container. To reduce the effects of electromagnetic disturbance, keep the sensor and signal cables well separate from the power wires.

**1.3** The sensor T1 measures the air temperature and activates in the thermostat control cycle; it should be placed inside the appliance in a point that truly represents the temperature of the stored product. If fitted and enabled (**T2=YES**), the sensor T2 measures the evaporator temperature and should be placed where there is the maximum formation of frost.

**CAUTION:** should the relays have to switch a heavy load frequently, it is advisable to contact the manufacturer for indications on the lifetime of the contacts.

Whenever products must be kept within very severe specifications or the products have considerable value, the use of a second instrument is recommended, which activates upon or warns of any malfunction.

**2. OPERATING MODES**

Upon switching on, just the central line (autotest) appears on the display for approximately three seconds and the subsequent indications depend on the operating status of the controller. TABLE 1 gives the indications associated with the various states.

STANDBY	NORMAL	INFO MENU	INFO DATA	SETUP MENU	PARAMETER VALUE
OFF Not Operating	-19 Product Temper. (sim.)	T1 Air temperature	→ -20	SCL Display scale	→ 1°C
	DEF Defrost	THI Max. stored temperature	→ 12.5	SPL Minimum setpoint	→ -20
	REC Recovery after defrost	TLO Min. stored temperature	→ -10	SPH Maximum setpoint	→ 40
	HI High temp. alarm	CND Condenser clean cycle	→ 15	---	→ ---
	---	LOC Locked keypad	→ NO	---	→ ---
	E1 Faulty T1 probe			---	→ ---

TABLE 1

**2.1 STANDBY.** If button is pressed for 3 seconds, it allows the AT1-5 to be put on a standby, or to resume output control (with parameter **SB=YES** only). An indication on the display shows that the outputs are off permanently.

**2.2 NORMAL.** During normal operation, the display shows the temperature measured by probe T1, presented in the most appropriate manner. Through parameter **SCL** you select the display range according to the table below:

SCL	1°C (only with INP=SN4)	2°C	°F
RANGE	-50/-9.9.. +19.9/+80	-50.. +120	-55.. +240

The temperature measured by probe T1 may be corrected with a fixed offset by assigning a value other than 0 to the parameter **OS1**. Also probe T2 may be corrected with a fixed offset, in this case parameter **OS2**. Additionally, prior to display, temperature T1 is treated by an

algorithm that allows the simulation of a thermal mass directly proportional to the **SIM** value. The result is a reduction in the fluctuation of the displayed value.

**2.3 INFO MENU.** Pressing the button **[i]** and releasing it immediately activates the information selection menu. From this menu you can display the instantaneous temperatures T1 and T2; the maximum (THI) and minimum (TLO) stored temperature; the total operating time of the condenser since its last cleaning (CND) and the keypad status (LOC). The information to be displayed can be selected sequentially, by pressing **[i]** repeatedly or quickly via the buttons **[v]** and **[a]** to scroll through the menu. Exit from the info menu is by pressing button **[x]** or automatic after 6 seconds of not using the keypad.

In the INFO operating mode it's also possible to reset the recordings THI and TLO and the hour counter CND by pressing buttons **[i]+[x]** simultaneously while the value is displayed.

**2.4 SETPOINT.** The setpoint value is displayed by pressing and keeping button **[i]** pressed for at least half second. The value is programmed by pressing buttons **[i] + [v]** or **[i] + [a]** within the minimum limit **SPL** and the maximum limit **SPH**. When the button is released, the newly programmed value is stored.

**2.5 KEYPAD LOCK.** The keypad lock avoids undesired, potentially dangerous operations, which might be attempted when the controller is operating in a public place. In the INFO mode, through the buttons **[v]** and **[a]** it's possible to assign YES or NO to the parameter **LOC**. With LOC=YES all keypad commands are inhibited. To resume normal operation of keypad, adjust setting so that LOC=NO.

**2.6 DEFROSTING.** By assigning a value greater than 0 to the parameter **DDY**, during defrost the indication **[DEF]** is displayed instead of the temperature. In this case, after defrost and for the time programmed in DDY, the display indication **[REC]** shows that the normal thermostatic cycle is being resumed.

**2.7 ALARM.** An anomaly in the operation is displayed through the lighting up of an abbreviation showing its cause: **[HI]/[LO]** high/low alarm temperature in the cabinet, **[DO]** door open, **[CC]** periodic condenser cleaning, **[E1]/[E2]** fault of probe T1 / T2.

**2.8 SETUP.** The setup is accessed by pressing the buttons **[v]+[i]** in succession and keeping them pressed simultaneously for 5 seconds. The available parameters appear in TABLE 2 as shown below.

### 3. CONFIGURATION

The controller is configured for the system to be controlled by programming the operating parameters, that is, through the setup (see par. 2.8). In SETUP, press button **[a]** to pass from one parameter to the next, and press button **[v]** to go back. To display the value of a parameter press **[i]**, to modify it press buttons **[i] + [v]** or **[i] + [a]** simultaneously. Exit from the setup is by pressing button **[x]** or automatic after 30 seconds of not using the keypad.

Par.	Adjustment	Function	Sect.	Par.	Adjustment	Function	Sect.
SCL	1°C/2°C/°F	Readout scale	2.2	AHA <sup>1)</sup>	-50... +120[°]	Absolute High temperature alarm	6.1
SPL	-50.. SPH [°]	Minimum temperature set point	2.4	ALR <sup>1)</sup>	-120... 0[°]	Low alarm differential	6.1
SPH	SPL.. +120 [°]	Maximum temperature set point	2.4	AHR <sup>1)</sup>	0... 120[°]	High alarm differential	6.1
SP	SPL.. SPH [°]	Effective temperature set point	4.1	ATD <sup>1)</sup>	0.. 120 [min]	Alarm temperature delay	6.1
C-H	REF/HEA	Refrigerating/Heating selection	4.1	ADO	0.. 30 [min]	Door alarm delay	6.2
HYS	+1.. +100 [°]	Thermostat hysteresis	4.1	ACC	0.. 52 [weeks]	Periodic condenser cleaning	6.3
CRT	0.. 30 [min]	Compressor rest time	4.1	SB	YES/NO	Button <b>[v]</b> enabling	2.1
CT1	0.. 30 [min]	Compressor run with sensor T1 failure	4.2	DS	YES/NO	Door switch enabling	6.2
CT2	0.. 30 [min]	Compressor stop with sensor T1 failure	4.2	OAU	NON /0-1/DEF/ LGT/ALR	AUX output control	8.2
CSD	0.. 30 [min]	Compressor stop delay from door opening	4.3	INP	SN4/ST1	NTC/PTC probe selection	8.1
DFR	0.. 24	Defrosting frequency /24h	5.1	OS1	-125.. +125 [°]	Probe T1 offset	2.2
DLI	-50.. +120 [°]	Defrost end temperature	5.3	T2	YES/NO	Probe T2 enabling	1.3
DTO	1.. 120 [min]	Maximum defrosting duration	5.3	OS2	-125.. +125 [°]	Probe T2 offset	2.2
DTY	OFF/ELE/GAS	Defrost type	5.2	TLD	1.. 30 [min]	Delay for min./max. temperature storage	7
DDY	0.. 60 [min]	Defrosting display control	2.6	SIM	0.. 100	Display slowdown	2.2
ATM	NON/ABS/REL	Alarm threshold control	6.1	ADR	1.. 255	Peripheral address	8.3
ALA <sup>1)</sup>	-50... +120[°]	Absolute low temperature alarm	6.1				

TABLE 2

1) Active only with ATM=ABS (ALA, AHA) or with ATM=REL (ALR, AHR).

**\*CAUTION:** upon changing the display scale SCL, it is **ESSENTIAL** to reconfigure the parameters related to the absolute (SPL, SPH, SP, ALA, AHA, etc.) and differential (HYS, ALR, AHR, etc.) temperatures.

### 4. THERMOSTAT CONTROL

**4.1** Thermostat control is based on comparing the temperature T1, the set point **SP** and the hysteresis **HYS**, in the control mode determined by parameter **C-H**. With C-H you choose refrigerating (REF) or heating (HEA) control mode. In order to understand control

modes better, please read the following example:

*C-H=REF: with SP=2.0 and HYS=1.5, the compressor will be Off with T1= +2.0° and On with T1= +3.5° (2+1.5).*

*C-H=HEA: with SP=30 and HYS=4, the heater will be Off with T1= +30° and On with T1=+26° (30-4).*

The output only switches On again if the Off time period determined by **CRT** since the previous switchover has elapsed. Whenever a very small hysteresis HYS must be maintained, it is advised that a suitable value for CRT is selected in order to reduce the number of starts per hour.

**4.2** If sensor T1 fails, the output is controlled by parameters **CT1** and **CT2** giving fixed On and Off times of the output.

*Example: CT1=06, CT2=4, 6 minutes On, 4 minutes Off.*

**4.3** If door switch input control has been enabled (DS=YES), parameter **CSD** determines the delay between when the door is opened and the compressor (heater) stopping.

## 5. DEFROSTING

**5.1** Defrosting starts automatically when necessary time has elapsed to obtain the defrosting frequency set with **DFR**. For example, with DFR=4 defrosting occurs once every 6 hours. The internal timer is set to zero when power is applied to the controller and at each subsequent defrost start. When the controller is put on a standby, the accumulated time count is "frozen" (is not incremented).

Defrosting may also be induced manually by keeping the button  pressed for 2 seconds.

With **C-H=HEA**, all defrost functions are inhibited; differently, with DFR=0, timed defrost only is removed.

**5.2** Once defrost has started, the compressor and defrost outputs are controlled according to parameter **DTY** and **OAU**.

As a matter of fact, please note that the AUX output is configured for defrost control only with OAU=DEF.

<b>DTY</b>	<b>DEFROST</b>	<b>COMPRESSOR</b>
OFF	Off	Off
ELE	On	Off
GAS	On	On

Table 3

**5.3** Defrost lasts for the time **DTO** but, if the evaporator probe has been enabled (T2=YES) and temperature **DLI** is achieved before this time elapses, defrost will be terminated in advance.

## 6. ALARMS



With AT1-5 correct operation of the thermostat may be monitored by a wide range of functional and diagnostics alarms, individually selectable by means of the relevant parameters. The alarm warnings are given on the display through explicit indications (see par. 2.7), with the AUX contacts switching (if the AUX relay is enabled with OAU=ALR), and intermittent buzzer sounding. During an alarm, by pressing any button, the buzzer is muted. Then, if the alarm persists, the buzzer will be periodically switched on for 20 seconds every 60 minutes, until the alarm ends (the display indications remain on all the time). The repeated acoustic warning applies to all alarms with the exception of the condenser cleaning alarm. Operation of the various elements is given in detail below.

**6.1** The parameters **ALx** and **AHx** are the alarm thresholds to determine a correct operation of the application. According to the value given to **ATM**, the thresholds may be ABSOLUTE or RELATIVE. With ATM=ABS, the values programmed for **ALA** and **AHA** will represent the real alarm temperatures. With ATM=REL, **ALR** and **AHR** determine the alarm differentials referred to setpoint and setpoint + hysteresis. In this case, setting one or both differentials to zero cuts out the corresponding alarm. With ATM=NON, all temperature alarms are inhibited.

*Example 1: ATM=ABS, ALA=2.5, AHA=18.0; the thresholds are set at +2.5° and +18°.*

*Example 2: ATM=REL, C-H=REF, SP=20, HYS=2.0, ATL=-5.0, ATH=05.0; the thresholds are set at -25°(-20-5) and -13° (-20+2+5).*

*Example 3: ATM=REL, C-H=HEA, SP=75, HYS=3.0, ATL=-10.0, ATH=7.0; the alarm thresholds are set at +62° (75-3 -10) and +82° (75+7).*

The alarm warning may be immediate or delayed by the time **ATD** whenever this is greater than 0. The indication  for high temperature alarm and  for low temperature alarm blinks on the display. The alarm indication remains stored in the display, even when the alarm is over, until you acknowledge the alarm manually by pressing any button.

The high temperature alarm is bypassed during defrosting.



**6.2** If a suitable door switch has been connected to detect the door status and door switch input control has been enabled (DS=YES), the door open alarm function is enabled. In this way, if the door remains open the controller will react after the time delay set with

**ADO** by displaying the alarm source through the indication .

**6.3** Assigning a value greater than 0 to the parameter **ACC** enables the indication for periodic cleaning of the condenser. Subsequently, when the count of compressor hours of operation reaches the equivalent in weeks set with ACC, an indication for cleaning appears on the display.

*Example: with ACC=16 there is a warning once every  $16 \times 7 \times 24 = 2688$  hours of **compressor operation**, so, assuming for this an operation with 5 minutes On and 5 minutes Off - after approx. 32 weeks.*

In order to clear the time counter, follow the prescribed procedure in paragraph 2.3.

**6.4** Upon failure of probe T1 or, if enabled, probe T2, probe failure is signalled with the blinking indication  or  respectively.

## **7. TEMPERATURE STORAGE**

The AT1-5 features a system for permanent storage of the minimum and maximum temperature logged during operation. This system is a valid help to achieve compliance with the HACCP directive in its part relating to a correct preservation of foodstuffs. Temperature is measured by probe T1 which should therefore be placed in a point where the temperature of the preserved product may always be measured correctly. The logging is however subject to some simple rules that filter the data and give a rational interpretation. The logging is suspended during the periods in which the refrigerator is put on a standby and during defrostings and, during the normal operation (thermostatic control), it's "slowed down" through the parameter **TLD**. This parameter defines the time during which the measured temperature must permanently exceed the current value before the logging is performed. In this way, it will be possible to avoid idle loggings that don't reflect the actual product temperature, for example, the door remaining open for a short period of time, the temperature recovery after a defrost or other temporary short term temperature huntings.

It is suggested that a reasonably long TLD time is programmed, for instance 5-15 minutes, you then put the product into the refrigerator and start a new logging cycle by clearing previous values (see par. 2.3). It will now suffice that at regular intervals, in the INFO menu you check the minimum and maximum logged values in order to know if the product has been kept within the required temperature limits.

## **8. AUXILIARY FUNCTIONS**

**8.1** You select the sensor type for the measurement of temperatures T1 and T2 through the parameter **INP**. With INP=SN4, probes T1 and T2 must be the LAE models NTC SN4.. and with INP=ST1 the probes must be the LAE models PTC ST1.. With INP=ST1 you can only choose the scales with 1° resolution (SCL=2°C or SCL=°F).

**8.2** The operation of auxiliary output is determined by the parameter **OAU**. With OAU=0-1, the relay contacts follow the on/off status of controller (standby=OFF); with OAU=DEF the output is programmed for defrost control (see 5.2). With OAU=LGT the output is enabled to control the lights manually, through the button . Finally, with OAU=ALR, the AUX contacts close when an alarm occurs. With OAU=NON, the AUX output is disabled and the contacts remain constantly opened.

**8.3** The controller is provided with a serial port for connection to a PC or a programmer. In the first case it is important to assign to the parameter **ADR** a different value for each linked unit (peripheral address); with automatic programming, ADR should remain on 1.

## **WARRANTY**

LAE electronic SPA guarantees its products against defects due to faulty materials or workmanship for one (1) year from the date of manufacture shown on the container. The Company shall only replace products which are shown to be defective to the satisfaction of its own technical services. The Company shall not be under any liability and gives no warranty in the event of defects due to exceptional conditions of use, misuse or tampering.

LAE electronic does not accept units back unless LAE electronic has previously given its allowance or request.

**WIRING DIAGRAM**

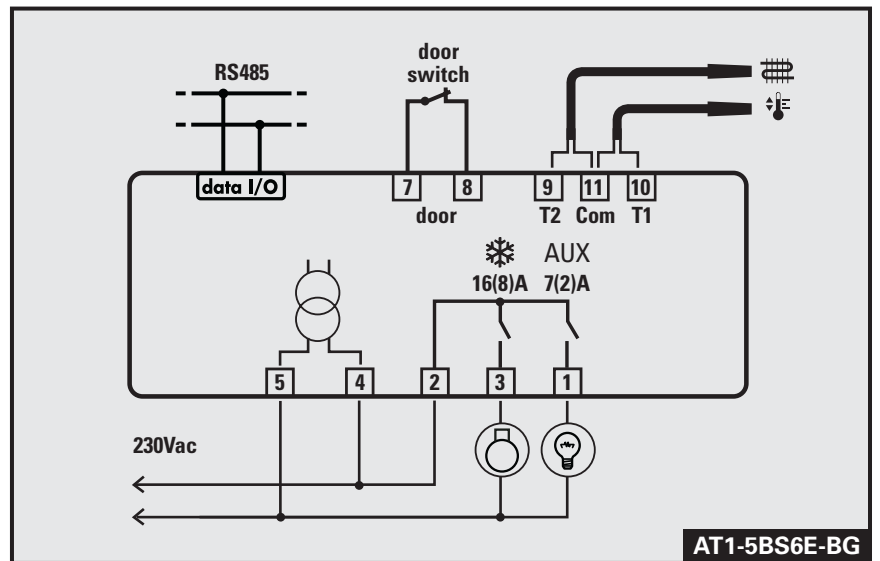
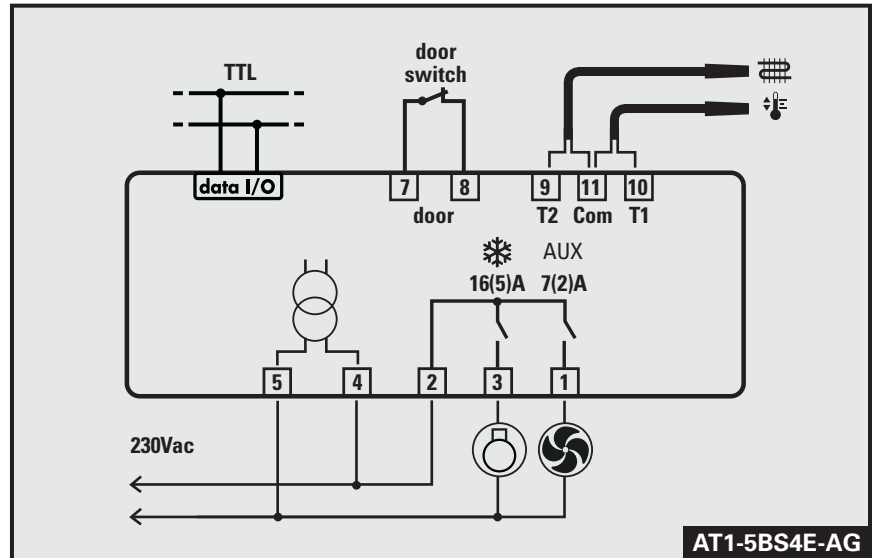

PARTNER VENEZIA • 041 5460713