



### Main Features

- For corrosive gasses and liquids
- Class 1 according to EN 13190
- Capillary 0.5 to 30 m
- Wetted parts and case material stainless steel
- Option : case material 1.4404 (316L) for aggressive atmosphere

### Applications

- Food & Beverage
- Oil & Gas / Chemical
- Laboratory & Medical
- Energy

### Technical Data

Nominal size	63, 80, 100, 160, 250 mm	Window gasket	Elastomer
Temperature ranges	-200 ... 800 °C	Dial	Aluminium, white
Accuracy	Class 1 (according to EN 13190)	Pointer	Aluminium, black
Protection rating	IP 65 (EN 60529)	Accessories	Sliding connections and thermowells, see data-sheets: B51.01 (AGF/AGW) and T6.215 (Ø 8)
Immersion tube	Stainless steel 1.4541 (AISI 321)	Temperature limit	130 % F.S.
Capillary	Stainless steel 1.4541 (AISI 321) max. length 30 m	ATEX	Ex II2GDc (with option 0078)
Bezel ring	Stainless steel 1.4301 (AISI 304)		
Window	Instrument glass		
Movement	Brass		

### Options

Index pointer under window, adjustable knob removable	Code 0053	Oil filling (silicon oil)	Code 0776
Polycarbonat window with max pointer with removable button	Code 0060	Screws secured with loctite	Code 0799
ATEX II2GDc (Only with window laminated safety glass)	Code 0078	Accuracy +/- 0.6 % F.S.	Code 0840
Stainless steel housing 1.4404 (316L) <sup>(1)</sup>	Code 0110	Customer specific immersion length <sup>(3)</sup>	Code 9003_xxxx
Movement stainless steel	Code 0651	Red mark	Code 9700
Process connections (see table on page 4/5)	Code 73xx	Green mark	Code 9701
Laminated safety glass	Code 0751	Stainless steel tag plate and wire	Code 9941
Acrylic window (PMMA or Plexiglass) <sup>(2)</sup>	Code 0752		

<sup>(1)</sup> Only NS 63, NS 100 and NS 160.

<sup>(2)</sup> The case must not be constantly heated over 75 °C.

<sup>(3)</sup> xxxx = L in mm.

## Dimensions in mm

### Type D (Code 11)

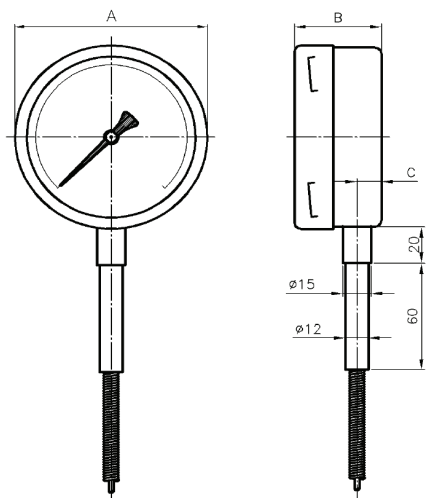

Dimensions	Diameter				
	63	80	100	160	250
A	65	83	101	161	252
B	38	37	45	45	55
C	13	13	13	13	13

### Type C (Code 21)

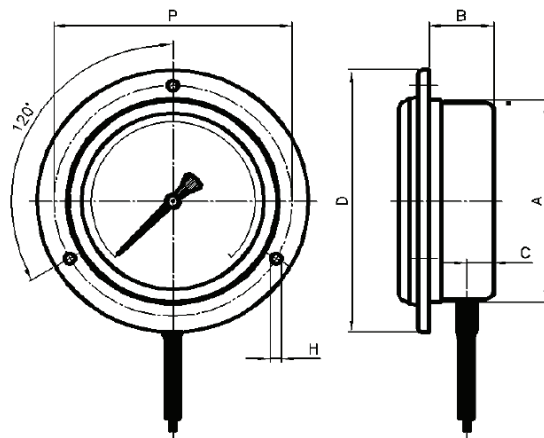

Dimensions	Diameter				
	63	80	100	160	250
A	65	83	101	161	252
B	33	29	31	32	45
C	13	13	13	13	13
D	86	110	132	196	285
H	3.5	4	5.5	6	6
P	75	95	116	178	270

### Type B (Code 22)

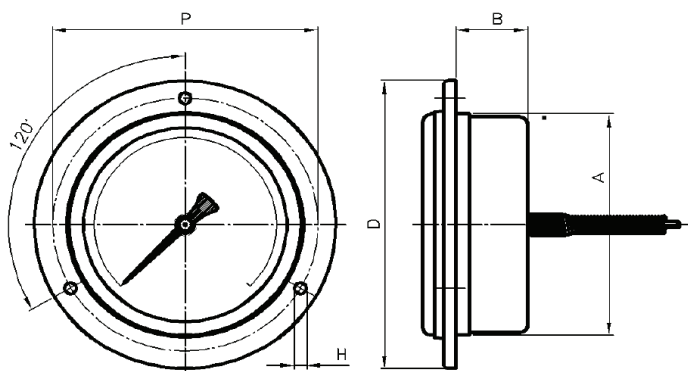

Dimensions	Diameter				
	63	80	100	160	250
A	65	83	101	161	252
B	33	29	31	32	45
D	86	110	132	196	285
H	3.5	4	5.5	6	6
P	75	95	116	178	270

Dimensions	Diameter				
	63	80	100	160	250
A	65	83	101	161	252
B	41	40	51	51	57
C	13	13	13	13	13
D	86	110	132	196	285
H	3.5	4	5.5	6	6
P	75	95	116	178	270

### Type A (Code 31)

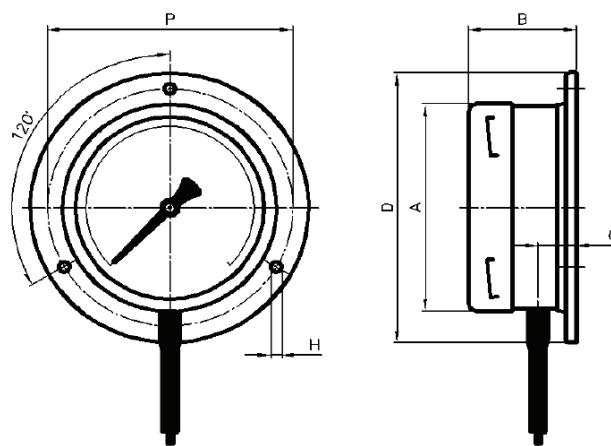

**Dimensions in mm**

**Type E (Code 32)**

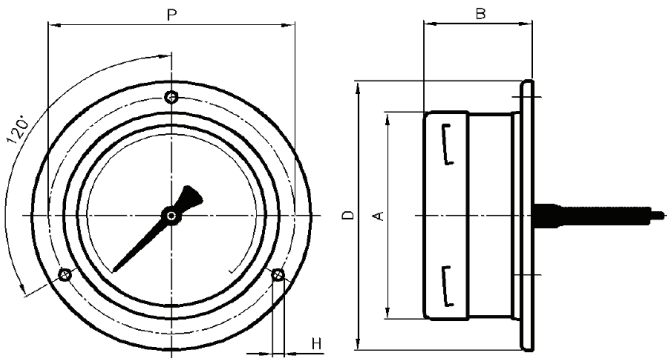

Dimensions	Diameter				
	63	80	100	160	250
A	65	83	101	161	252
B	41	40	51	51	57
D	86	110	132	196	285
H	3.5	4	5.5	6	6
P	75	95	116	178	270

**Type G (Code 53)**

Dimensions	Diameter				
	63	80	100	160	250
A	65	83	101	161	252
B	30	35	35	25	45
C	20	25	20	20	0
D	70	85	112	180	270
E	50	55	60	60	70
P	33	59	75	139	+
T	M5	M5	M5	M5	M5

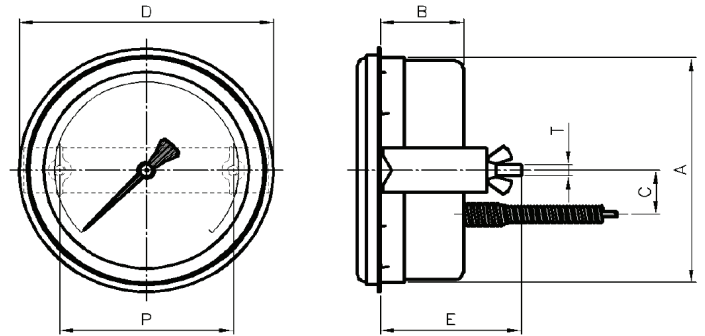

For version 250 mm 3 clamps staggered over 120°

**Type D (Code 61)**

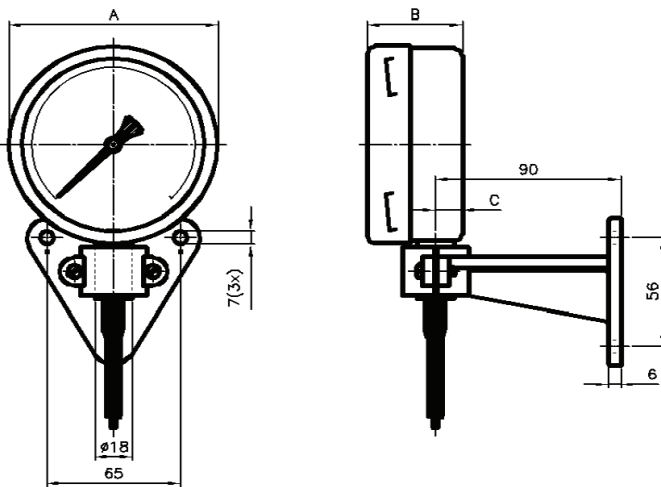

Dimensions	Diameter				
	63	80	100	160	250
A	65	83	101	161	252
B	38	37	45	45	55
C	13	13	13	13	13

## Types of capillary

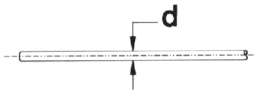
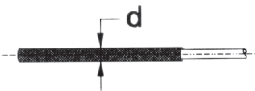
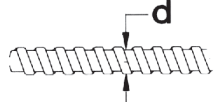
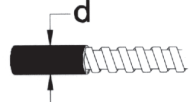
Type	Code	Models	Ø d in mm	Tmin in °C	Tmax in °C
Stainless steel 1.4541 (321) without protection	6		2	- 250	+ 800
Stainless steel 1.4541 (321) with PVC coating	7		4	- 60	+ 120
Stainless steel 1.4541 (321) with stainless steel protection 1.4301 (304)	B		6	- 260	+ 800
Stainless steel 1.4541 (321) with stainless steel protection 1.4301 (304) and PVC coating	C		7.5	- 60	+ 120

## Process connections

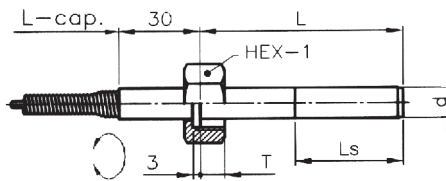
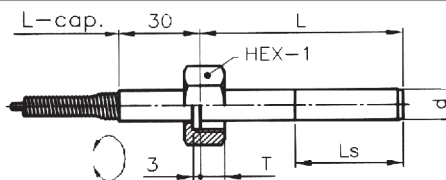
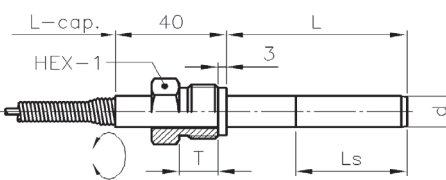
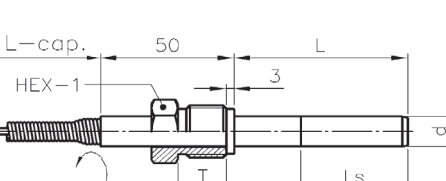
Models	Code	Connection	HEX-1	HEX-2	T	Immersion tube (mm)
 Coupling nut (standard)	731A	G¼	22	-	7	Ø 6 to 8
	731B	G⅜	27	-	9	Ø 6 to 11
	731C	G½	27	-	9	Ø 6 to 15
	731D	G¾	32	-	9	Ø 6 to 20
	731E	G1	41	-	13	Ø 6 to 20
	731P	M18 x 1.5	27	-	8	Ø 6 to 12
	731Q	M20 x 1.5	27	-	9	Ø 6 to 14
	731R	M24 x 1.5	32	-	9	Ø 6 to 18
 Coupling nut (long model)	732C	G½	27	-	14	Ø 6 to 15
	732D	G¾	32	-	16	Ø 6 to 20
	732E	G1	41	-	18	Ø 6 to 20
 Rotating nipple (standard)	733A	G¼	17	-	12	Ø 6 to 8
	733B	G⅜	22	-	12	Ø 6 to 11
	733C	G½	22	-	14	Ø 6 to 15
	733D	G¾	30	-	16	Ø 6 to 20
	733E	G1	36	-	18	Ø 6 to 20
	733P	M18 x 1.5	22	-	12	Ø 6 to 12
	733Q	M20 x 1.5	22	-	14	Ø 6 to 14
	733R	M24 x 1.5	27	-	14	Ø 6 to 18
 Rotating nipple (long model)	734C	G½	22	-	20	Ø 6 to 15
	734D	G¾	30	-	20	Ø 6 to 20
	734E	G1	36	-	25	Ø 6 to 20

## Process connections

Models	Code	Connection	HEX-1	HEX-2	T	Immersion tube (mm)
<p>Coupling nut + double nipple</p>	735A	G $\frac{1}{4}$	27	22	12	Ø 6 to 8
	735B	G $\frac{3}{8}$	27	22	12	Ø 6 to 11
	735C	G $\frac{1}{2}$	27	22	14	Ø 6 to 15
	735D	G $\frac{3}{4}$	27	27	16	Ø 6 to 20
	735E	G1	27	36	18	Ø 6 to 20
	735H	$\frac{1}{4}$ NPT	27	22	14	Ø 6 to 8
	735J	$\frac{1}{2}$ NPT	27	22	20	Ø 6 to 15
	735K	$\frac{3}{4}$ NPT	27	27	20	Ø 6 to 20
	735L	1" NPT	27	36	25	Ø 6 to 20
	735P	M18 x 1.5	27	22	12	Ø 6 to 12
	735Q	M20 x 1.5	27	22	14	Ø 6 to 14
	735R	M24 x 1.5	27	27	14	Ø 6 to 18
<p>Sliding connection on the extension tube</p>	736A	G $\frac{1}{4}$	22	27	12	Ø 6 to 11
	736B	G $\frac{3}{8}$	22	27	12	Ø 6 to 14
	736C	G $\frac{1}{2}$	22	27	14	Ø 6 to 18
	736D	G $\frac{3}{4}$	22	32	16	Ø 6 to 23
	736E	G1	22	36	18	Ø 6 to 30
	736H	$\frac{1}{4}$ NPT	22	27	14	Ø 6 to 13
	736J	$\frac{1}{2}$ NPT	22	27	20	Ø 6 to 20
	736K	$\frac{3}{4}$ NPT	22	27	20	Ø 6 to 25
	736L	1" NPT	22	36	25	Ø 6 to 32
	736P	M18 x 1.5	22	27	12	Ø 6 to 16
	736Q	M20 x 1.5	22	27	14	Ø 6 to 18
	736R	M24 x 1.5	22	27	14	Ø 6 to 22
<p>Sliding connection on the capillary</p>	737A	G $\frac{1}{4}$	22	27	12	Ø 6 to 11
	737B	G $\frac{3}{8}$	22	27	12	Ø 6 to 14
	737C	G $\frac{1}{2}$	22	27	14	Ø 6 to 18
	737D	G $\frac{3}{4}$	22	32	16	Ø 6 to 23
	737E	G1	22	36	18	Ø 6 to 30
	737H	$\frac{1}{4}$ NPT	22	27	14	Ø 6 to 13
	737J	$\frac{1}{2}$ NPT	22	27	20	Ø 6 to 20
	737K	$\frac{3}{4}$ NPT	22	27	20	Ø 6 to 25
	737L	1" NPT	22	36	25	Ø 6 to 32
	737P	M18 x 1.5	22	27	12	Ø 6 to 16
	737Q	M20 x 1.5	22	27	14	Ø 6 to 18
	737R	M24 x 1.5	22	27	14	Ø 6 to 22
<p>Sliding connection on the stem</p>	738A	G $\frac{1}{4}$	22	27	12	Ø 6 to 8
	738B	G $\frac{3}{8}$	22	27	12	Ø 6 to 11
	738C	G $\frac{1}{2}$	22	27	14	Ø 6 to 15
	738D	G $\frac{3}{4}$	22	32	16	Ø 6 to 20
	738E	G1	22	36	18	Ø 6 to 20
	738H	$\frac{1}{4}$ NPT	22	27	14	Ø 6 to 8
	738J	$\frac{1}{2}$ NPT	22	27	20	Ø 6 to 15
	738K	$\frac{3}{4}$ NPT	22	27	20	Ø 6 to 20
	738L	1" NPT	22	36	25	Ø 6 to 20
	738P	M18 x 1.5	22	27	12	Ø 6 to 12
	738Q	M20 x 1.5	22	27	14	Ø 6 to 14
	738R	M24 x 1.5	22	27	14	Ø 6 to 18

Note: minimum immersion length: see table on page 6

## Temperature ranges

Code	Range °C
69T	-200 ... 50
77T	-120 ... 40
76T	-100 ... 50
74T	-80 ... 40
68T	-70 ... 50
50T	-60 ... 40
65T	-40 ... 40
55T	-30 ... 170
51T	-30 ... 70
61T	-30 ... 30
84T	-20 ... 100
54T	-20 ... 60
52T	-20 ... 40
11T	0 ... 60
27T	0 ... 80

Code	Range °C
12T	0 ... 100
20T	0 ... 120
13T	0 ... 160
22T	0 ... 200
14T	0 ... 250
23T	0 ... 300
15T	0 ... 400
25T	0 ... 500
16T	0 ... 600
82T	0 ... 800
30T	100 ... 500

Code	Range °F
68U	-100 ... 120
09U	-50 ... 120
08U	-40 ... 160
02U	0 ... 200
03U	0 ... 250
04U	0 ... 300
05U	0 ... 400
06U	0 ... 500
20U	30 ... 250
13U	30 ... 320
22U	30 ... 400
23U	30 ... 580
15U	30 ... 750
28U	100 ... 800
29U	200 ... 1000

Code	Range (double scale)			
	°C		/	°F
51V	-30 ... 70	/	-40 ... 160	
68V	-70 ... 50	/	-100 ... 100	
55V	-30 ... 170	/	0 ... 350	
11V	0 ... 60	/	30 ... 140	
20V	0 ... 120	/	30 ... 250	
13V	0 ... 160	/	30 ... 320	
14V	0 ... 250	/	30 ... 500	
15V	0 ... 400	/	30 ... 750	
16V	0 ... 600	/	100 ... 1100	

## Minimum immersion length Ls (mm)

Diameter of the Immersion tube (mm)							
Ø 6	Ø 8	Ø 9	Ø 10	Ø 11	Ø 12	Ø 14	Ø 16
70	35	30	25	20	18	15	13
120	60	45	35	30	25	20	17
190	90	60	55	45	35	30	25
-	135	100	80	65	55	40	30
-	170	130	100	80	65	50	40
-	-	190	150	120	95	70	55
Length of sensitive part Ls (mm)							

Capillary length (m)				
≤ 2	≤ 5	≤ 10	≤ 20	≤ 30
80	100	120	n.a.	n.a.
60	80	80	100	120
-	-	-	80	100
-	-	-	-	-
-	-	60	-	-
-	-	-	60	60
Min. temperature span (°C)				

### How to use this table:

1. Select in the right table the first column, which covers your capillary length.
2. Move down in this column to the first value, which is not higher than your temperature span.
3. Move horizontal to the left table into the column with your selected immersion tube diameter.
4. Read the minimum length of the sensitive part of the immersion tube for your selection.

If this is too long, choose a larger diameter, a larger range or a shorter capillary.

### Example:

4 m capillary, -20 ... 40 °C (span = 60 °C),  
Immersion tube Ø 10 mm:  
Minimum length of the sensitive part: Ls ≥ 80 mm

Standard version with plain immersion tube (without process connection)

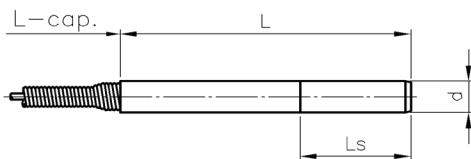

## Ordering example with options

	TSF	100	-	2	61	.	1	B	0	.	20T	.	30	/	738C	-	9003	-	0210
Gas filled thermometer with capillary	TSF	100	-	2	61	.	1	B	0	.	20T	.	30	/	738C	-	9003	-	0210
Nominal size 100 mm		100																	
Case material stainless steel 1.4301 (AISI 304)			-																
Support console for wall mounting, capillary outlet bottom				2															
Immersion tube diameter 8 mm					61														
Type of capillary stainless steel 1.4541 with stainless steel protection 1.4301 Ø 6 mm (up to 800 °C)						.	1												
Immersion length (L) customer specific																			
Temperature range: 0 ... 120 °C											20T								
Length of capillary: 3 m																			
Option: Adjustable connection sliding on stem G½																			
Option: Customer specific immersion length																			
Option: Customer specific immersion length L = 210 mm																			

## Ordering details TSF

	TSF			-	2	xx	.			.	xxx	.	xx	/
<b>Model</b>	TSF													
Gas filled thermometer with capillary	TSF													
<b>Nominal size</b>														
63 mm						0	6	3						
80 mm						0	8	0						
100 mm						1	0	0						
160 mm						1	6	0						
250 mm						2	5	0						
<b>Case</b>														
Stainless steel 1.4301 (AISI 304)													2	
<b>Type of mounting</b>														
Direct mounting, capillary outlet bottom														11
Front flange for panel mounting, capillary outlet bottom														21
Front flange for panel mounting, capillary outlet center back														22
Rear flange for wall mounting, capillary outlet bottom														31
Rear flange for wall mounting, capillary outlet center back														32
U-clamp for panel mounting, capillary outlet lower back														53
Support console for wall mounting, capillary outlet bottom														61
<b>Immersion tube diameter</b>														
6 mm														4
8 mm														1
9 mm														A
10 mm														B
11 mm														2
12 mm														C
14 mm														7
16 mm														D
<b>Type of capillary</b>														
Stainless steel 1.4541 without protection, Ø 2.0 mm (up to 800 °C)														6
Stainless steel 1.4541 with PVC, Ø 4.0 mm (up to 120 °C)														7
Stainless steel 1.4541 with stainless steel protection 1.4301, Ø 6.0 mm (up to 800 °C)														B
Stainless steel 1.4541 with stainless steel protection 1.4301 + PVC, Ø 7.5 mm (up to 120 °C)														C
<b>Immersion tube / installed length L</b>														
100 mm														2
160 mm														4
250 mm														6
400 mm														7
600 mm														8
1000 mm														9
Customer specific length (use option 9003_xxxx, xxxx = L in mm)														0
<b>Unit of measurement / Temperature ranges</b>														
°C														xxT
°F														xxU
°C / °F (double scale)														xxV
<b>Length of capillary</b>														
0.5 m														05
1 m														10
3 m														30
4.5 m														45
6 m														60
9 m														90
12 m														A2
15 m														A5
20 m														B0
25 m														B5
30 m														C0
<b>Options to be added behind the / (see example page 6)</b>														/